



TH	THAILAND
----	----------

Diagram / Parts List

9910

BELT SANDER 76MM



(TH) 9910 / BELT SANDER 76MM

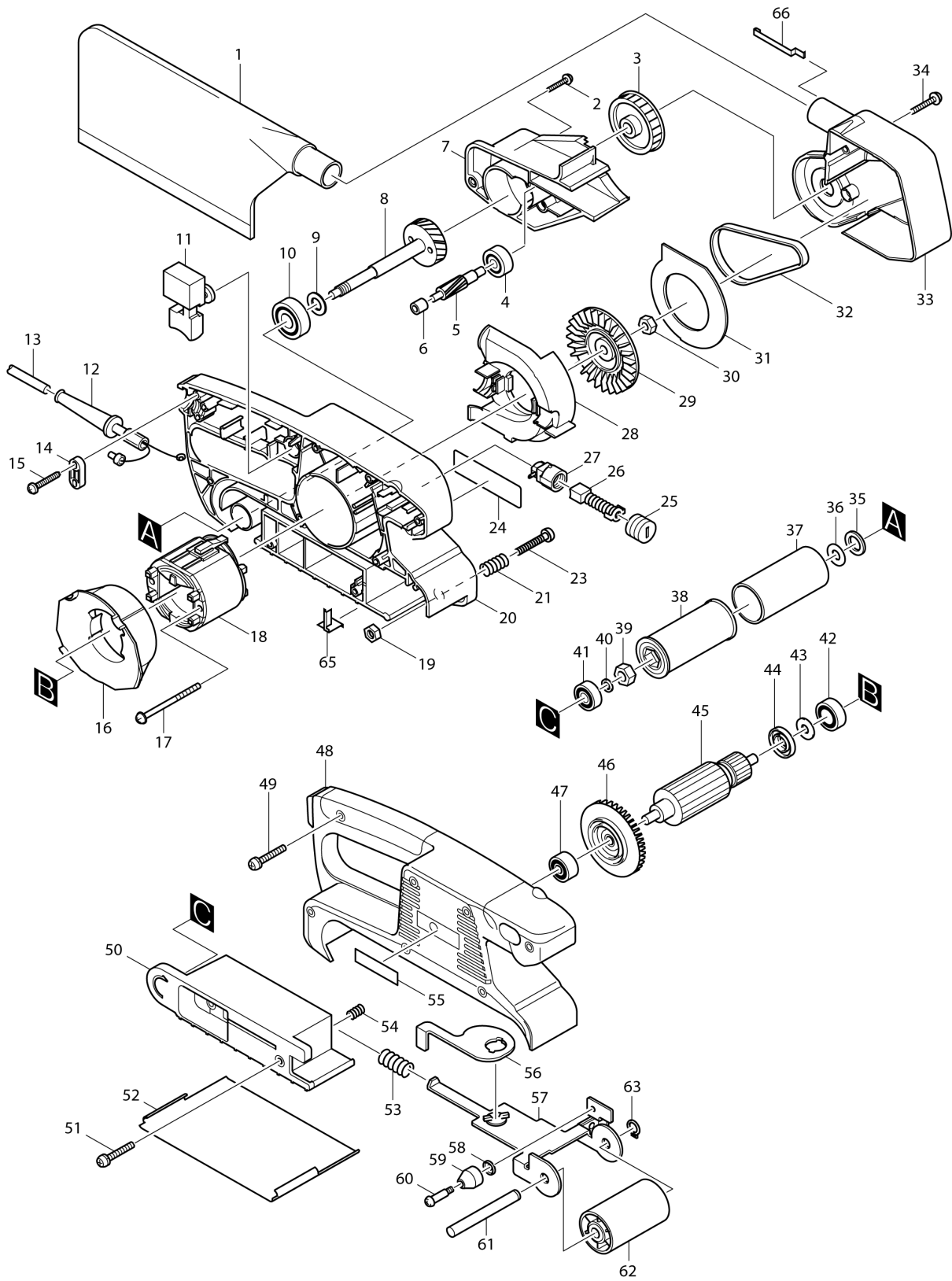

TH	THAILAND
----	----------

9910 / BELT SANDER 76MM

Item	Sub	Parts No.	Parts Description	Qty	I/C	E/C No.	Close No.	Remark
001		122548-3	DUST BAG ASS'Y	1				
	C10	410602-8	FASTENER	1		92776		
002		265999-8	TAPPING SCREW 4X25	4				
003		222144-8	PULLEY 8.5-45.1	1				
004		210005-4	BALL BEARING 608DDW	1				
005		226494-3	HELICAL GEAR 6	1				
006		212009-2	NEEDLE BEARING 509	1				
007		416420-2	BRACKET	1				
008		153252-3	HELICAL GEAR 31 COMPLETE	1				
009		253758-2	FLAT WASHER 10	1				
010		211088-7	BALL BEARING 6000DDW	1				
011		651285-7	SWITCH SGEL206C-4	1			DB412	
011-1		651285-7	SWITCH SGEL206C-4	1	O	DB412		
012		682504-0	CORD GUARD 10-85	1			DU529	
012-1		682502-4	CORD GUARD 8-85	1	S	DU529		
013H		691015-4	POWER SUPPLY CORD 0.75-2-2.5	1			DU529	
013H1		660503-2	POWER SUPPLY CORD 0.75-2-2.5	1	S	DU529		
014		687053-2	STRAIN RELIEF	1			DU529	
014-1		687052-4	STRAIN RELIEF	1	S	DU529		
015		265995-6	TAPPING SCREW 4X18	2				
016		416418-9	BAFFLE PLATE	1				
017		266052-3	TAPPING SCREW 4X60	2				
018B		633393-6	FIELD 220-240V	1				220V/240V
019		931202-6	HEX. NUT M5	1				
020		150958-4	HOUSING L COMPLETE	1				
	D10		INC. 6,19					
021		233219-8	COMPRESSION SPRING 6	1				
023		911252-7	PAN HEAD SCREW M5X30	1				
024		859229-3	NAME PLATE 9910	1			Z36496	
024-1		859594-0	NAME PLATE 9910	1	<	Z36496		
025		643550-8	BRUSH HOLDER CAP 5-8	2				
026A		191940-4	CARBON BRUSH CB-411	1			85070	
026A1		B-80391	CARBON BRUSH SET CB-411A	1	<	85070		
027		643922-7	BRUSH HOLDER	2				
028		416416-3	SCROLL PLATE	1				
029		241660-1	FAN 68	1				
030		252153-3	HEX. NUT M6-10	1				
031		344584-1	PLATE	1				
032		225079-2	SYNCHRO BELT 6-300	1				
033		416415-5	BELT COVER	1				
034		265999-8	TAPPING SCREW 4X25	4				
035		267177-6	FLAT WASHER 12	1				
036		253865-1	FLAT WASHER 8	1				
037		422032-1	RUBBER SLEEVE 29	1				
038		316971-4	DRIVING ROLLER	1				
039		252154-1	HEX. NUT M8-13	1				
040		253077-6	FLAT WASHER 6	1				
041		210022-4	BALL BEARING 626DDW	1				
042		210023-2	BALL BEARING 627DDW	1				
043		253823-7	FLAT WASHER 7	1				
044		681648-3	INSULATION WASHER	1				
044-1		681658-0	INSULATION WASHER	1	X	60612		
045B		517243-2	ARMATURE ASS'Y 220-240V	1				220V/240V
	D10		INC. 42-44,46,47					
046		240008-4	FAN 60	1				
047		211021-9	BALL BEARING 607LLB	1				
048		182981-1	HOUSING R	1				
	D10		INC. 55					
049		265999-8	TAPPING SCREW 4X25	7				
050		416419-7	SHOE	1				
051		265999-8	TAPPING SCREW 4X25	2				
052		344586-7	STEEL PLATE	1			71074	
052-1		345503-0	STEEL PLATE	1	O	71074		
053		233221-1	COMPRESSION SPRING 12	1				
054-1		231038-6	COMPRESSION SPRING 6	1				

A:

Interchange
O : Yes
X : No
< : the new part can be substituted for the current.
> : the current part can be substituted for the new.
S : Interchangeable as a set.

