



2025 PRODUCT



Screwing/
Drilling 25

Stirring 52

Hammer
drilling/
Chiselling 55

Grinding/
Sanding/
Polishing 74

Cutting 102

Sawing 111

Milling/
Planing 127

Fastening/
Fixing 134

Cleaning 139

Lawn care/
Grass care 152

Tree care/
Hedge care 167

Transportation 177

Measuring/
Leveling 179

Lights 183

Comfort/
Lifestyle 189

Speciality tools 198

Accessory 202

DGA452	78	DJS161	107	DPP200	107	DUA200	171	DVC265	143
DGA454	77	DJS200	107	DPT353	136	DUA250	171	DVC350	143
DGA455	78	DJS800	108	DPV300	93	DUA251	171	DVC560	145
DGA456	77	DJV180	123	DRC200	145	DUA300	171	DVC660	143
DGA458	78	DJV181	123	DRC300	145	DUA301	171	DVC665	143
DGA463	77	DJV182	123	DRS780	118	DUB184	149	DVC750L	143
DGA467	78	DJV184	123	DRT50	128	DUB185	149	DVC860L	141
DGA469	78	DJV185	123	DRT52	128	DUB186	149	DVC861L	141
DGA504	77	DKP180	131	DRV150	135	DUB187	149	DVC865L	141
DGA505	78	DKP181	131	DRV250	135	DUB361	149	DVC866L	141
DGA506	77	DKT360	197	DS4011	34	DUB362	149	DVC867L	141
DGA508	78	DLM330	156	DS4012	34	DUB363	149	DVP180	199
DGA511	77	DLM382	156	DS5000	34	DUC101	170	DVP181	199
DGA512	77	DLM432	156	DSC102	106	DUC122	169	DVR350	53
DGA513	77	DLM460	156	DSC121	106	DUC150	170	DVR450	53
DGA514	77	DLM462	156	DSC163	106	DUC204	169	DVR850	53
DGA517	78	DLM463	156	DSC191	106	DUC254	169	DWR180	42
DGA518	78	DLM465	156	DSC251	105	DUC254C	169	DWT310	42
DGA519	78	DLM480	155	DSD180	126	DUC256	169	DX08	57
DGA520	78	DLM481	155	DSL801	99	DUC256C	169	DX09	57
DGA521	77	DLM530	155	DSP600	122	DUC303	169	DX10	56
DGA700	77	DLM532	155	DSP601	122	DUC305	169	DX11	56
DGA701	77	DLM533	155	DSS501	118	DUC306	169	DX12	57
DGA900	77	DLM534	155	DSS610	117	DUC307	169	DX14	57
DGA901	77	DLM536	155	DSS611	117	DUC353	169	DX15	56
DGD800	94	DLM537	155	DST112	136	DUC355	169	DX16	57
DGD801	94	DLM538	155	DST221	136	DUC356	169		
DGP180	199	DLM539	155	DTC100	109	DUC357	169	EE400MP	164
DHG180	201	DLS110	112	DTC101	109	DUC400	169	EJ400MP	164
DHG181	201	DLS111	112	DTC102	109	DUC405	169	ELM3320	157
DHK180	70	DLS112	112	DTC103	109	DUC406	169	ELM3720	157
DHP451	28	DLS211	112	DTD043	50	DUC407	169	ELM4120	157
DHP453	29	DLS212	112	DTD063	50	DUH501	172	ELM4121	156
DHP458	28	DLS600	113	DTD064	50	DUH502	172	ELM4620	156
DHP482	28	DLS713	112	DTD103	50	DUH506	172	ELM4621	156
DHP484	27	DLS714	112	DTD104	50	DUH507	173	EM402MP	164
DHP485	28	DLW140	105	DTD152	32	DUH601	172	EM403MP	164
DHP486	27	DMLC300	106	DTD153	32	DUH602	172	EM404MP	164
DHP487	28	DML185	187	DTD154	32	DUH604S	173	EM405MP	164
DHP489	27	DML800	188	DTD156	32	DUH606	172	EM406MP	164
DHR165	58	DML801	188	DTD157	32	DUH607	173	EM407MP	164
DHR171	58	DML802	187	DTD173	32	DUH751	172	EM408MP	164
DHR182	58	DML803	188	DTDA040	50	DUH752	172	EM409MP	164
DHR183	58	DML805	186	DTDA070	50	DUH754S	173	EN401MP	164
DHR202	58	DML806	187	DTDA100	50	DUM111	166	EN402MP	164
DHR241	58	DML807	187	DTDA140	50	DUM604	166	EN410MP	164
DHR242	58	DML808	187	DTL061	33	DUN461W	175	EN420MP	164
DHR243	58	DML809	186	DTL063	42	DUN500W	175	EN421MP	164
DHR263	58	DML811	186	DTM50	110	DUN501W	175	EN422MP	164
DHR264	58	DML812	186	DTM51	110	DUN600L	175	EN424MP	164
DHR280	57	DML814	186	DTM52	110	DUN601L	175	EY402MP	164
DHR281	57	DML816	187	DTP141	34	DUP180	176	EY403MP	164
DHR282	57	DML817	188	DTR180	135	DUP361	176		
DHR283	57	DML818	186	DTR181	135	DUP362	176	FN001G	135
DHR400	57	DMP180	196	DTS141	34	DUR189	161	FS2200	45
DHS630	117	DMP181	196	DTW073	51	DUR190L	160	FS2300	45
DHS660	117	DMR055	191	DTW074	51	DUR190U	160	FS2500	44
DHS661	117	DMR056	191	DTW1001	39	DUR191L	161	FS2700	44
DHS680	117	DMR057	191	DTW1002	39	DUR191U	161	FS2701	44
DHS710	117	DMR203	191	DTW1004	39	DUR192L	161	FS4000	45
DHS780	117	DMR300	190	DTW103	51	DUR193	161	FS4200	45
DHS781	117	DMR301	190	DTW104	51	DUR194	161	FS4300	45
DHS782	117	DP2010	35	DTW180	40	DUR368A	160	FS6200	45
DHS783	116	DP2011	35	DTW181	40	DUR368L	160	FS6300	45
DHS900	116	DP4000	35	DTW190	40	DUR369A	160	FS6300R	45
DHS901	116	DP4001	35	DTW251	40	DUR369L	160		
DHW080	150	DP4002	35	DTW253	40	DUR369N	160	GA003G	75
DHW180	151	DP4003	34	DTW300	40	DUS054	176	GA004G	75
DJN161	108	DP4010	34	DTW301	40	DUS108	176	GA005G	75
DJR183	125	DP4011	34	DTW302	40	DUS158	176	GA006G	75
DJR185	126	DP4020	35	DTW450	40	DUT130	54	GA007G	75
DJR186	125	DP4021	35	DTW700	40	DUT131	54	GA008G	75
DJR187	125	DPB180	106	DTW701	40	DUV320	157	GA011G	75
DJR188	125	DPB182	107	DTW800	39	DUX18	163	GA012G	75
DJR189	125	DPB183	106	DTWA070	51	DUX60	163	GA013G	75
DJR360	125	DPB184	107	DTWA100	51	DVC155L	140	GA014G	75
DJS101	108	DPJ180	131	DTWA140	51	DVC156L	140	GA015G	75
DJS130	107	DPO500	95	DTWA190	51	DVC157L	140	GA016G	75
DJS131	107	DPO600	95	DTWA260	51	DVC261	143	GA021G	75

Index

G		G		G		H		J	
GA022G	75	GA5080R	82	GV6010	92	HR2320T	62	JR3070CT	126
GA023G	75	GA5090	78	GV7000	92	HR2475	62	JS1000	108
GA024G	75	GA5091	79	GV7000C	92	HR2600	62	JS1601	108
GA025G	75	GA5092	79	H		HR2601	62	JS1602	108
GA026G	75	GA5093	79	HB350	37	HR2631F	62	JS3201	108
GA027G	75	GA5094	79	HB500	37	HR2631FT	61	JS8000	108
GA028G	75	GA5095	79	HG5030	201	HR2641	61	JV001G	123
GA029G	75	GA6010	82	HG6030	201	HR2652	62	JV002G	123
GA030G	76	GA6020	82	HG6031V	201	HR2653	62	JV0600	124
GA031G	76	GA6020C	79	HG6530V	201	HR2653T	62	JV101D	123
GA032G	76	GA6021	82	HG6531C	201	HR2663	62	JV102D	123
GA035G	76	GA6021C	79	HK0500	70	HR2670	61	JV103D	123
GA036G	76	GA6040	82	HK1810	71	HR2670FT	61	JV183D	124
GA037G	76	GA6040C	80	HK1820	70	HR2800	61	K	
GA038G	76	GA6040R	82	HM001G	68	HR2810	61	KP001G	131
GA039G	76	GA6042C	80	HM002G	68	HR2810T	61	KP0800	132
GA040G	76	GA7010C	88	HM004G	69	HR2811F	61	KP0810	131
GA041G	76	GA7012C	88	HM0810	69	HR2811FT	61	KP0810C	131
GA042G	76	GA7020	87	HM0810B	69	HR3001C	61	KP312	132
GA043G	76	GA7020R	87	HM0810T	69	HR3011FC	60	KP312S	132
GA044G	76	GA7020S	87	HM0830	69	HR3012FC	60	KR400MP	164
GA045G	76	GA7030	86	HM0870C	69	HR3200C	60	KR401MP	164
GA046G	76	GA7030R	86	HM0871C	69	HR3210C	60	KT001G	197
GA047G	76	GA7031	86	HM1101C	68	HR3210FCT	60	L	
GA048G	76	GA7040S	85	HM1111C	68	HR3530	60	LB1200F	122
GA049G	76	GA7050	88	HM1201	68	HR3540C	60	LC1230	104
GA050G	76	GA7050R	87	HM1203C	68	HR3541FC	60	LD030P	182
GA051G	76	GA7060	87	HM1205C	68	HR4002	60	LD050P	182
GA4030	84	GA7060R	87	HM1213C	68	HR4003C	59	LD080P	182
GA4030R	83	GA7061	86	HM1214C	68	HR4013C	60	LD080PI	182
GA4031	83	GA7061R	86	HM1306	68	HR4030C	59	LE400MP	164
GA4032	83	GA7064	87	HM1307C	70	HR4041C	59	LF1000	115
GA4034	84	GA7070	85	HM1307CB	70	HR4501C	59	LH1040	115
GA4040	82	GA7071	85	HM1317C	70	HR4510C	59	LH1040F	115
GA4040C	80	GA7080	85	HM1317CB	70	HR4511C	59	LH1201FL	115
GA4050	81	GA7081	85	HM1501	70	HR5202C	59	LM001C	154
GA4050R	81	GA7082	85	HM1502	70	HR5212C	59	LM001G	155
GA4051R	81	GA7090	87	HM1511	69	HS003G	116	LM001J	154
GA4530	84	GA9010C	88	HM1512	70	HS004G	116	LM002G	155
GA4530R	83	GA9012C	88	HM1802	69	HS009G	116	LM002J	154
GA4534	84	GA9020	87	HM1812	69	HS010G	116	LM003G	155
GA4540	82	GA9020R	87	HP001G	27	HS011G	116	LM003J	154
GA4540C	80	GA9020S	87	HP002G	27	HS012G	116	LM004G	155
GA4540R	82	GA9030	86	HP0300	30	HS013G	116	LM004J	154
GA4542C	80	GA9030R	86	HP1230	72	HS0600	121	LS002G	112
GA4550	81	GA9030S	86	HP1630	72	HS300D	118	LS003G	112
GA4550R	81	GA9031	86	HP1631	71	HS301D	118	LS004G	112
GA4551R	81	GA9040R	85	HP1640	72	HS6100	118	LS0714	114
GA4552	81	GA9040S	85	HP1641	72	HS6101	118	LS0714F	114
GA4552R	81	GA9050	88	HP1641F	72	HS6600	119	LS0714FL	114
GA4553R	81	GA9050R	87	HP2050	71	HS6601	118	LS0714L	114
GA4570	83	GA9060	87	HP2050F	71	HS7000	120	LS0815F	113
GA4590	78	GA9060R	87	HP2051	71	HS7010	119	LS0815FL	113
GA4591	79	GA9061	86	HP2051F	71	HS7100	120	LS0816F	114
GA4592	79	GA9061R	86	HP2070	71	HS7101	120	LS1017L	113
GA4593	79	GA9062	86	HP2070F	71	HS7600	120	LS1018L	113
GA4594	79	GA9070	85	HP2071	71	HS7601	120	LS1019	113
GA4595	79	GA9071	85	HP2071F	71	HS7610	119	LS1019L	113
GA5010	82	GA9080	85	HP330D	30	HS7611	119	LS1030N	115
GA5011	82	GA9081	85	HP332D	29	HW001G	150	LS1040	114
GA5020	82	GA9082	85	HP333D	29	HW101	151	LS1040F	114
GA5020C	79	GA9090	87	HP347D	30	HW102	151	LS1045	114
GA5021	82	GB602	95	HP488D	30	HW111	151	LS1110F	113
GA5021C	79	GB602W	95	HR001G	56	HW112	151	LS1219	113
GA5030	84	GB801	95	HR002G	56	HW1200	151	LS1219L	113
GA5030R	83	GD0600	94	HR003G	57	HW121	151	LS1221	114
GA5034	84	GD0601	94	HR004G	56	HW1300	151	LS1440	114
GA5040	82	GD0602	94	HR005G	56	HW140	150	LW1400	105
GA5040C	80	GD0603	95	HR006G	56	HW151	150	LW1401	105
GA5040R	82	GD0800	94	HR007G	56	J		M	
GA5041C	80	GD0800C	94	HR008G	56	JN1601	108	ML001G	187
GA5042C	80	GD0801C	94	HR009G	56	JN3201	108	ML002G	187
GA5050	81	GD0810C	94	HR010G	57	JR001G	125	ML003G	186
GA5050R	81	GD0811C	94	HR140D	59	JR002G	125	ML005G	186
GA5051R	81	GF600	135	HR166D	59	JR1000FT	126	ML006G	187
GA5052	81	GN420C	138	HR1840	63	JR103D	126	ML007G	186
GA5052R	81	GS5000	95	HR1841F	63	JR105D	126	ML009G	186
GA5053R	81	GS6000	95	HR2230	63	JR3051T	126	ML010G	186
GA5080	82	GV5010	92	HR2300	63	JR3061T	126	ML011G	188

M		S		U		U	
ML012G	186	SA5040C	92	UC002G	168	UR2300	162
ML102	188	SA7000	92	UC003G	168	UR3000	162
ML104	187	SA7000C	92	UC004G	168	UR3500	162
ML107	188	SC103D	106	UC005G	168	UR3501	162
MLT100N	115	SD100D	126	UC006G	168	UR3502	162
MP001G	196	SG1251	105	UC007G	168	US053D	176
MP100D	196	SJ401	126	UC010G	168	UT001G	54
MR001G	190	SK105D	181	UC011G	168	UT002G	54
MR002G	190	SK105GD	181	UC012G	168	UT1200	54
MR003G	190	SK106D	180	UC013G	168	UT1305	54
MR004G	190	SK106GD	180	UC014G	168	UT1400	54
MR006G	190	SK10GD	180	UC015G	168	UT1401	54
MR007G	190	SK209GD	180	UC016G	168	UT1600	54
MR009G	191	SK20GD	180	UC017G	168	UT2204	54
MR010G	191	SK312GD	180	UC020G	168	UV001G	157
MR014G	191	SK40GD	180	UC021G	168	UV3200	157
MR051	190	SK700D	180	UC022G	168	UV3600	157
MR052	190	SK700GD	180	UC023G	168	UX01G	163
MW001G	197	SKR001	181	UC024G	168	V	
N		SKR200Z	181	UC025G	168	VC001GL	140
N3701	128	SN400MP	164	UC026G	168	VC002GL	140
N5900B	121	SP001G	122	UC029G	170	VC003GL	140
N9500N	84	SP6000	122	UC100D	170	VC004GL	140
P		ST113D	136	UC3041A	170	VC005GL	140
PB002G	106	SW400MP	164	UC3050A	170	VC006GM	140
PC5000C	132	T		UC3051A	170	VC007GL	140
PC5001C	132	TD001G	32	UC3541A	170	VC008G	143
PC5010C	132	TD002G	32	UC3550A	170	VC009G	143
PDC01	24	TD003G	32	UC3551A	170	VC010G	145
PDC1200	24	TD004G	32	UC4041A	170	VC011G	143
PDC1500	24	TD0100	33	UC4050A	170	VC012G	143
PF0300	200	TD0101	33	UC4051A	170	VC1310L	142
PF0403	200	TD0101F	33	UC4550A	170	VC2000L	142
PF0410	200	TD022D	33	UC4551A	170	VC2012L	142
PF0610	200	TD090D	33	UD2500	157	VC2201M	141
PF0800	200	TD091D	51	UE001G	162	VC2211M	141
PF1010	200	TD110D	33	UH004G	172	VC2510L	142
PF1100	200	TD111D	33	UH005G	172	VC2512L	142
PF1110	200	TD112D	50	UH006G	172	VC3011L	142
PF400MP	164	TD127D	33	UH007G	172	VC3012L	142
PJ7000	131	TL064D	34	UH008G	172	VC3012M	142
PK5011C	92	TL065D	42	UH009G	172	VC3210L	141
PM001G	176	TM001G	110	UH013G	173	VC3211H	141
PO5000C	95	TM3000C	110	UH014G	173	VC3211M	141
PO6000C	95	TM3010C	110	UH020G	172	VC4210L	142
PP001G	107	TM30D	110	UH021G	172	VC4210M	142
PS001G	151	TW001G	39	UH200D	173	VR001C	53
PT001G	136	TW002G	39	UH201D	173	VR001G	53
PT354D	136	TW003G	39	UH4261	174	VR002C	53
PV001G	92	TW004G	39	UH4570	174	VR003C	53
PV301D	93	TW005G	39	UH4861	174	VR003G	53
PV7000C	93	TW007G	39	UH5261	174	VR004C	53
PV7001C	93	TW008G	39	UH5570	174	VR004G	53
PW5000C	93	TW010G	39	UH5580	174	VS001G	145
PW5001C	93	TW0200	42	UH6570	174	W	
R		TW0350	41	UH6580	174	WA400MP	164
RD1101	130	TW060D	41	UH7580	174	WR100D	42
RF1101	130	TW1000	41	UM164D	166	WT001G	42
RM350D	153	TW100D	41	UM167D	166		
RP001G	129	TW140D	41	UM600D	166		
RP0900	130	TW141D	41	UN001G	175		
RP0910	130	TW160D	41	UN460WD	175		
RP1101	130	TW161D	40	UP100D	176		
RP1111C	130	TW202D	41	UR002G	159		
RP1800	130	U		UR003G	160		
RP1800F	129	UA001G	171	UR006G	159		
RP1802	129	UA002G	171	UR007G	159		
RP1802F	129	UA003G	171	UR008G	159		
RP1803	129	UA004G	171	UR012G	159		
RP1803F	129	UB001G	149	UR013G	159		
RP2300FC	129	UB003C	149	UR014G	159		
RP2301FC	129	UB004C	149	UR016G	160		
RP2302FC	129	UB100D	150	UR017G	160		
RP2303FC	129	UB101D	150	UR100D	161		
RS001G	118	UB1102	150	UR101C	159		
RS002G	118	UB1103	150	UR140D	161		
RT001G	128	UB400MP	164	UR180D	161		
RT0700C	128	UB401MP	164	UR201C	159		
RT0702C	128	UB402MP	164	UR202C	159		



2025 New Products



New Products

Cordless Impact Driver

40Vmax

TD004G p.32



Cordless Angle Screwdriver

18V

DFL126F / DFL303F / DFL404F p.49



DFL126F

DFL303F / DFL404F

Cordless Belt Sander

40Vmax

BS001G p.100



Cordless Impact Driver

18V

DTD173 p.32



Combination Hammer

AC

HR2670FT / HR2670 p.61



HR2670FT

HR2670

Cordless Power Cutter

40Vmax

CE004G / CE003G p.104



CE004G

CE003G

Drill

AC

DP4021 / DP4020 p.35



DP4021

DP4020

Angle Grinder

AC

955HNR p.83



Cordless Hole Puncher

40Vmax

PP001G p.107



Cordless Impact Wrench

40Vmax

TW010G p.39



Angle Grinder

AC

GA7090 / GA9090 p.87



GA7090

GA9090

Cordless Cable Cutter

18V

DTC100 / DTC101 p.109



DTC100

DTC101

Cordless Impact Wrench

40Vmax

TW002G / TW003G p.39



TW002G

TW003G

Battery Powered Random Orbit Sander

40Vmax

 BO001CG / BO002CG p.96
 BO003CG / BO004CG p.97

BO001CG / BO003CG

BO002CG / BO004CG

Cordless Cable Cutter

18V

DTC102 / DTC103 p.109



DTC102

DTC103

Cordless Auto Feed Screwdriver

18V

DFR453 / DFR552 p.44



DFR453

DFR552

Battery Powered Orbital Sander

40Vmax

 BO005CG / BO006CG p.97
 BO007CG p.97

BO005CG

BO007CG

BO006CG

Cordless Multi Tool

40Vmax

TM001G p.110



Cordless Circular Saw

40Vmax

HS013G p.116



Cordless Edger

40Vmax

UE001G p.162



Rechargeable Rotary Laser

40Vmax / 18V / 12Vmax

SKR001 p.181



Cordless Router

40Vmax

RP001G p.129



Cordless Chain Saw

40Vmax

UC026G / UC025G / UC024G p.168
UC023G / UC022G / UC021G p.168



Cordless Job Site Speaker

40Vmax / 18V

MR014G p.191



Cordless Framing Nailer

18V

DBN900 / DBN901 p.138



Cordless Pruning Saw

40Vmax

UC029G p.170



Cordless Pressure Washer

18V

DHW180 p.151



Cordless Pole Saw

18V

DUA200 p.171

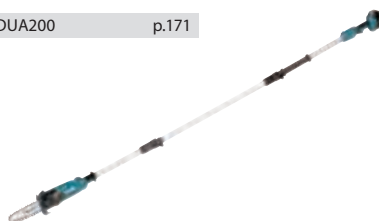

Cordless Polisher Scrubber

40Vmax

PS001G p.151



Cordless Hedge Trimmer

40Vmax

UH020G / UH021G p.172



Cordless Scarifier

18V

DUV320 p.157



Cordless Pole Hedge Trimmer

40Vmax

UN001G p.175





XGT Battery Series



Max Output

0.9 kW



Max Output

1.1 kW



Max Output

1.5 kW



2.0 Ah BL4020



2.5 Ah BL4025



4.0 Ah BL4040

XGT is a new system with its own tools, batteries, and chargers. A combination of innovative tool design and higher output batteries provide a genuine solution for high demand industrial users.

Optimum power supply system and Optimum charging system

The XGT range of tools and batteries come with a built-in program, providing digital communication between the battery and tool. Allowing not only for the battery to talk with tool but also the tool to talk to the battery. Battery technology and motor engineering that work together for optimum performance.

Tool ◀▶ Battery ◀▶ Battery Charger
Digital communication

Optimum charging system

Auto maintenance system with two cooling fans for providing more optimum fast charging



40Vmax mechanism movie

This movie was filmed in Japan. Models and specs may vary by country.



Max Output 2.1 kW

Max Output 2.8 kW

POWER

4.0 Ah BL4040F | 5.0 Ah BL4050F | 8.0 Ah BL4080F

Built Tough

High durability specifications specially designed for 40Vmax Li-Ion batteries

4-LED fuel gauge indicator



Terminal short-circuit prevention structure
The protection wall is provided between terminals against water and dust.

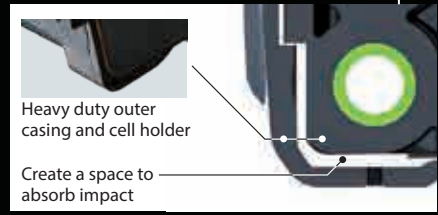

Shock absorption structure

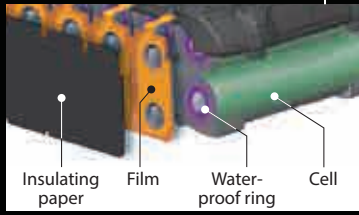

Waterproof Triple-layer Structure
prevents cell failure due to water and dust.

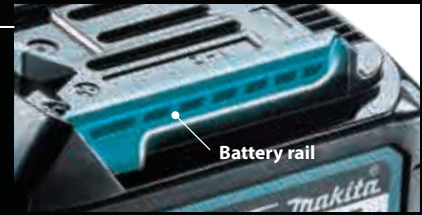

High Rigidity Battery Rails
Durable slide in battery rail that holds the battery and the tools firmly and securely to withstand high power products

High Output Battery Series



BL4040F
[Tab-less]



BL4050F



BL4080F



Unlocks the full power potential for certain models.



Demonstrates tenacity even under heavy load.

BL4040F Tab-less Battery

Traditional



Higher electrical resistance

Energy converts to heat

Leading to energy loss

Tab-less

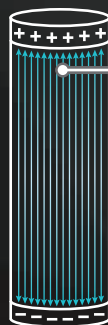

Lower electrical resistance

Energy does not easily convert to heat

Minimal energy loss

BL4050F (Traditional)



20 cells
(2P10S)

BL4040F (Tab-less)



10 cells
(1P10S)



Unlocks the full power potential for certain models.

By using the high output battery, the overload indicator setting changes thanks to the smart system, allowing for continuous heavy load work, thereby improving efficiency and unlocking the full power of certain models.

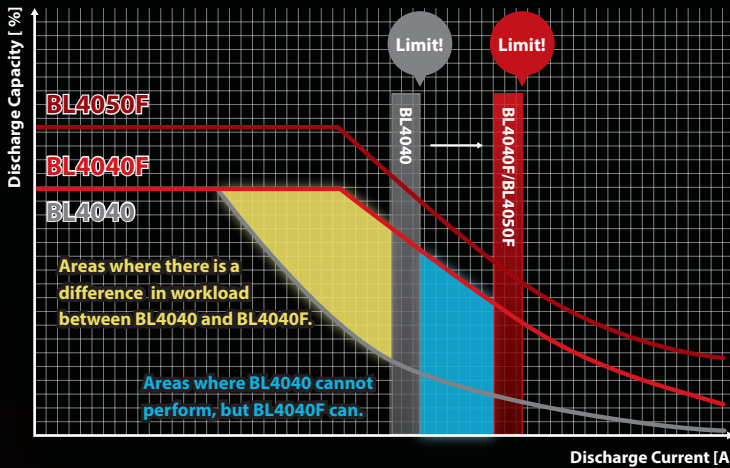

Cordless Chain Saw
UC017G (42cc Class)
Cutting ø300mm cedar log

Standard [BL4040]	9.7 sec.
High Output Battery [BL4040F / BL4050F]	6.9 sec. UP TO 29% FASTER



Demonstrates tenacity even under heavy load.

By using the high output battery, it is less likely to slow down under heavy load, demonstrating tenacity and leading to increased efficiency. Despite having the same battery capacity, the work output per charge with the BL4040F can be higher than the BL4040 under high load conditions.

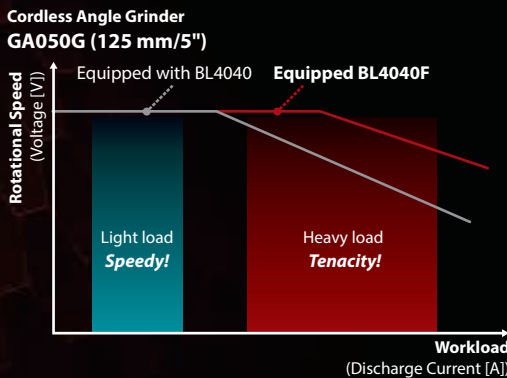

Cordless Angle Grinder
GA038G (230mm/9")
Cutting concrete continuously at depth of 40mm

Work amount per charge

Standard [BL4040]	240 cm
High Output Battery [BL4040F / BL4050F]	410 cm UP TO 71% LONGER

Achieves increased continuous output performance under heavy load, which is equivalent to BL4050F, while maintaining the same size as BL4040.



vs BL4040



36%
MORE POWER



32%
COOLER

vs BL4050F



28%
LESS WEIGHT



32%
MORE COMPACT



40V Li-ion max

High Power

Durability

Digital Communication

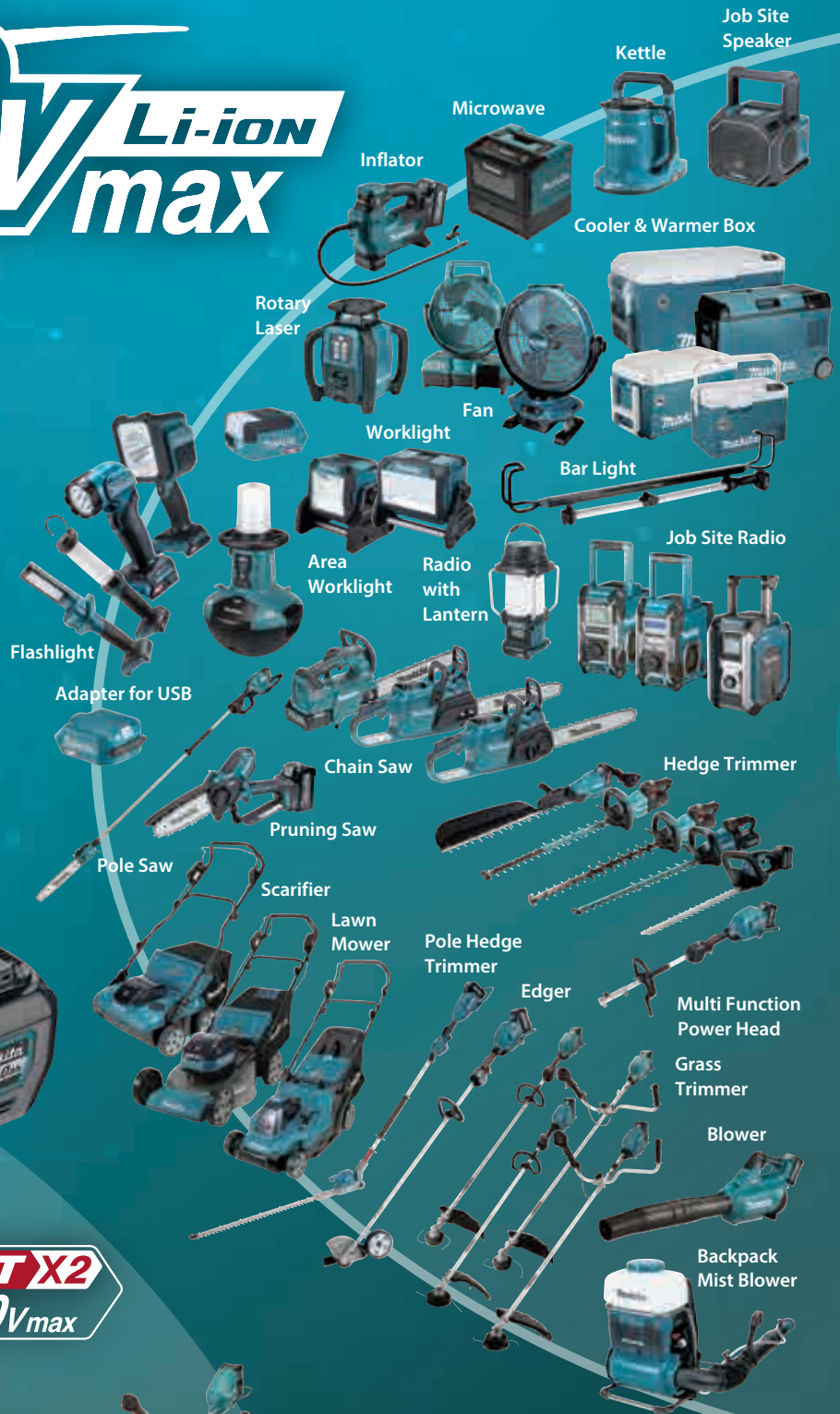

Rotary Hammer



Demolition Hammer



Power Cutter

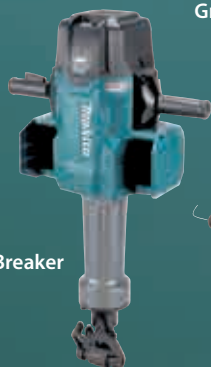

Breaker



Grass Trimmer



Vacuum Cleaner

Battery

BL4020
2.0Ah

BL4025
2.5Ah

BL4040 /
BL4040F
4.0Ah



Impact Driver



Driver Drill



Hammer Driver Drill



Rotary Hammer



Demolition Hammer



Combination Hammer



Brad Nailer



Impact Wrench



Angle Drill



Earth Auger



Shear Wrench



Mixer



Concrete Vibrator



Polisher



Air Compressor



Communication connector



230+ TOOLS

Rear Handle Saw



Angle Grinder



Multi Tool



Random Orbit Sander



Orbital Sander



Belt Sander



Metal Cutter



Power Cutter



Hole Puncher



Plunge Cut Saw



Jig Saw



Slide Compound Miter Saw



Circular Saw

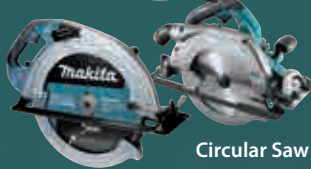

Planer



Recipro Saw



Portable Band Saw



Dust Blower



High Pressure Washer



Backpack Vacuum Cleaner



Polisher Scrubber



Vacuum Sweeper



Vacuum Cleaner



Upright Cleaner



Cleaner



Trimmer



Router



Charger

BL4050F 5.0Ah



BL4080F 8.0Ah



DC40RA



DC40RB



DC40WA



DC40RC



ADP10



Adapter for LXT Battery

18V LITHIUM-ION



18V Lithium-ion

Portable Cut-off

Power Cutter

Plunge Cut Saw

Angle Grinder

Angle Drill

Backpack Vacuum Cleaner

Upright Cleaner

Fan

Recipro Saw

Rear Handle Saw

Rotary Hammer

Combination Hammer

Coffee Maker

Inflator

Job Site Speaker

Cooler & Warmer Box

LED Worklight

Radio with Lantern

Job Site Radio

Pruning Shears

Chain Saw

Pole Saw

Pruning Saw

Lawn Mower

Blower

Blower Vacuum

Planer

Rivet Gun

Trimmer

Brad Nailer

Framing Nailer

Drywall Saw

Circular Saw

Rebar Tying Tool

Stapler

Cut-Out Tool

Pin Nailer

Finish Nailer

Jig Saw

Plate Joiner

Cyclone Cleaner

Multi Function Power Head

Grass Trimmer

String Trimmer

Pressure Washer

Garden Sprayer

Hedge Trimmer

Grass Shear

Scarifier

Wheelbarrow

Worklight

Flashlight

LED Flashlight

Heated Blanket

Heated Jacket

Heated Base Layer Shirt

Heated Vest

Fan Jacket

Fan Vest

Grease Gun

Caulking Gun

Vacuum Pump

Heat Gun

Slide Compound Miter Saw

Bar Light

Rotary Laser

Worklight

Worklight

Worklight

Worklight

Worklight

Worklight

Worklight

Worklight

Worklight

Worklight

Worklight





Chain Saw

Pole Saw

Grass Trimmer

Pruning Shears

Lawn Mower

Earth Auger

Vacuum Pump

High Pressure Washer

Wheelbarrow

Kettle

Portable Power Pack

Impact Wrench

Blower

Vacuum Cleaner

Multi Function Power Head

Auto Feed Screwdriver

Oil-Pulse Driver

Concrete Vibrator

Mixer

4 Mode Impact Driver

Screwdriver

18V x2

430+ TOOLS

6.0Ah 5.0Ah 4.0Ah 3.0Ah 2.0Ah 1.5Ah

Angle Drill

Angle Impact Wrench

Driver Drill

Impact Driver

Angle Impact Driver

Angle Impact Driver

Ratchet Wrench

Hammer Driver Drill

Rotary Hammer

Die Grinder

Sander Polisher

Power Scraper

Combination Hammer

Steel Rod Cutter

Multi Tool

Finishing Sander

Random Orbit Polisher

Angle Grinder

Recipro Saw

Metal Shear

Drywall Sander

Random Orbit Sander

Threaded Rod Cutter

Compact Cut Off

Hole Puncher

Belt Sander

Nibbler

Cable Cutter

Cutter

Metal Cutter

Portable Band Saw

Slide Compound Miter Saw

Compound Miter Saw

Expand Your Lithium Line Up

12V_{max} LITHIUM-ION

90+ TOOLS
EXPAND YOUR LITHIUM-ION LINEUP

4.0Ah 2.0Ah 1.5Ah

- Job Site Radio
- Job Site Speaker
- Rotary Laser
- Multi Line Laser
- Green Multi Line Laser
- Green 4-point Cross Line Laser
- Red 4-point Cross Line Laser
- Heated Jacket
- Heated Vest
- Heated Base Layer Shirt
- Heated Blanket
- Fan
- Fan Vest
- Fan Jacket
- Worklight
- Cordless Cleaner
- LED Worklight
- Inflator
- Blower
- Hedge Trimmer
- Pruning Saw
- Pruning Shears
- Garden Sprayer
- Caulking Gun
- Driver Drill
- Hammer Driver Drill
- Impact Driver
- Angle Drill
- Adapter for USB
- Impact Wrench
- Rotary Hammer
- Ratchet Wrench
- Angle Impact Driver
- Multi Cutter
- Threaded Rod Cutter
- Cutter
- Recipro Saw
- Drywall Saw
- Multi tool
- Pin Nailer
- Stapler
- Sander Polisher
- Jig Saw
- Circular Saw



10.8V Lithium-ion



7.2V Lithium-ion



18V Lithium-ion



A wide variety of Lithium-ion Garden Tools

40V max x2
Direct power connection

Pruning Saw
High Pressure Washer*
Blower
Grass Trimmer*
Power Cutter*

64V max
Direct power connection

Grass Trimmer
Lawn Mower
Blower
Backpack Blower

18V
Build in battery

Grass Shear
String Trimmer
Hedge Trimmer
Pruning Saw
Pruning Shears
Recipro Saw
Blower
Pole Hedge Trimmer
Garden Sprayer
Grass Shear
Hedge Trimmer
Grass Trimmer
Robotic Mower
Garden Sprayer*
Scarifier*

12V max
Build in battery

PDC1500 / PDC1200
PDC01

* These models are not compatible with Portable Power Pack (PDC1500, PDC1200, PDC01)
Only rear handle type chainsaws are compatible

** These models are not compatible with Portable Power Pack (PDC1500, PDC1200)

***This model is not compatible with Portable Power pack (PDC1500)

40V max

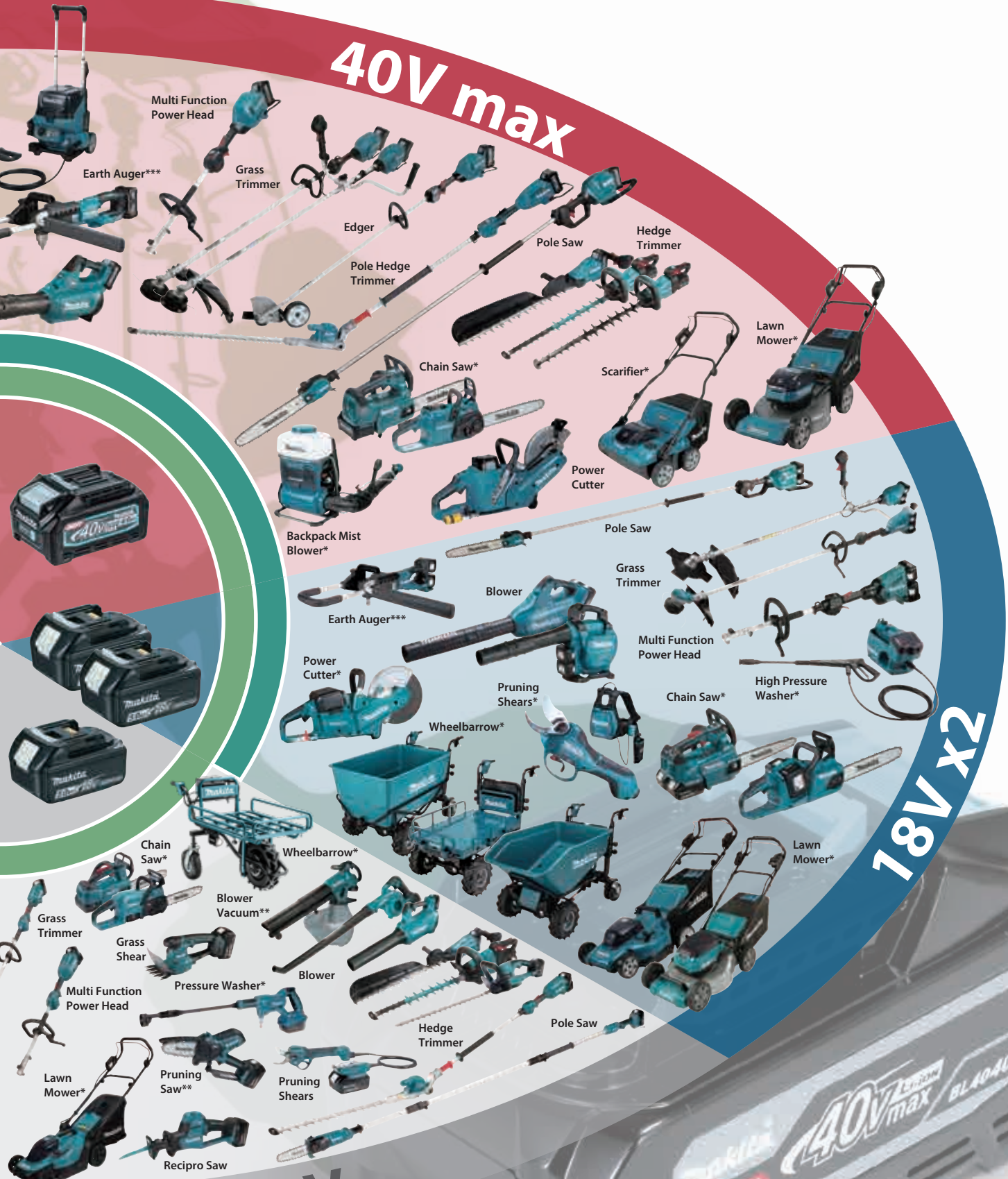

18V x2



Multi Function Power Head

Earth Auger***

Grass Trimmer

Edger

Pole Hedge Trimmer

Pole Saw

Hedge Trimmer

Lawn Mower*

Chain Saw*

Scarifier*

Power Cutter

Backpack Mist Blower*

Pole Saw

Earth Auger***

Blower

Grass Trimmer

Multi Function Power Head

High Pressure Washer*

Power Cutter*

Pruning Shears*

Chain Saw*

Wheelbarrow*

Chain Saw*

Wheelbarrow*

Blower Vacuum**

Grass Trimmer

Grass Shear

Pressure Washer*

Blower

Multi Function Power Head

Hedge Trimmer

Pole Saw

Lawn Mower*

Pruning Saw**

Pruning Shears

Recipro Saw

18V



Rapid Optimum Charging System

It is necessary to cool down before start charging when the battery temperature is high.
Built-in fan circulates air through the battery before start charging and during the charging process to cool the battery for faster charge time.

The optimum charging system



General charging method



The Makita Rapid Optimum Charger communicates with the battery's built-in chip throughout the charging process to optimize battery life by actively controlling current, voltage and temperature.



The optimum charging system

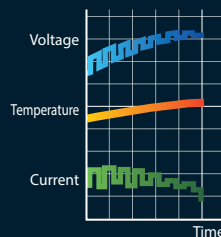

General charging method

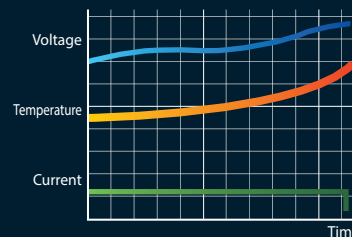

Li-ion Battery & Charging Time Reference, Compatibility Chart

40Vmax 18V		Fast Charging DC40RA	DC40RC	DC40WA*1	Fast Charging DC40RA + ADP10	DC40RC + ADP10	Fast Charging DC18RC	DC18SF Except BL1430A	DC18SD DC18SH*1 DC18SE (Automotive)	DC18WC	
40Vmax Lithium-ion XGT	8.0Ah BL4080F	76min.	170min.	420min.	-	-	-	-	-	-	
	5.0Ah BL4050F	50min.	85min.	260min.	-	-	-	-	-	-	
	4.0Ah BL4040F BL4040	45min.	67min.	210min.	-	-	-	-	-	-	
	2.5Ah BL4025	28min.	38min.	130min.	-	-	-	-	-	-	
	2.0Ah BL4020	22min.	30min.	110min.	-	-	-	-	-	-	
18V Lithium-ion LXT	6.0Ah BL1860B	-	-	-	40min.	85min.	55min.	1 to 2 batteries 130 min.	3 to 4 batteries 260 min.	130min.	160min.
	5.0Ah BL1850B	-	-	-	35min.	70min.	45min.	110 min.	220 min.	110min.	135min.
	4.0Ah BL1840B	-	-	-	29min.	58min.	36min.	90 min.	180 min.	90min.	110min.
	3.0Ah BL1830B	-	-	-	22min.	42min.	22min.	60 min.	120 min.	60min.	80min.
	2.0Ah BL1820B	-	-	-	24min.	33min.	24min.	45 min.	90 min.	45min.	55min.
	1.5Ah BL1815N	-	-	-	15min.	22min.	15min.	30 min.	60 min.	30min.	40min.

*1 DC40RB / DC40WA / DC18RD / DC18SH: Two Port Multi Charger *2 DC18RE: CXT & LXT Dual port Fast Charger



Battery Charging Case BCC01 / BCC02

With multiple charging ports for 40Vmax XGT Li-Ion batteries

BCC01: 8 ports

Switch charging of batteries attached to multiple ports
 Capable of charging all batteries on four ports simultaneously. Equipped with a feature that automatically switches batteries to charge them.

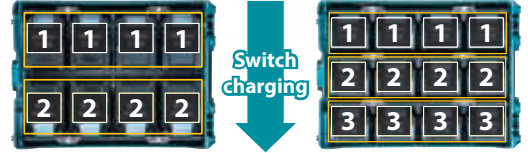

BCC02: 12 ports

18V batteries can be charged using an adapter
 BCC01 only

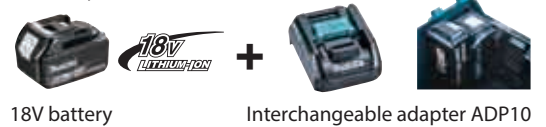

Li-ion Battery & Charging Time Reference, Compatibility Chart

12V max Lithium-ion CXT		Fast Charging DC10SB DC18RE*2	DC10WD	PDC1200	PDC1500	DC4001	PDC01		
5.0Ah BL1050B	75min.	160min.		35.5Ah PDC1200	360min.		40Vmax Lithium-ion 18V x2 Lithium-ion 18V Lithium-ion Powered by up to four 18V LXT Batteries		
4.0Ah BL1041B	60min.	130min.		43.55Ah PDC1500	450min.				
2.0Ah BL1021B	30min.	70min.							
1.5Ah BL1016	22min.	50min.							
64V max Lithium-ion		DC64WA	10.8V 7.2V	DC10WA	DC10WB	18V	DC18WA DC18WB		
10.0Ah BL64100	300min.	10.8V Lithium-ion	1.5Ah BL1015K	55min.	55min.	18V Lithium-ion	1.5Ah BL1815G	70min.	80min.
4.0Ah BL6440	120min.	7.2V Lithium-ion	1.5Ah BL0715	35min.	35min.		2.0Ah BL1820G	90min.	105min.

*2 DC18RE: CXT & LXT Dual port Fast Charger



Power Converter BAC01

Power converter powered by Makita portable power pack (BAC01 + PDC1200 / PDC1500)

The device, which converts DC power into AC power, is optimal for a wide range of applications.

AC output | 50/60 Hz switchable with pure sine wave

Max output
 Rating value for 4 seconds
2,800 w(VA)

Continuous rating output
1,400 w(VA)

Output port

- AC output*3 x2
- USB output Type-A x2
- USB output Type-C x2
- DC output 12V/10A Cigar socket

*3 Output voltage and outlet shape vary depending on the country.

Portable Power Pack

PDC1500

Powered by 36V-40Vmax built-in battery
1,500Wh-class high capacity

IPX4

Charger: DC4001
Charging time: 450 min



PDC1200

Powered by 36V-40Vmax built-in battery
1,200 Wh high capacity

IPX4

Charger: DC4001
Charging time: 360 min



PDC01

Powered by up to four 18V LXT batteries

432 Wh high capacity
(with 4 pcs. of BL1860B)

IPX4



Battery Powered Models



UR101C
UR201C
UR202C



UB003C

UB004C

VR001C
VR003C
VR004C

LM001C

Adapter set



+

XGT
40Vmax
LITHIUM



Adapter set



+

18V + 18V → **36V**



Adapter set



+

18V
LITHIUM-ION



Portable Power Pack

	PDC1500	PDC1200	PDC01
Capacity	43.55 Ah	33.5 Ah	24 / 12 Ah
Dimensions (L x W x H)	w/o Harness: 369 x 312 x 131 mm (14-1/2 x 12-1/4 x 5-1/8") w/ Harness: 516 x 312 x 193 mm (20-1/4 x 12-1/4 x 7-5/8")	w/o Harness: 369 x 261 x 139 mm (14-1/2 x 10-1/4 x 5-1/2") w/ Harness: 428 x 261 x 164 mm (16-7/8 x 10-1/4 x 6-1/2")	w/o Harness: 400 x 195 x 132 mm (15-3/4 x 7-5/8 x 5-3/16") w/ Harness: 400 x 270 x 149 mm (15-3/4 x 10-5/8 x 5-7/8")
Net weight	11.1 - 13.0 kg (24.5 - 28.7 lbs.)	8.8 kg (19.4 lbs.)	2.8 kg (6.1 lbs.)

MAKPAC Power source kit

MAKPAC trolley

able to stack on for easy loading



MAKPAC adapter set

Makita AC Vacuum Cleaner
to connect with MAKPAC

Model No.
VC001G, L VC002GL, VC003GL, VC004GL,
VC005GL, VC3211H/M, VC2211M, VC2201M,
VC1310L, VC2510L, VC3210L



MAKPAC organizer

ideal for accessory cases

- MAKPAC organizer set
- MAKPAC organizer set (No box)



Cool Box

























20mm thickness formed polystyrene, sealing strips are placed around the mating surface of lid and box.



PRODUCTS

Screwing/Drilling



-  Double Insulation
-  Variable Speed
-  Brake
-  Reversing
-  Anti-restart function
-  Mechanical 2-Speed
-  Mechanical 3-Speed
-  Electronic 2-Speed
-  Electronic 3-Speed
-  Electronic 4-Speed
-  Keyless Chuck
-  Torque Setting 6
-  Torque Setting 9
-  Torque Setting 16
-  Torque Setting 18
-  Torque Setting 20
-  Torque Setting 21
-  Torque Setting 21/41
-  Clutch-equipped
-  Torque Limiter
-  Constant Speed
-  Soft Start
-  Built-in Job Light
-  Carrying Case

Cordless Hammer Driver Drill / Cordless Driver Drill

High



Low

XGT

BL MOTOR Brushless Motor

40V max **150 N-m**

HP001G DF001G

XGT BL AFT XPT



40V max **70 N-m**

HP002G DF002G

XGT BL XPT







LXT

BL MOTOR Brushless Motor

18V **141 N-m**

DHP486 DDF486





   

LXT BL XPT



18V **110 N-m**

DHP489 DDF489





   

LXT BL XPT



18V **65 N-m**

DHP484 DDF484



   

LXT BL XPT



18V **60 N-m**

DHP485 DDF485





   

LXT BL XPT



18V **40 N-m**

DHP487 DDF487



   

LXT BL XPT



18V **40 N-m**

DDF083

LXT BL XPT



Brushed Motor

18V **110 N-m**

DHP458 DDF458

LXT XPT



18V **63 N-m**

DHP451 DDF451

LXT



18V **64 N-m**

DHP482 DDF482

LXT XPT



18V **48 N-m**

DHP453 DDF453

LXT



Screwing/Drilling

Cordless Driver Drill DF001G

40V max



No load speed	High: 0 - 2,600 min ⁻¹ Low: 0 - 650 min ⁻¹
Max torque	150 N·m (1,300 in.lbs.)
Max fastening torque	Hard: 140 N·m (1,240 in.lbs.) Soft: 68 N·m (600 in.lbs.)
Capacity	Wood (Self-feed bit): 76 mm (3") Steel: 20 mm (13/16") Wood (Auger-Bit): 50 mm (2")
Chuck capacity	1.5 - 13 mm (1/16 - 1/2")
Dimensions (L x W x H)	w/ BL4040: 181 x 86 x 282 mm (7-1/8 x 3-3/8 x 11-1/8")
Net weight	2.7 - 3.0 kg (5.9 - 6.6 lbs.)

XGT BL AFT XPT



Cordless Hammer Driver Drill HP001G

40V max



No load speed	High: 0 - 2,600 min ⁻¹ Low: 0 - 650 min ⁻¹
Impacts per minute	High: 0 - 39,000 min ⁻¹ Low: 0 - 9,750 min ⁻¹
Max torque	150 N·m (1,300 in.lbs.)
Max fastening torque	Hard: 140 N·m (1,240 in.lbs.) Soft: 68 N·m (600 in.lbs.)
Capacity	Wood (Self-feed bit): 76 mm (3") Steel: 20 mm (13/16") Masonry: 20 mm (13/16")
Chuck capacity	1.5 - 13 mm (1/16 - 1/2")
Dimensions (L x W x H)	w/ BL4040: 182 x 86 x 282 mm (7-1/8 x 3-3/8 x 11-1/8")
Net weight	2.7 - 3.0 kg (6.0 - 6.6 lbs.)

XGT BL AFT XPT



Cordless Driver Drill DF002G

40V max



No load speed	High: 0 - 2,200 min ⁻¹ Low: 0 - 600 min ⁻¹
Max torque	70 N·m (620 in.lbs.)
Max fastening torque	Hard: 64 N·m (570 in.lbs.) Soft: 30 N·m (270 in.lbs.)
Capacity	Wood (Self-feed bit): 51 mm (2") Wood (Auger-Bit): 38 mm (1-1/2")
Chuck capacity	1.5 - 13 mm (1/16 - 1/2")
Dimensions (L x W x H)	w/ BL4050F: 164 x 86 x 294 mm (6-1/2 x 3-3/8 x 11-5/8")
Net weight	1.9 - 2.5 kg (4.2 - 5.5 lbs.)

XGT BL XPT



Cordless Hammer Driver Drill HP002G

40V max



No load speed	High: 0 - 2,200 min ⁻¹ Low: 0 - 600 min ⁻¹
Impacts per minute	High: 0 - 33,000 min ⁻¹ Low: 0 - 9,000 min ⁻¹
Max torque	70 N·m (620 in.lbs.)
Max fastening torque	Hard: 64 N·m (570 in.lbs.) Soft: 30 N·m (270 in.lbs.)
Capacity	Wood (Self-feed bit): 51 mm (2") Steel: 13 mm (1/2") Masonry: 13 mm (1/2")
Chuck capacity	1.5 - 13 mm (1/16 - 1/2")
Dimensions (L x W x H)	w/ BL4050F: 174 x 86 x 294 mm (6-7/8 x 3-3/8 x 11-5/8")
Net weight	2.0 - 2.6 kg (4.4 - 5.7 lbs.)

XGT BL XPT



Cordless Driver Drill DDF486

18V



No load speed	High: 0 - 2,100 min ⁻¹ Low: 0 - 550 min ⁻¹
Max torque	141 N·m (1,250 in.lbs.)
Max fastening torque	Hard: 130 N·m (1,150 in.lbs.) Soft: 65 N·m (580 in.lbs.)
Capacity	Wood (Self-feed bit): 76 mm (3") Steel: 20 mm (13/16") Wood (Auger-Bit): 50 mm (2")
Chuck capacity	1.5 - 13 mm (1/16 - 1/2")
Dimensions (L x W x H)	w/ BL1830B / BL1840B / BL1850B / BL1860B: 178 x 81 x 265 mm (7 x 3-3/16 x 10-3/8")
Net weight	2.3 - 2.6 kg (5.1 - 5.7 lbs.)

LXI BL XPT



Cordless Hammer Driver Drill DHP486

18V



No load speed	High: 0 - 2,100 min ⁻¹ / Low: 0 - 550 min ⁻¹
Impacts per minute	High: 0 - 31,500 min ⁻¹ Low: 0 - 8,250 min ⁻¹
Max torque	141 N·m (1,250 in.lbs.)
Max fastening torque	Hard: 130 N·m (1,150 in.lbs.) Soft: 65 N·m (580 in.lbs.)
Capacity	Wood (Self-feed bit): 76 mm (3") Steel: 20 mm (13/16") Masonry: 20 mm (13/16")
Chuck capacity	1.5 - 13 mm (1/16 - 1/2")
Dimensions (L x W x H)	w/ BL1830B / BL1840B / BL1850B / BL1860B: 178 x 81 x 265 mm (7 x 3-3/16 x 10-3/8")
Net weight	2.3 - 2.7 kg (5.1 - 6.0 lbs.)

LXI BL XPT



Cordless Driver Drill DDF489

18V



No load speed	High: 0 - 1,800 min ⁻¹ Low: 0 - 550 min ⁻¹
Max torque	110 N·m (970 in.lbs.)
Max fastening torque	Hard: 73 N·m (650 in.lbs.) Soft: 40 N·m (350 in.lbs.)
Capacity	Wood (Self-feed bit): 51 mm (2") Wood (Auger-Bit): 38 mm (1-1/2")
Chuck capacity	1.5 - 13 mm (1/16 - 1/2")
Dimensions (L x W x H)	w/ BL1830B / BL1840B / BL1850B / BL1860B: 174 x 81 x 261 mm (6-7/8 x 3-3/16 x 10-1/4")
Net weight	1.8 - 2.5 kg (4.0 - 5.5 lbs.)

LXI BL XPT



Cordless Hammer Driver Drill DHP489

18V



No load speed	High: 0 - 1,800 min ⁻¹ / Low: 0 - 550 min ⁻¹
Impacts per minute	High: 0 - 27,000 min ⁻¹ Low: 0 - 8,250 min ⁻¹
Max torque	110 N·m (970 in.lbs.)
Max fastening torque	Hard: 73 N·m (650 in.lbs.) Soft: 40 N·m (350 in.lbs.)
Capacity	Wood (Self-feed bit): 51 mm (2") Steel: 13 mm (1/2") Masonry: 16 mm (5/8")
Chuck capacity	1.5 - 13 mm (1/16 - 1/2")
Dimensions (L x W x H)	w/ BL1830B / BL1840B / BL1850B / BL1860B: 175 x 81 x 261 mm (6-7/8 x 3-3/16 x 10-1/4")
Net weight	1.8 - 2.5 kg (4.0 - 5.5 lbs.)

LXI BL XPT



Cordless Driver Drill DDF484

18V



No load speed	High: 0 - 2,000 min ⁻¹ Low: 0 - 500 min ⁻¹
Max torque	65 N·m (580 in.lbs.)
Max fastening torque	Hard: 54 N·m (480 in.lbs.) Soft: 30 N·m (270 in.lbs.)
Capacity	Wood (Self-feed bit): 76 mm (3") Steel: 13 mm (1/2") Wood (Auger-Bit): 38 mm (1-1/2")
Chuck capacity	1.5 - 13 mm (1/16 - 1/2")
Dimensions (L x W x H)	172 x 79 x 261 mm (6-3/4 x 3-1/8 x 10-1/4")
Net weight	1.5 - 1.8 kg (3.3 - 4 lbs.)

LXI BL XPT



Cordless Hammer Driver Drill DHP484

18V



No load speed	High: 0 - 2,000 min ⁻¹ / Low: 0 - 500 min ⁻¹
Impacts per minute	High: 0 - 30,000 min ⁻¹ Low: 0 - 7,500 min ⁻¹
Max torque	65 N·m (580 in.lbs.)
Max fastening torque	Hard: 54 N·m (480 in.lbs.) Soft: 30 N·m (270 in.lbs.)
Capacity	Wood (Self-feed bit): 76 mm (3") Steel: 13 mm (1/2") Masonry: 13 mm (1/2") Wood: 38 mm (1-1/2")
Chuck capacity	1.5 - 13 mm (1/16 - 1/2")
Dimensions (L x W x H)	182 x 79 x 261 mm (7-1/8 x 3-1/8 x 10-1/4")
Net weight	1.6 - 1.9 kg (3.5 - 4.2 lbs.)

LXI BL XPT



Screwing/Drilling

Cordless Driver Drill
DDF485

18V



No load speed	High: 0 - 1,900 min ⁻¹ Low: 0 - 500 min ⁻¹
Max torque	60 N·m (530 in.lbs.)
Max fastening torque	Hard: 50 N·m (440 in.lbs.) Soft: 27 N·m (240 in.lbs.)
Capacity	Wood (Self-feed bit): 76 mm (3") Steel: 13 mm (1/2") Wood (Auger-Bit): 38 mm (1-1/2")
Chuck capacity	1.5 - 13 mm (1/16 - 1/2")
Dimensions (L x W x H)	w/ BL1830B / BL1840B / BL1850B / BL1860B: 169 x 79 x 255 mm (7-1/8 x 3-1/8 x 10")
Net weight	1.4 - 1.7 kg (3.1 - 3.8 lbs.)

LXI BL MOTOR XPT

Cordless Driver Drill
DDF487

18V



No load speed	High: 0 - 1,700 min ⁻¹ Low: 0 - 500 min ⁻¹
Max torque	40 N·m (350 in.lbs.)
Max fastening torque	Hard: 40 N·m (350 in.lbs.) Soft: 25 N·m (220 in.lbs.)
Capacity	Wood (Self-feed bit): 35 mm (1-3/8") Steel: 13 mm (1/2") Wood (Auger-Bit): 36 mm (1-7/16")
Chuck capacity	1.5 - 13 mm (1/16 - 1/2")
Dimensions (L x W x H)	w/ BL1830B / BL1840B / BL1850B / BL1860B: 150 x 81 x 248 mm (5-7/8 x 3-3/16 x 9-3/4")
Net weight	1.3 - 1.6 kg (2.9 - 3.5 lbs.)

LXI BL MOTOR XPT

Cordless Driver Drill
DDF458

18V



No load speed	High: 0 - 2,000 min ⁻¹ Low: 0 - 400 min ⁻¹
Max torque	110 N·m (970 in.lbs.)
Max fastening torque	Hard: 91 N·m (810 in.lbs.) Soft: 58 N·m (520 in.lbs.)
Capacity	Wood (Self-feed bit): 92 mm (3-5/8") Steel: 13 mm (1/2") Wood: 76 mm (3")
Chuck capacity	1.5 - 13 mm (1/16 - 1/2")
Dimensions (L x W x H)	225 x 79 x 259 mm (8-7/8 x 3-1/8 x 10-1/4")
Net weight	2.1 - 2.5 kg (4.7 - 5.4 lbs.)

LXI XPT

Cordless Driver Drill
DDF451

18V



No load speed	3rd: 0 - 1,700 min ⁻¹ 2nd: 0 - 600 min ⁻¹ 1st: 0 - 300 min ⁻¹
Max torque	63 N·m (560 in.lbs.)
Max fastening torque	Hard: 80 N·m (708 in.lbs.) Soft: 40 N·m (354 in.lbs.)
Capacity	Wood (Self-feed bit): 92 mm (3-5/8") Steel: 13 mm (1/2") Wood: 65 mm (2-9/16")
Chuck capacity	1.5 - 13 mm (1/16 - 1/2")
Dimensions (L x W x H)	238 x 78 x 257 mm (9-3/8 x 3-1/16 x 10-1/8")
Net weight	2.3 - 2.6 kg (5 - 5.7 lbs.)

LXI

Cordless Driver Drill
DDF482

18V



No load speed	High: 0 - 1,900 min ⁻¹ Low: 0 - 600 min ⁻¹
Max torque	64 N·m (570 in.lbs.)
Max fastening torque	Hard: 62 N·m (550 in.lbs.) Soft: 36 N·m (320 in.lbs.)
Capacity	Wood (Self-feed bit): 60 mm (2-3/8") Steel: 13 mm (1/2") Wood (Auger-Bit): 38 mm (1-1/2")
Chuck capacity	1.5 - 13 mm (1/16 - 1/2")
Dimensions (L x W x H)	185 x 79 x 249 mm (7-1/4 x 3-1/8 x 9-3/4")
Net weight	1.5 - 1.8 kg (3.2 - 4 lbs.)

LXI XPT

Cordless Hammer Driver Drill
DHP485

18V



No load speed	High: 0 - 1,900 min ⁻¹ / Low: 0 - 500 min ⁻¹
Impacts per minute	High: 0 - 28,500 min ⁻¹ / Low: 0 - 7,500 min ⁻¹
Max torque	60 N·m (530 in.lbs.)
Max fastening torque	Hard: 50 N·m (440 in.lbs.) Soft: 27 N·m (240 in.lbs.)
Capacity	Wood (Self-feed bit): 76 mm (3") Steel: 13 mm (1/2") Masonry: 13 mm (1/2") Wood: 38 mm (1-1/2")
Chuck capacity	1.5 - 13 mm (1/16 - 1/2")
Dimensions (L x W x H)	w/ BL1830B / BL1840B / BL1850B / BL1860B: 182 x 79 x 255 mm (7-1/8 x 3-1/8 x 10")
Net weight	1.5 - 1.8 kg (3.2 - 3.9 lbs.)

LXI BL MOTOR XPT

Cordless Hammer Driver Drill
DHP487

18V



No load speed	High: 0 - 1,700 min ⁻¹ / Low: 0 - 500 min ⁻¹
Impacts per minute	High: 0 - 25,500 min ⁻¹ Low: 0 - 7,500 min ⁻¹
Max torque	40 N·m (350 in.lbs.)
Max fastening torque	Hard: 40 N·m (350 in.lbs.) Soft: 25 N·m (220 in.lbs.)
Capacity	Wood (Self-feed bit): 35 mm (1-3/8") Steel: 13 mm (1/2") Masonry: 13 mm (1/2")
Chuck capacity	1.5 - 13 mm (1/16 - 1/2")
Dimensions (L x W x H)	w/ BL1830B / BL1840B / BL1850B / BL1860B: 164 x 81 x 248 mm (6-1/2 x 3-3/16 x 9-3/4")
Net weight	1.4 - 1.7 kg (3.1 - 3.7 lbs.)

LXI BL MOTOR XPT

Cordless Hammer Driver Drill
DHP458

18V



No load speed	High: 0 - 2,000 min ⁻¹ / Low: 0 - 400 min ⁻¹
Impacts per minute	High: 0 - 30,000 min ⁻¹ Low: 0 - 6,000 min ⁻¹
Max torque	110 N·m (970 in.lbs.)
Max fastening torque	Hard: 91 N·m (810 in.lbs.) Soft: 58 N·m (520 in.lbs.)
Capacity	Wood (Self-feed bit): 92 mm (3-5/8") Steel: 13 mm (1/2") Masonry: 16 mm (5/8") Wood: 76 mm (3")
Chuck capacity	1.5 - 13 mm (1/16 - 1/2")
Dimensions (L x W x H)	225 x 79 x 259 mm (8-7/8 x 3-1/8 x 10-1/4")
Net weight	2.2 - 2.6 kg (4.9 - 5.7 lbs.)

LXI XPT

Cordless Hammer Driver Drill
DHP451

18V



No load speed	3rd: 0 - 1,700 min ⁻¹ / 2nd: 0 - 600 min ⁻¹ / 1st: 0 - 300 min ⁻¹
Impacts per minute	3rd: 0 - 25,500 min ⁻¹ / 2nd: 0 - 9,000 min ⁻¹ / 1st: 0 - 4,500 min ⁻¹
Max torque	63 N·m (560 in.lbs.)
Max fastening torque	Hard: 80 N·m (708 in.lbs.) Soft: 40 N·m (354 in.lbs.)
Capacity	Steel: 13 mm (1/2") Masonry: 16 mm (5/8") Wood: 65 mm (2-9/16")
Chuck capacity	1.5 - 13 mm (1/16 - 1/2")
Dimensions (L x W x H)	250 x 78 x 257 mm (9-7/8 x 3-1/16 x 10-1/8")
Net weight	2.5 - 2.9 kg (5.6 - 6.3 lbs.)

LXI

Cordless Hammer Driver Drill
DHP482

18V



No load speed	High: 0 - 1,900 min ⁻¹ / Low: 0 - 600 min ⁻¹
Impacts per minute	High: 0 - 28,500 min ⁻¹ Low: 0 - 9,000 min ⁻¹
Max torque	64 N·m (570 in.lbs.)
Max fastening torque	Hard: 62 N·m (550 in.lbs.) Soft: 36 N·m (320 in.lbs.)
Capacity	Wood (Self-feed bit): 60 mm (2-3/8") Steel: 13 mm (1/2") Masonry: 13 mm (1/2") Wood: 38 mm (1-1/2")
Chuck capacity	1.5 - 13 mm (1/16 - 1/2")
Dimensions (L x W x H)	198 x 79 x 249 mm (7-3/4 x 3-1/8 x 9-3/4")
Net weight	1.5 - 1.8 kg (3.4 - 4.1 lbs.)

LXI XPT



Cordless Driver Drill DDF453

18V



No load speed	High: 0 - 1,300 min ⁻¹ Low: 0 - 400 min ⁻¹
Max torque	48 N·m (420 in.lbs.)
Max fastening torque	Hard: 42 N·m (372 in.lbs.) Soft: 27 N·m (239 in.lbs.)
Capacity	Wood (Self-feed bit): 72 mm (2-13/16") Steel: 13 mm (1/2") Wood: 36 mm (1-7/16")
Chuck capacity	1.5 - 13 mm (1/16 - 1/2")
Dimensions (L x W x H)	222 x 79 x 244 mm (8-3/4 x 3-1/8 x 9-5/8")
Net weight	1.7 - 2 kg (3.7 - 4.4 lbs.)

LXT



Cordless Hammer Driver Drill DHP453

18V



No load speed	High: 0 - 1,300 min ⁻¹ / Low: 0 - 400 min ⁻¹
Impacts per minute	High: 0 - 19,500 min ⁻¹ Low: 0 - 6,000 min ⁻¹
Max torque	48 N·m (420 in.lbs.)
Max fastening torque	Hard: 42 N·m (372 in.lbs.) Soft: 27 N·m (239 in.lbs.)
Capacity	Wood (Self-feed bit): 72 mm (2-13/16") Steel: 13 mm (1/2") Masonry: 13 mm (1/2") Wood: 36 mm (1-7/16")
Chuck capacity	1.5 - 13 mm (1/16 - 1/2")
Dimensions (L x W x H)	240 x 79 x 244 mm (9-7/16 x 3-1/8 x 9-5/8")
Net weight	1.7 - 2 kg (3.6 - 4.4 lbs.)

LXT



Cordless Driver Drill DDF083

18V



No load speed	High: 0 - 1,700 min ⁻¹ Low: 0 - 500 min ⁻¹
Max torque	40 N·m (350 in.lbs.)
Max fastening torque	Hard: 40 N·m (350 in.lbs.) Soft: 23 N·m (210 in.lbs.)
Capacity	Wood (Self-feed bit): 72 mm (2-13/16") Steel: 13 mm (1/2") Wood: 36 mm (1-7/16")
Chuck capacity	6.35 mm (1/4")
Dimensions (L x W x H)	124 x 79 x 247 mm (4-7/8 x 3-1/8 x 9-3/4")
Net weight	1.1 - 1.4 kg (2.4 - 3 lbs.)

LXT BL MOTOR XPT



Cordless Driver Drill DF032D

12V max



No load speed	High: 0 - 1,500 min ⁻¹ Low: 0 - 450 min ⁻¹
Max torque	38 N·m (340 in.lbs.)
Max fastening torque	Hard: 35 N·m (310 in.lbs.) Soft: 21 N·m (190 in.lbs.)
Capacity	Wood (Self-feed bit): 56 mm (2-3/16") Steel: 10 mm (3/8") Wood: 28 mm (1-1/8")
Chuck capacity	6.35 mm (1/4")
Dimensions (L x W x H)	124 x 66 x 217 mm (4-7/8 x 2-5/8 x 8-1/2")
Net weight	0.88 - 1 kg (1.9 - 2.3 lbs.)

CXT BL MOTOR XPT



Cordless Driver Drill DF332D

12V max



No load speed	High: 0 - 1,500 min ⁻¹ Low: 0 - 450 min ⁻¹
Max torque	38 N·m (340 in.lbs.)
Max fastening torque	Hard: 35 N·m (310 in.lbs.) Soft: 21 N·m (190 in.lbs.)
Capacity	Wood (Self-feed bit): 56 mm (2-3/16") Steel: 10 mm (3/8") Wood: 28 mm (1-1/8")
Chuck capacity	0.8 - 10 mm (1/32 - 3/8")
Dimensions (L x W x H)	154 x 66 x 217 mm (6-1/16 x 2-5/8 x 8-1/2")
Net weight	1 - 1.2 kg (2.3 - 2.6 lbs.)

CXT BL MOTOR XPT



Cordless Hammer Driver Drill HP332D

12V max



No load speed	High: 0 - 1,500 min ⁻¹ / Low: 0 - 450 min ⁻¹
Impacts per minute	High: 0 - 22,500 min ⁻¹ Low: 0 - 6,750 min ⁻¹
Max torque	38 N·m (340 in.lbs.)
Max fastening torque	Hard: 35 N·m (310 in.lbs.) Soft: 21 N·m (190 in.lbs.)
Capacity	Wood (Self-feed bit): 56 mm (2-3/16") Masonry: 8 mm (5/16") Wood: 28 mm (1-1/8")
Chuck capacity	0.8 - 10 mm (1/32 - 3/8")
Dimensions (L x W x H)	168 x 66 x 217 mm (6-5/8 x 2-5/8 x 8-1/2")
Net weight	1.1 - 1.3 kg (2.4 - 2.8 lbs.)

CXT BL MOTOR XPT



Cordless Driver Drill DF333D

12V max



No load speed	High: 0 - 1,700 min ⁻¹ Low: 0 - 450 min ⁻¹
Max torque	34 N·m (300 in.lbs.)
Max fastening torque	Hard: 30 N·m (270 in.lbs.) Soft: 14 N·m (130 in.lbs.)
Capacity	Wood (Self-feed bit): 42 mm (1-5/8") Steel: 10 mm (3/8") Wood: 21 mm (13/16")
Chuck capacity	0.8 - 10 mm (1/32 - 3/8")
Dimensions (L x W x H)	w/ BL1041B: 179 x 66 x 229 mm (7 x 2-5/8 x 9")
Net weight	1.1 - 1.2 kg (2.4 - 2.7 lbs.)

CXT



Cordless Hammer Driver Drill HP333D

12V max



No load speed	High: 0 - 1,700 min ⁻¹ / Low: 0 - 450 min ⁻¹
Impacts per minute	High: 0 - 25,500 min ⁻¹ Low: 0 - 6,750 min ⁻¹
Max torque	34 N·m (300 in.lbs.)
Max fastening torque	Hard: 30 N·m (270 in.lbs.) Soft: 14 N·m (130 in.lbs.)
Capacity	Wood (Self-feed bit): 42 mm (1-5/8") Steel: 10 mm (3/8") Masonry: 8 mm (5/16") Wood: 21 mm (13/16")
Chuck capacity	0.8 - 10 mm (1/32 - 3/8")
Dimensions (L x W x H)	w/ BL1041B: 193 x 66 x 229 mm (7-5/8 x 2-5/8 x 9")
Net weight	1.1 - 1.3 kg (2.4 - 2.9 lbs.)

CXT



Cordless Driver Drill DF033D

12V max



No load speed	High: 0 - 1,700 min ⁻¹ Low: 0 - 450 min ⁻¹
Max torque	34 N·m (300 in.lbs.)
Max fastening torque	Hard: 30 N·m (270 in.lbs.) Soft: 14 N·m (130 in.lbs.)
Capacity	Wood (Self-feed bit): 42 mm (1-5/8") Steel: 10 mm (3/8") Wood: 21 mm (13/16")
Chuck capacity	6.35 mm (1/4")
Dimensions (L x W x H)	w/ BL1041B: 149 x 66 x 229 mm (5-7/8 x 2-5/8 x 9")
Net weight	0.9 - 1.1 kg (2.1 - 2.4 lbs.)

CXT



Cordless Driver Drill DF030D

10.8V



No load speed	High: 0 - 1,300 min ⁻¹ Low: 0 - 350 min ⁻¹
Max torque	28 N·m (250 in.lbs.)
Max fastening torque	Hard: 24 N·m (210 in.lbs.) Soft: 14 N·m (120 in.lbs.)
Capacity	Wood (Self-feed bit): 42 mm (1-5/8") Steel: 10 mm (3/8") Wood: 21 mm (13/16")
Chuck capacity	6.35 mm (1/4")
Dimensions (L x W x H)	157 x 53 x 183 mm (6-3/16 x 2-1/16 x 7-1/4")
Net weight	0.89 kg (2 lbs.)



Screwing/Drilling

Cordless Driver Drill
DF330D

10.8V



No load speed	High: 0 - 1,300 min ⁻¹ Low: 0 - 350 min ⁻¹
Max torque	28 N·m (250 in.lbs.)
Max fastening torque	Hard: 24 N·m (210 in.lbs.) Soft: 14 N·m (120 in.lbs.)
Capacity	Wood (Self-feed bit): 42 mm (1-5/8") Steel: 10 mm (3/8") Wood: 21 mm (13/16")
Chuck capacity	0.8 - 10 mm (1/32 - 3/8")
Dimensions (L x W x H)	189 x 53 x 183 mm (7-7/16 x 2-1/16 x 7-1/4")
Net weight	1 kg (2.2 lbs.)

Cordless Hammer Driver Drill
HP330D

10.8V



No load speed	High: 0 - 1,500 min ⁻¹ Low: 0 - 400 min ⁻¹
Impacts per minute	High: 0 - 22,500 min ⁻¹ Low: 0 - 6,000 min ⁻¹
Max torque	28 N·m (250 in.lbs.)
Max fastening torque	Hard: 24 N·m (210 in.lbs.) Soft: 12 N·m (110 in.lbs.)
Capacity	Wood (Self-feed bit): 42 mm (1-5/8") Steel: 10 mm (3/8") Masonry: 8 mm (5/16") Wood: 21 mm (13/16")
Chuck capacity	0.8 - 10 mm (1/32 - 3/8")
Dimensions (L x W x H)	201 x 53 x 183 mm (7-7/8 x 2-1/16 x 7-1/4")
Net weight	1.1 kg (2.3 lbs.)

Cordless Driver Drill
DF012D

7.2V



No load speed	High: 650 min ⁻¹ Low: 200 min ⁻¹
Max torque	11 N·m (97 in.lbs.)
Max fastening torque	Hard: 5.6 N·m (50 in.lbs.) Soft: 3.6 N·m (32 in.lbs.)
Capacity	Wood (Self-feed bit): 12 mm (15/32") Steel: 5 mm (3/16") Wood: 6 mm (1/4")
Chuck capacity	6.35 mm (1/4")
Dimensions (L x W x H)	Pistol Style: 218 x 44 x 142 mm (8-5/8 x 1-3/4 x 5-5/8")
Dimensions (L x W)	Straight style: 273 x 44 mm (10-3/4 x 1-3/4")
Net weight	0.53 kg (1.2 lbs.)

In-Line Cordless Screwdriver
DF001D

3.6V



No load speed	220 min ⁻¹
Max torque	9 N·m (80 in.lbs.)
Max fastening torque	Hard / Soft: 4.0 / 3.0 N·m (35 / 27 in.lbs.)
Fastening capacities	Wood screw: Dia. 3.8 x 32 mm (1/8 x 1-1/4") Straight style: 287 x 47 x 51 mm (11-1/4 x 1-7/8 x 2") Pistol style: 205 x 47 x 51 mm (8-1/8 x 1-7/8 x 2")
Dimensions (L x W x H)	
Net weight	0.36 kg (0.79 lbs.)

Cordless Driver Drill
DF488D

18V



No load speed	High: 0 - 1,400 min ⁻¹ Low: 0 - 400 min ⁻¹
Max torque	47 N·m (420 in.lbs.)
Max fastening torque	Hard: 42 N·m (370 in.lbs.) Soft: 24 N·m (210 in.lbs.)
Capacity	Steel: 13 mm (1/2") Wood: 36 mm (1-7/16")
Chuck capacity	1.5 - 13 mm (1/16 - 1/2")
Dimensions (L x W x H)	w/ BL1815G: 221 x 83 x 240 mm (8-3/4 x 3-1/4 x 9-1/2")
Net weight	1.7 kg (3.7 lbs.)

Cordless Hammer Driver Drill
HP488D

18V



No load speed	High: 0 - 1,400 min ⁻¹ Low: 0 - 400 min ⁻¹
Impacts per minute	High: 0 - 21,000 min ⁻¹ Low: 0 - 6,000 min ⁻¹
Max torque	47 N·m (420 in.lbs.)
Max fastening torque	Hard: 42 N·m (370 in.lbs.) Soft: 24 N·m (210 in.lbs.)
Capacity	Steel: 13 mm (1/2") Masonry: 13 mm (1/2") Wood: 36 mm (1-7/16")
Chuck capacity	1.5 - 13 mm (1/16 - 1/2")
Dimensions (L x W x H)	w/ BL1815G: 239 x 83 x 240 mm (9-3/8 x 3-1/4 x 9-1/2")
Net weight	1.8 kg (4.0 lbs.)

Cordless Driver Drill
DF347D

14.4V



Max torque	34 N·m (300 in.lbs.)
Max fastening torque	Hard: 30 N·m Soft: 15 N·m
Capacity	Steel: 10 mm (3/8") Wood: 25 mm (1")
Chuck capacity	10 mm (3/8")
Dimensions (L x W x H)	198 x 83 x 235 mm (7-3/4 x 3-1/4 x 9-1/4")
Net weight	1.4 kg (3.2 lbs.)

LXT

Cordless Hammer Driver Drill
HP347D

14.4V



No load speed	High: 0 - 1,400 min ⁻¹ Low: 0 - 400 min ⁻¹
Impacts per minute	High: 0 - 21,000 min ⁻¹ Low: 0 - 6,000 min ⁻¹
Max torque	34 N·m (300 in.lbs.)
Max fastening torque	Hard: 30 N·m (270 in.lbs.) Soft: 15 N·m (130 in.lbs.)
Capacity	Wood (Self-feed bit): 50 mm (2") Steel: 10 mm (3/8") Masonry: 10 mm (3/8") Wood: 25 mm (1")
Chuck capacity	0.8 - 10 mm (1/32 - 3/8")
Dimensions (L x W x H)	216 x 83 x 235 mm (8-1/2 x 3-1/4 x 9-1/4")
Net weight	1.4 kg (3.1 lbs.)

Driver Drill
DF0300

Continuous rating Input	320W
No load speed	High: 0 - 1,500 min ⁻¹ Low: 0 - 450 min ⁻¹
Max torque	74 N·m (650 in.lbs.)
Max fastening torque	Hard / Soft: 56.0 / 21.0 N·m (500 / 190 in.lbs.)
Capacity	Steel: 10 mm (3/8") Wood: 28 mm (1-1/8")
Chuck capacity	1.0 - 10 mm (1/32 - 3/8")
Dimensions (L x W x H)	220 x 67 x 206 mm (8-5/8 x 2-5/8 x 8-1/8")
Net weight	1.2 kg (2.7 lbs.)

Hammer Driver Drill
HP0300

Continuous rating Input	320W
No load speed	High: 0 - 1,500 min ⁻¹ Low: 0 - 450 min ⁻¹
Blows per minute	High: 0 - 22,500 min ⁻¹ Low: 0 - 6,750 min ⁻¹
Max torque	74 N·m (650 in.lbs.)
Max fastening torque	Hard / Soft: 56.0 / 21.0 N·m (500 / 190 in.lbs.)
Capacity	Concrete: 8 mm (5/16") Steel: 10 mm (3/8") Wood: 28 mm (1-1/8")
Chuck capacity	1.0 - 10 mm (1/32 - 3/8")
Dimensions (L x W x H)	235 x 67 x 206 mm (9-1/4 x 2-5/8 x 8-1/8")
Net weight	1.3 kg (2.8 lbs.)

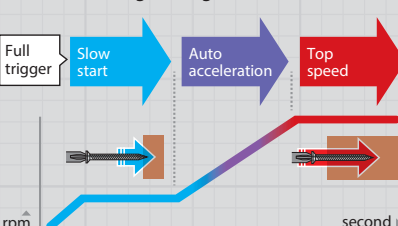

XGT	LXT	High
<div style="border: 1px solid #ccc; padding: 5px;"> <p>40V max BL MOTOR 230 N-m</p> <p>TD004G</p> <p>XGT XPT</p> <p>4 stage power selection + 1 Assist mode (1 Teks)</p> </div>		
<div style="border: 1px solid #ccc; padding: 5px;"> <p>40V max BL MOTOR 220 N-m</p> <p>TD001G TD002G</p> <p>XGT XPT</p> <p>4 stage power selection + 6 Assist mode (Wood/3 Bolt/2 Teks)</p> </div>		
<div style="border: 1px solid #ccc; padding: 5px;"> <p>40V max BL MOTOR 210 N-m</p> <p>TD003G</p> <p>XGT XPT</p> <p>4 stage power selection + 1 Assist mode (1 Teks)</p> </div>		
<div style="border: 1px solid #ccc; padding: 10px;"> <p> Assist mode</p> <p>helps to eliminate "screw cam-out" and "cross threading" by driving at low speed until the start of tightening.</p> <div style="display: flex; align-items: center; margin-top: 10px;"> <div style="text-align: center; margin-right: 10px;"> <p>Full trigger</p> <p>Slow start</p> <p>Auto acceleration</p> <p>Top speed</p> </div>  </div> </div>	<div style="border: 1px solid #ccc; padding: 5px;"> <p>18V BL MOTOR 180 N-m</p> <p>DTD173</p> <p>LXT XPT</p> <p>4 stage power selection + 4 Assist mode (Wood/Bolt/2 Teks)</p> </div>	<div style="border: 1px solid #ccc; padding: 5px;"> <p>18V BL MOTOR 175 N-m</p> <p>DTD154</p> <p>LXT XPT</p> <p>3 stage power selection + Teks mode</p> </div>
	<div style="border: 1px solid #ccc; padding: 5px;"> <p>18V BL MOTOR 170 N-m</p> <p>DTD153</p> <p>LXT XPT</p> </div>	<div style="border: 1px solid #ccc; padding: 5px;"> <p>18V BL MOTOR 165 N-m</p> <p>DTD152</p> <p>LXT XPT</p> <p>Brushed Motor</p> </div>
	<div style="border: 1px solid #ccc; padding: 5px;"> <p>18V BL MOTOR 155 N-m</p> <p>DTD156</p> <p>LXT</p> <p>Brushed Motor</p> </div>	<div style="border: 1px solid #ccc; padding: 5px;"> <p>18V BL MOTOR 140 N-m</p> <p>DTD157</p> <p>LXT XPT</p> <p>2 stage power selection + Assist mode</p> </div>
Max Fastening Torque (N-m)		

Cordless Oil-Pulse Driver

18V **40 N-m**

DTS141

LXT BL XPT

3 stage power selection + Teks mode

SOFT IMPACT

Low Noise 77dB

Suitable for noise sensitive job site

Cordless 4 Mode Impact Driver

18V **150 N-m**

DTP141

LXT BL

3 stage power selection + Teks mode



4 Operation modes

- Impact driver
- Hammer drill
- Drill
- Screwdriver

Screwing/Drilling

Cordless Impact Driver
TD004G

40V max

new



Max fastening torque	230 N·m (2,040 in.lbs.)
No load speed	Max / Hard / Med. / Soft: 0 - 3,900 / 0 - 3,000 / 0 - 2,100 / 0 - 1,200 min ⁻¹
Impacts per minute	Max / Hard / Med. / Soft: 0 - 3,900 / 0 - 3,600 / 0 - 3,100 / 0 - 1,900 min ⁻¹
Dimensions (L x W x H)	136 x 86 x 248 mm (5-3/8 x 3-3/8 x 9-3/4")
Net weight	4.0 - 3.1 kg (4.0 - 3.1 lbs.)

XGT BL MOTOR XPT

Cordless Impact Driver
TD002G

40V max



Capacity	Machine screw: M4 - M8 (5/32 - 5/16") Coarse thread (in length): 22 - 125 mm (7/8 - 4-7/8")
Max fastening torque	220 N·m (1,950 in.lbs.)
Fastening torque	Hard / Med. / Soft: 170 / 50 / 20 N·m (1,510 / 440 / 180 in.lbs.)
No load speed	Max / Hard / Med. / Soft / Wood / Bolt (1) / Bolt (2) / Bolt (3) / T (1) / T (2) mode: 0 - 3,700 / 0 - 3,200 / 0 - 2,100 / 0 - 1,100 / 0 - 1,800 / 0 - 2,700 / 0 - 3,700 / 0 - 3,700 / 0 - 2,900 / 0 - 3,700 min ⁻¹
Impacts per minute	Max / Hard / Med. / Soft / Wood / Bolt (2) / Bolt (3) / T (2) mode: 0 - 4,600 / 0 - 3,600 / 0 - 2,600 / 0 - 2,600 / 0 - 1,400 / 0 - 4,600 / 0 - 4,600 / 0 - 4,600 / 0 - 2,600 min ⁻¹
Dimensions (L x W x H)	w/ BL4080F: 119 x 86 x 297 mm (4-11/16 x 3-3/8 x 11-3/4")
Net weight	1.7 - 2.9 kg (2.9 - 6.4 lbs.)

XGT BL MOTOR XPT

Cordless Impact Driver
TD001G

40V max



Capacity	Machine screw: M4 - M8 (5/32 - 5/16") Coarse thread (in length): 22 - 125 mm (7/8 - 4-7/8")
Max fastening torque	220 N·m (1,950 in.lbs.)
Fastening torque	Hard / Med. / Soft: 170 / 50 / 20 N·m (1,510 / 440 / 180 in.lbs.)
No load speed	Max / Hard / Med. / Soft / Wood / Bolt (1) / Bolt (2) / Bolt (3) / T (1) / T (2) mode: 0 - 3,700 / 3,200 / 2,100 / 1,100 / 1,800 / 2,500 / 3,700 / 3,700 / 2,400 / 3,700 min ⁻¹
Impacts per minute	Max / Hard / Med. / Soft / Wood / Bolt (2) / Bolt (3) / T (2) mode: 0 - 4,400 / 3,600 / 2,600 / 1,100 / 4,400 / 4,400 / 4,400 / 2,600 min ⁻¹
Dimensions (L x W x H)	w/ BL4040: 120 x 86 x 250 mm (4-3/4 x 3-3/8 x 9-7/8")
Net weight	1.7 - 2.0 kg (3.7 - 4.4 lbs.)

XGT BL MOTOR XPT

Cordless Impact Driver
TD003G

40V max



Capacity	Machine screw: M4 - M8 (5/32 - 5/16") Coarse thread (in length): 22 - 125 mm (7/8 - 4-7/8")
Max fastening torque	210 N·m (1,860 in.lbs.)
Fastening torque	Hard / Med. / Soft: 170 / 50 / 20 N·m (1,510 / 440 / 180 in.lbs.)
No load speed	Max / Hard / Med. / Soft / T mode: 0 - 3,700 / 0 - 3,200 / 0 - 2,100 / 0 - 1,100 / 0 - 2,400 min ⁻¹
Impacts per minute	Max / Hard / Med. / Soft: 0 - 4,100 / 0 - 3,600 / 0 - 2,600 / 0 - 1,400 min ⁻¹
Dimensions (L x W x H)	w/ BL4080F: 121 x 86 x 293 mm (4-3/4 x 3-3/8 x 11-1/2")
Net weight	1.7 - 2.9 kg (2.9 - 6.4 lbs.)

XGT BL MOTOR XPT

Cordless Impact Driver
DTD173

18V

new



Capacity	Machine screw: M4 - M8 (5/32 - 5/16") Coarse thread (in length): 22 - 125 mm (7/8 - 4-7/8")
Max fastening torque	180 N·m (1,590 in.lbs.)
Fastening torque	Hard / Med. / Soft: 170 / 50 / 20 N·m (1,510 / 440 / 180 in.lbs.)
No load speed	Max / Hard / Med. / Soft: 0 - 3,600 / 0 - 3,200 / 0 - 2,100 / 0 - 1,100 min ⁻¹
Impacts per minute	Max / Hard / Med. / Soft: 0 - 3,800 / 0 - 3,600 / 0 - 2,600 / 0 - 1,100 min ⁻¹
Dimensions (L x W x H)	111 x 81 x 234 mm (4-3/8 x 3-1/8 x 9-1/4")
Net weight	1.5 kg (3.3 lbs.)

LXI BL MOTOR XPT

Cordless Impact Driver
DTD154

18V



Capacity	Machine screw: M4 - M8 (5/32 - 5/16") Coarse thread (in length): 22 - 125 mm (7/8 - 4-7/8")
Max fastening torque	175 N·m (1,550 in.lbs.)
No load speed	Hard / Med. / Soft: 0 - 3,600 / 0 - 2,100 / 0 - 1,100 min ⁻¹
Impacts per minute	Hard / Med. / Soft: 0 - 3,800 / 0 - 2,600 / 0 - 1,100 min ⁻¹
Dimensions (L x W x H)	117 x 79 x 236 mm (4-5/8 x 3-1/8 x 9-1/4")
Net weight	1.3 - 1.6 kg (2.7 - 3.4 lbs.)

LXI BL MOTOR XPT

Cordless Impact Driver
DTD153

18V



Capacity	Machine screw: M4 - M8 (5/32 - 5/16") Coarse thread (in length): 22 - 125 mm (7/8 - 4-7/8")
Max fastening torque	170 N·m (1,500 in.lbs.)
No load speed	0 - 3,400 min ⁻¹
Impacts per minute	0 - 3,600 min ⁻¹
Dimensions (L x W x H)	126 x 79 x 238 mm (5 x 3-1/8 x 9-3/8")
Net weight	1.3 - 1.6 kg (2.8 - 3.5 lbs.)

LXI BL MOTOR XPT

Cordless Impact Driver
DTD152

18V



Capacity	Machine screw: M4 - M8 (5/32 - 5/16") Coarse thread (in length): 22 - 125 mm (7/8 - 4-7/8")
Max fastening torque	165 N·m (1,460 in.lbs.)
No load speed	0 - 2,900 min ⁻¹
Impacts per minute	0 - 3,500 min ⁻¹
Dimensions (L x W x H)	137 x 79 x 238 mm (5-3/8 x 3-1/8 x 9-3/8")
Net weight	1.3 - 1.6 kg (2.8 - 3.5 lbs.)

LXI XPT

Cordless Impact Driver
DTD156

18V



Capacity	Machine screw: M4 - M8 (5/32 - 5/16") Coarse thread (in length): 22 - 125 mm (7/8 - 4-7/8")
Max fastening torque	155 N·m (1,370 in.lbs.)
No load speed	0 - 2,500 min ⁻¹
Impacts per minute	0 - 3,000 min ⁻¹
Dimensions (L x W x H)	w/ BL1830B / BL1840B / BL1850B / BL1860B: 143 x 79 x 241 mm (5-5/8 x 3-1/8 x 9-1/2")
Net weight	1.3 - 1.6 kg (2.9 - 3.6 lbs.)

LXI

Cordless Impact Driver
DTD157

18V



Capacity	Machine screw: M4 - M8 mm (5/32 - 5/16") Coarse thread (in length): 22 - 90 mm (7/8 - 3-1/2")
Max fastening torque	140 N·m (1,240 in.lbs.)
No load speed	Hard / Soft: 0 - 3,000 / 0 - 1,300 min ⁻¹
Impacts per minute	Hard / Soft: 0 - 4,100 / 0 - 2,000 min ⁻¹
Dimensions (L x W x H)	w/ BL1830B / BL1840B / BL1850B / BL1860B: 133 x 81 x 232 mm (5-1/4 x 3-1/8 x 9-1/8")
Net weight	1.2 - 1.5 kg (2.6 - 3.3 lbs.)

LXI BL MOTOR XPT



Cordless Impact Driver TD111D

12V max



Capacity	Machine screw: M4 - M8 mm (5/32 - 5/16") Coarse thread (in length): 22 - 90 mm (7/8 - 3-1/2")
Max fastening torque	135 N-m (1,200 in.lbs.)
No load speed	Hard / Soft: 0 - 3,000 / 0 - 1,300 min ⁻¹
Impacts per minute	Hard / Soft: 0 - 3,900 / 0 - 1,600 min ⁻¹
Dimensions (L x W x H)	135 x 66 x 210 mm (5-5/16 x 2-5/8 x 8-1/4")
Net weight	0.97 - 1.1 kg (2.1 - 2.5 lbs.)



Cordless Impact Driver TD110D

12V max



Capacity	Machine screw: M4 - M8 mm (5/32 - 5/16") Coarse thread (in length): 22 - 90 mm (7/8 - 3-1/2")
Max fastening torque	110 N-m (970 in.lbs.)
No load speed	0 - 2,600 min ⁻¹
Impacts per minute	0 - 3,500 min ⁻¹
Dimensions (L x W x H)	153 x 66 x 204 mm (6 x 2-5/8 x 8-1/8")
Net weight	1 - 1.2 kg (2.3 - 2.6 lbs.)



Cordless Impact Driver TD090D

10.8V



Capacity	Machine screw: M4 - M8 mm (5/32 - 5/16") Coarse thread (in length): 22 - 90 mm (7/8 - 3-1/2")
Max fastening torque	90 N-m (800 in.lbs.)
No load speed	0 - 2,400 min ⁻¹
Impacts per minute	0 - 3,000 min ⁻¹
Dimensions (L x W x H)	155 x 54 x 178 mm (6-1/8 x 2-1/8 x 7")
Net weight	0.92 kg (2 lbs.)



Cordless Impact Driver TD022D

7.2V



Capacity	Machine screw: M3 - M8 (1/8 - 5/16") Coarse thread (in length): 22 - 45 mm (7/8 - 1-3/4")
Max fastening torque	25 N-m (220 in.lbs.)
No load speed	0 - 2,450 min ⁻¹
Impacts per minute	0 - 3,000 min ⁻¹
Dimensions (L x W x H)	Straight style: 282 x 42 x 52 mm (11-1/8 x 1-5/8 x 2-1/16") Pistol Style: 227 x 42 x 142 mm (8-15/16 x 1-5/8 x 5-5/8")
Net weight	0.55 - 0.56 kg (1.2 lbs.)



Cordless Impact Driver TD127D

18V



Capacity	Machine screw: M4 - M8 (5/32 - 5/16") Coarse thread (in length): 22 - 125 mm (7/8 - 4-7/8")
Max fastening torque	140 N-m (1,240 in.lbs.)
No load speed	0 - 2,300 min ⁻¹
Impacts per minute	0 - 3,000 min ⁻¹
Dimensions (L x W x H)	173 x 82 x 225 mm (6-13/16 x 3-1/4 x 8-7/8")
Net weight	1.5 kg (3.2 lbs.)



Impact Driver 6952



Continuous rating Input	270W
Capacity	Machine screw: M4 - M10 (5/32 - 3/8")
Driving shank (Hex)	6.35 mm (1/4")
Max fastening torque	120 N-m (88.5 ft.lbs.)
No load speed	0 - 3,200 min ⁻¹
Impacts per minute	0 - 3,100 min ⁻¹
Overall length	229 mm (9")
Net weight	1.4 kg (3.1 lbs.)



Impact Driver TD0100



Continuous rating Input	230W
Capacity	Machine screw: M4 - M8 (5/32 - 5/16") Coarse thread (in length): 22 - 90 mm (7/8 - 3-1/2")
Driving shank (Hex)	6.35 mm (1/4")
Max fastening torque	100 N-m (74 ft.lbs.)
No load speed	0 - 3,600 min ⁻¹
Impacts per minute	0 - 3,200 min ⁻¹
Dimensions (L x W x H)	218 x 60 x 180 mm (8-5/8 x 2-3/8 x 7-1/8")
Net weight	0.96 kg (2.1 lbs.)



Impact Driver TD0101F



Continuous rating Input	230W
Capacity	Machine screw: M4 - M8 (5/32 - 5/16") Coarse thread (in length): 22 - 90 mm (7/8 - 3-1/2")
Driving shank (Hex)	6.35 mm (1/4")
Max fastening torque	100 N-m (74 ft.lbs.)
No load speed	0 - 3,600 min ⁻¹
Impacts per minute	0 - 3,200 min ⁻¹
Dimensions (L x W x H)	184 x 67 x 192 mm (7-1/4 x 2-5/8 x 7-9/16")
Net weight	0.99 kg (2.2 lbs.)



Impact Driver TD0101



Continuous rating Input	230W
Capacity	Machine screw: M4 - M8 (5/32 - 5/16") Coarse thread (in length): 22 - 90 mm (7/8 - 3-1/2")
Driving shank (Hex)	6.35 mm (1/4")
Max fastening torque	100 N-m (74 ft.lbs.)
No load speed	0 - 3,600 min ⁻¹
Impacts per minute	0 - 3,200 min ⁻¹
Dimensions (L x W x H)	184 x 67 x 192 mm (7-1/4 x 2-5/8 x 7-9/16")
Net weight	0.99 kg (2.2 lbs.)



Cordless Angle Impact Driver DTL061

18V



Capacity	Machine screw: M4 - M8 (5/32 - 5/16") Standard bolt: M4 - M12 (5/32 - 1/2") High strength bolt: M4 - M8 (5/32 - 5/16")
Hex shank	6.35 mm (1/4")
Max fastening torque	60 N-m (530 in.lbs.)
No load speed	0 - 2,000 min ⁻¹
Impacts per minute	0 - 3,000 min ⁻¹
Dimensions (L x W x H)	387 x 78 x 116 mm (15-1/4 x 3-1/16 x 4-9/16")
Net weight	1.4 - 2 kg (3.1 - 4.3 lbs.)



Screwing/Drilling

Cordless Angle Impact Driver
TL064D

12V max



Capacity	Machine screw: M4 - M8 (5/32 - 5/16") Standard bolt: M4 - M12 (5/32 - 1/2") High strength bolt: M4 - M8 (5/32 - 5/16")
Hex shank	6.35 mm (1/4")
Max fastening torque	60 N·m (530 in.lbs.)
No load speed	0 - 2,000 min ⁻¹
Impacts per minute	0 - 3,000 min ⁻¹
Dimensions (L x W x H)	361 x 66 x 86 mm (14-1/4 x 2-5/8 x 3-3/8")
Net weight	1.2 - 1.6 kg (2.7 - 3.6 lbs.)

Cordless 4 Mode Impact Driver
DTP141

18V



Capacity	Steel: 10 mm (3/8") Wood: 21 mm (13/16") Masonry: 8 mm (5/16")
Max fastening torque	Impact-driver mode: 150 N·m (1,330 in.lbs.) Drill mode (Hard / Soft): 22 / 13 N·m
No load speed	Impact-driver mode (Hard / Med. / Soft): 0 - 2,700 / 0 - 2,200 / 0 - 1,300 min ⁻¹ Drill mode (Hi / Lo): 0 - 2,700 / 0 - 700 min ⁻¹
Impacts per minute	0 - 3,200 / 0 - 2,400 / 0 - 1,200 min ⁻¹
Dimensions (L x W x H)	171 x 79 x 250 mm (6-3/4 x 3-1/8 x 9-7/8")
Net weight	1.5 - 1.9 kg (3.4 - 4.1 lbs.)

Cordless Oil-Pulse Driver
DTS141

18V



Capacity	Machine screw: M4 - M8 (5/32 - 5/16") Standard bolt: M5 - M8 (3/16 - 5/16") High strength bolt: M5 - M6 (3/16 - 1/4") Coarse thread (in length): 22 - 125 mm (7/8 - 4-7/8")
Max fastening torque	40 N·m (355 in.lbs.)
No load speed	Hard: 0 - 3,200 min ⁻¹ Med.: 0 - 2,000 min ⁻¹ / Soft: 0 - 1,200 min ⁻¹
Impacts per minute	Hard: 0 - 2,700 min ⁻¹ Med.: 0 - 2,200 min ⁻¹ Soft: 0 - 1,400 min ⁻¹
Dimensions (L x W x H)	136 x 79 x 240 mm (5-3/8 x 3-1/8 x 9-1/2")
Net weight	1.3 - 1.6 kg (2.8 - 3.5 lbs.)

2-Speed Drill
DP4011

Continuous rating	720W
Input	
Capacity	Steel Hi: 8 mm (5/16") Steel Lo: 13 mm (1/2") Wood Hi: 25 mm (1") Wood Lo: 40 mm (1-9/16") Wood (Self-feed bit): 90 mm (90°)
No Load Speed	High: 0 - 2,900 min ⁻¹ Low: 0 - 1,200 min ⁻¹
Chuck capacity	1.5 - 13 mm (1/16 - 1/2")
Dimensions (L x W x H)	347 x 70 x 220 mm (13-5/8 x 2-3/4 x 8-5/8")
Net weight	2.3 kg (5 lbs.)

2-Speed Drill
DP4010

Continuous rating	720W
Input	
Capacity	Steel Hi: 8 mm (5/16") Steel Lo: 13 mm (1/2") Wood Hi: 25 mm (1") Wood Lo: 40 mm (1-9/16") Wood (Self-feed bit): 90 mm (3-1/2")
No Load Speed	High: 0 - 2,900 min ⁻¹ Low: 0 - 1,200 min ⁻¹
Chuck capacity	1.5 - 13 mm (1/16 - 1/2")
Dimensions (L x W x H)	347 x 70 x 220 mm (13-5/8 x 2-3/4 x 8-5/8")
Net weight	2.3 kg (5 lbs.)

Drill
DS5000

Continuous rating	750W
Input	
Capacity	Steel: 16 mm (5/8") Wood: 36 mm (1-7/16") Wood (Self-feed bit): 127 mm (5")
No load speed	600 min ⁻¹
Chuck capacity	3 - 16 mm (1/8 - 5/8")
Dimensions (L x W x H)	348 x 83 x 401 mm (13-3/4 x 3-1/4 x 15-3/4")
Net weight	3 kg (6.6 lbs.)

Drill
6305

Continuous rating	850W
Input	
Capacity	Steel: 13 mm (1/2") Wood: 30 mm (1-3/16") Wood (Self-feed bit): 60 mm (2-3/8")
No load speed	1,450 min ⁻¹
Chuck capacity	2 - 13 mm (1/16 - 1/2")
Dimensions (L x W x H)	346 x 84 x 152 mm (13-5/8 x 3-5/16 x 6")
Net weight	2.8 kg (6.2 lbs.)

Drill
DS4012

Continuous rating	750W
Input	
Capacity	Steel: 13 mm (1/2") Wood: 36 mm (1-7/16") Wood (Self-feed bit): 127 mm (5")
No load speed	0 - 600 min ⁻¹
Chuck capacity	2 - 13 mm (1/16 - 1/2")
Dimensions (L x W x H)	340 x 83 x 390 mm (13-3/8 x 3-1/4 x 15-3/8")
Net weight	2.8 kg (6.2 lbs.)

Drill
DS4011

Continuous rating	750W
Input	
Capacity	Steel: 13 mm (1/2") Wood: 36 mm (1-7/16") Wood (Self-feed bit): 127 mm (5")
No load speed	600 min ⁻¹
Chuck capacity	2 - 13 mm (1/16 - 1/2")
Dimensions (L x W x H)	340 x 83 x 401 mm (13-3/8 x 3-1/4 x 15-3/4")
Net weight	2.8 kg (6.3 lbs.)

Drill
DP4003

Continuous rating	750W
Input	
Capacity	Steel: 13 mm (1/2") Wood: 38 mm (1-1/2") Wood (Self-feed bit): 76 mm (3")
No load speed	0 - 700 min ⁻¹
Chuck capacity	1.5 - 13 mm (1/16 - 1/2")
Overall length	308 mm (12-1/8")
Net weight	2.5 kg (5.4 lbs.)



Screwing/Drilling

Drill DP4001



Continuous rating	750W
Input	
Capacity	Steel: 13 mm (1/2") Wood: 38 mm (1-1/2") Wood (Self-feed bit): 76 mm (3")
No load speed	0 - 950 min ⁻¹
Chuck capacity	1.5 - 13 mm (1/16 - 1/2")
Overall length	308 mm (12-1/8")
Net weight	2.4 kg (5.2 lbs.)



Drill DP4000



Continuous rating	750W
Input	
Capacity	Steel: 13 mm (1/2") Wood: 38 mm (1-1/2") Wood (Self-feed bit): 76 mm (3")
No load speed	0 - 950 min ⁻¹
Chuck capacity	2 - 13 mm (1/16 - 1/2")
Overall length	304 mm (12")
Net weight	2.5 kg (5.6 lbs.)



Drill DP4002



Continuous rating	750W
Input	
Capacity	Steel: 13 mm (1/2") Wood: 38 mm (1-1/2") Wood (Self-feed bit): 76 mm (3")
No load speed	0 - 700 min ⁻¹
Chuck capacity	2 - 13 mm (1/16 - 1/2")
Overall length	304 mm (12")
Net weight	2.7 kg (5.8 lbs.)



Drill DP4021

new



Continuous rating	630W
Input	
Capacity	Steel: 13 mm (1/2") Wood: 30 mm (1-3/16")
No load speed	0 - 3,000 min ⁻¹
Chuck capacity	1.5 - 13 mm (1/16 - 1/2")
Dimensions (L x W x H)	271 x 66 x 209 mm (10-5/8 x 2-5/8 x 8-1/4")
Net weight	1.6 kg (3.5 lbs.)



Drill DP4020

new



Continuous rating	630W
Input	
Capacity	Steel: 13 mm (1/2") Wood: 30 mm (1-3/16")
No load speed	0 - 3,000 min ⁻¹
Chuck capacity	1.5 - 13 mm (1/16 - 1/2")
Dimensions (L x W x H)	269 x 66 x 209 mm (10-5/8 x 2-5/8 x 8-1/4")
Net weight	1.7 kg (3.7 lbs.)



Drill 6413



Continuous rating	450W
Input	
Capacity	Steel: 10 mm (3/8") Wood: 25 mm (1") Wood (Self-feed bit): 50 mm (2")
No load speed	0 - 3,400 min ⁻¹
Chuck capacity	1.5 - 10 mm (1/16 - 3/8")
Dimensions (L x W x H)	234 x 64 x 183 mm (9-1/4 x 2-1/2 x 7-1/4")
Net weight	1.3 kg (2.9 lbs.)



Drill 6412



Continuous rating	450W
Input	
Capacity	Steel: 10 mm (3/8") Wood: 25 mm (1") Wood (Self-feed bit): 50 mm (2")
No load speed	0 - 3,400 min ⁻¹
Chuck capacity	1.5 - 10 mm (1/16 - 3/8")
Dimensions (L x W x H)	228 x 64 x 183 mm (9 x 2-1/2 x 7-1/4")
Net weight	1.3 kg (2.9 lbs.)



Drill 6411



Continuous rating	450W
Input	
Capacity	Steel: 10 mm (3/8") Wood: 25 mm (1") Wood (Self-feed bit): 50 mm (2")
No load speed	3,400 min ⁻¹
Chuck capacity	1.5 - 10 mm (1/16 - 3/8")
Dimensions (L x W x H)	228 x 64 x 183 mm (9 x 2-1/2 x 7-1/4")
Net weight	1.3 kg (2.8 lbs.)



High Speed Drill DP2011



Continuous rating	370W
Input	
Capacity	Steel: 6.5 mm (1/4") Wood: 15 mm (9/16") Wood (Self-feed bit): 30 mm (1-3/16")
No load speed	0 - 4,200 min ⁻¹
Chuck capacity	0.8 - 6.5mm (1/32 - 1/4")
Dimensions (L x W x H)	222 x 64 x 175 mm (8-3/4 x 2-1/2 x 6-7/8")
Net weight	1.1 kg (2.4 lbs.)



High Speed Drill DP2010



Continuous rating	370W
Input	
Capacity	Steel: 6.5 mm (1/4") Wood: 15 mm (9/16") Wood (Self-feed bit): 30 mm (1-3/16")
No load speed	0 - 4,200 min ⁻¹
Chuck capacity	0.5 - 6.5mm (1/64 - 1/4")
Dimensions (L x W x H)	209 x 64 x 175 mm (8-1/4 x 2-1/2 x 6-7/8")
Net weight	1 kg (2.2 lbs.)



Screwing/Drilling

High Speed Drill
DD2020

Continuous rating Input	500W
Capacity	Wood: 12 mm (1/2") Wood (Self-feed bit): 24 mm (1 5/16")
No load speed	10,000 min ⁻¹
Chuck capacity	0.5 - 6.5mm (1/64 - 1/4")
Dimensions (L x W x H)	274 x 131 x 67 mm (10-3/4 x 5-1/8 x 2-5/8")
Net weight	1.3 kg (2.9 lbs.)

Cordless Angle Drill
DA001G

40V max



Capacity	Steel: 13 mm (1/2") Wood (Self-feed bit), Hi: 65 mm (2-9/16") Wood (Self-feed bit), Lo: 118 mm (4-5/8") Wood (Hole saw), Hi: 105 mm (4-1/8") Wood (Hole saw), Lo: 159 mm (6-1/4")
Chuck capacity	2 - 13 mm (1/16 - 1/2")
No load speed	High: 0 - 1,500 min ⁻¹ Low: 0 - 400 min ⁻¹
Max torque	High: 55 N-m (487 in.lbs) Low: 136 N-m (1,210 in.lbs)
Dimensions (L x W x H)	w/ BL4050F: 566 x 128 x 199 mm (22-1/4 x 5 x 7-7/8")
Net weight	5.3 - 6.2 kg (11.7 - 13.7 lbs.)

XGT BL ADT XPT

Cordless Angle Drill
DA002G

40V max



Capacity	Steel: 13 mm (1/2") Wood (Self-feed bit), Hi: 65 mm (2-9/16") Wood (Self-feed bit), Lo: 118 mm (4-5/8") Wood (Hole saw), Hi: 105 mm (4-1/8") Wood (Hole saw), Lo: 159 mm (6-1/4")
Hex shank	11 mm (7/16")
No load speed	High: 0 - 1,500 min ⁻¹ Low: 0 - 400 min ⁻¹
Max torque	High: 55 N-m (487 in.lbs) Low: 136 N-m (1,210 in.lbs)
Dimensions (L x W x H)	w/ BL4050F: 566 x 128 x 193 mm (22-1/4 x 5 x 7-5/8")
Net weight	4.9 - 5.8 kg (10.8 - 12.8 lbs.)

XGT BL ADT XPT

Cordless Angle Drill
DDA460

18V x2



Capacity	Steel: 13 mm (1/2") Wood (Self-feed bit), Hi: 65 mm (2-9/16") Wood (Self-feed bit), Lo: 118 mm (4-5/8") Wood (Hole saw), Hi: 105 mm (4-1/8") Wood (Hole saw), Lo: 159 mm (6-1/4")
Chuck capacity	2 - 13 mm (5/64 - 1/2")
No load speed	High: 0 - 1,400 min ⁻¹ Low: 0 - 350 min ⁻¹
Max fastening torque	High: 48 N-m (430 in.lbs.) Low: 136 N-m (1,210 in.lbs.)
Dimensions (L x W x H)	538 x 128 x 223 mm (21-1/4 x 5 x 8-3/4")
Net weight	5.7 - 6.4 kg (12.6 - 14.0 lbs.)

LXI BL ADT XPT

Cordless Angle Drill
DDA450

18V



Capacity	Steel: 13 mm (1/2") Wood (Self-feed bit), Hi: 50 mm (2") Wood (Self-feed bit), Lo: 65 mm (2-9/16") Wood (Hole saw), Hi: 101 mm (4") Wood (Hole saw), Lo: 127 mm (5")
Chuck capacity	2 - 13 mm (1/16 - 1/2")
No load speed	High: 0 - 1,400 min ⁻¹ Low: 0 - 450 min ⁻¹
Max fastening torque	High: 26 N-m (230 in.lbs.) Low: 70 N-m (620 in.lbs.)
Dimensions (L x W x H)	w/ BL1830B / BL1840B / BL1850B / BL1860B: 434 x 82 x 179 mm (17-1/8 x 3-1/4 x 7")
Net weight	3.2 - 3.5 kg (7.1 - 7.7 lbs.)

LXI BL XPT

Cordless Angle Drill
DDA451

18V



Capacity	Steel: 13 mm (1/2") Wood (Self-feed bit), Hi: 50 mm (2") Wood (Self-feed bit), Lo: 65 mm (2-9/16") Wood (Hole saw), Hi: 101 mm (4") Wood (Hole saw), Lo: 127 mm (5")
Hex shank	11 mm (7/16")
No load speed	High: 0 - 1,400 min ⁻¹ Low: 0 - 450 min ⁻¹
Max fastening torque	High: 26 N-m (230 in.lbs.) Low: 70 N-m (620 in.lbs.)
Dimensions (L x W x H)	w/ BL1830B / BL1840B / BL1850B / BL1860B: 434 x 82 x 163 mm (17-1/8 x 3-1/4 x 6-3/8")
Net weight	2.8 - 3.3 kg (6.2 - 7.3 lbs.)

LXI BL XPT

Cordless Angle Drill
DDA351

18V



Capacity	Steel: 10 mm (3/8") Wood: 25 mm (1") Hole saw: 50 mm (2")
Chuck capacity	1.5 - 10 mm (1/16 - 3/8")
No load speed	0 - 1,800 min ⁻¹
Dimensions (L x W x H)	326 x 79 x 115 mm (12-7/8 x 3-1/8 x 4-1/2")
Net weight	1.6 - 1.9 kg (4.2 - 3.5 lbs.)

LXI

Cordless Angle Drill
DDA350

18V



Capacity	Steel: 10 mm (3/8") Wood: 25 mm (1") Hole saw: 50 mm (2")
Chuck capacity	1.5 - 10 mm (1/16 - 3/8")
No load speed	0 - 1,800 min ⁻¹
Dimensions (L x W x H)	314 x 79 x 115 mm (12-3/8 x 3-1/8 x 4-1/2")
Net weight	1.5 - 1.8 kg (4.1 - 3.4 lbs.)

LXI

Cordless Angle Drill
DA333D

12V max



Capacity	Steel: 10 mm (3/8") Wood: 12 mm (1/2") Hole saw: 24 mm (15/16")
Chuck capacity	0.8 - 10 mm (1/32 - 3/8")
No load speed	0 - 1,100 min ⁻¹
Dimensions (L x W x H)	w/ BL1041B: 332 x 68 x 95 mm (13-1/8 x 2-11/16 x 3-3/4")
Net weight	1.2 - 1.4 kg (2.7 - 3 lbs.)

CXT



Screwing/Drilling

Cordless Angle Drill DA332D

12V max



Capacity	Steel: 10 mm (3/8") Wood: 12 mm (1/2") Hole saw: 24 mm (15/16")
Chuck capacity	1.5 - 10 mm (1/16 - 3/8")
No load speed	0 - 1,100 min ⁻¹
Dimensions (L x W x H)	w/ BL 1041B: 332 x 68 x 86 mm (13-1/8 x 2-11/16 x 3-3/8")
Net weight	1.2 - 1.3 kg (2.6 - 2.9 lbs.)



Angle Drill DA4000LR



Continuous rating Input	710W
Capacity	Steel: 13 mm (1/2") Wood (Self-feed bit) Hi: 65 mm (2-9/16") Wood (Self-feed bit) Lo: 118 mm (4-5/8")
Chuck capacity	2 - 13 mm (1/16 - 1/2")
No load speed	High: 0 - 900 min ⁻¹ Low: 0 - 400 min ⁻¹
Overall length	413 mm (16-1/4")
Net weight	4 kg (8.9 lbs.)



Angle Drill DA4031



Continuous rating Input	1,050W
Capacity	Steel: 13 mm (1/2") Wood (Self-feed bit) Hi: 65 mm (2-9/16") Wood (Self-feed bit) Lo: 118 mm (4-5/8")
Chuck capacity	2 - 13 mm (1/16 - 1/2")
No load speed	High: 1,200 min ⁻¹ Low: 300 min ⁻¹
Overall length	462 mm (18-3/16")
Net weight	6.3 kg (13.9 lbs.)



Angle Drill DA3011F



Continuous rating Input	450W
Capacity	Steel: 10 mm (3/8") Wood: 25 mm (1")
Chuck capacity	1.5 - 10 mm (1/16 - 3/8")
No load speed	0 - 2,400 min ⁻¹
Overall length	282 mm (11-1/8")
Net weight	1.6 kg (3.5 lbs.)



Angle Drill DA3010F



Continuous rating Input	450W
Capacity	Steel: 10 mm (3/8") Wood: 25 mm (1")
Chuck capacity	1.5 - 10 mm (1/16 - 3/8")
No load speed	0 - 2,400 min ⁻¹
Overall length	270 mm (10-5/8")
Net weight	1.6 kg (3.5 lbs.)



Angle Drill DA3010



Continuous rating Input	450W
Capacity	Steel: 10 mm (3/8") Wood: 25 mm (1")
Chuck capacity	1.5 - 10 mm (1/16 - 3/8")
No load speed	0 - 2,400 min ⁻¹
Overall length	270 mm (10-5/8")
Net weight	1.6 kg (3.5 lbs.)



Magnetic Drill HB500



Capacity	Steel: 50 mm (2")
Chuck capacity	16 mm (5/8")
No load speed	350 / 650 min ⁻¹
Magnetic clamping force	9,300 N (950 kg)
Dimensions (L x W x H)	290 x 150 x 450 mm (11-3/8 x 5-7/8 x 17-3/4")
Net weight	18.5 kg (40.8 lbs.)

Magnetic Drill HB350



Continuous rating Input	1,050W
Capacity	Steel: 35 mm (1-3/8")
Chuck capacity	13 mm (1/2")
No load speed	850 min ⁻¹
Magnetic clamping force	8,000 N (816 kg)
Dimensions (L x W x H)	225 x 195 x 490 mm (8-7/8 x 7-5/8 x 19-1/4")
Net weight	11.6 kg (25.6 lbs.)



Cordless Impact Wrench



Screwing/
Drilling

High

Low

XGT

LXT

40V max **BL MOTOR** **3,150 N-m**

TW010G
XGT XPT

Square drive size **1" (25.4mm)**

- M27 - 45
- M20 - 33

40V max **BL MOTOR** **1,800 N-m**

TW001G
XGT XPT

Square drive size **3/4" (19mm)**

- M12 - 36
- M10 - 27

40V max **BL MOTOR** **1,700 N-m**

TW002G
C ring
XGT XPT

Square drive size **1/2" (12.7mm)**

- M12 - 36
- M10 - 27

40V max **BL MOTOR** **1,360 N-m**

TW003G
Pin detent
XGT XPT

Square drive size **1/2" (12.7mm)**

- M12 - 36
- M10 - 27

40V max **BL MOTOR** **760 N-m**

TW007G TW008G
C ring Pin detent
XGT XPT

Square drive size **1/2" (12.7mm)**

- M10 - 24
- M10 - 16

40V max **BL MOTOR** **350 N-m**

TW004G TW005G
C ring Pin detent
XGT XPT

Square drive size **1/2" (12.7mm)**

- M10 - 20
- M10 - 16

18V **BL MOTOR** **1,200 N-m**

DTW1002
LXT

Square drive size **1/2" (12.7mm)**

- M12 - 30
- M10 - 24

18V **BL MOTOR** **1,250 N-m**

DTW1001
LXT

Square drive size **3/4" (19mm)**

- M12 - 30
- M10 - 24

18V **BL MOTOR** **1,050 N-m**

DTW1004
LXT

Square drive size **1/2" (12.7mm)**

- M12 - 30
- M10 - 20

18V **BL MOTOR** **800 N-m**

DTW800
LXT

Hex shank size **7/16" (11.1mm)**

- M12 - 24
- M10 - 22

18V **BL MOTOR** **700 N-m**

DTW700 DTW701
C ring Pin detent
LXT XPT

Square drive size **1/2" (12.7mm)**

- M10 - 24
- M10 - 16

18V **BL MOTOR** **440 N-m**

DTW450
LXT Brushed Motor

Square drive size **1/2" (12.7mm)**

- M12 - 22
- M12 - 16

18V **BL MOTOR** **330 N-m**

DTW300 DTW301
C ring Pin detent
LXT XPT

Square drive size **1/2" (12.7mm)**

- M10 - 20
- M10 - 16

18V **BL MOTOR** **300 N-m**

DTW302
LXT XPT

Square drive size **3/8" (9.5mm)**

- M10 - 20
- M10 - 16

18V **BL MOTOR** **210 N-m**

DTW181
LXT XPT

Square drive size **1/2" (12.7mm)**

- M8 - 16
- M6 - 12

18V **BL MOTOR** **230 N-m**

DTW251
LXT Brushed Motor

Square drive size **1/2" (12.7mm)**

- M10 - 16
- M10 - 14

18V **BL MOTOR** **210 N-m**

DTW253
LXT Brushed Motor

Square drive size **3/8" (9.5mm)**

- M8 - 16
- M6 - 12

18V **BL MOTOR** **190 N-m**

DTW190
LXT Brushed Motor

Square drive size **1/2" (12.7mm)**

- M8 - 16
- M8 - 12

18V **BL MOTOR** **180 N-m**

DTW180
LXT XPT

Square drive size **3/8" (9.5mm)**

- M8 - 16
- M6 - 12

Cordless Impact Wrench TW010G

40V max

new



Square drive	25.4 mm (1")
Max fastening torque	3,150 N-m (2,323 ft.lbs.)
Nut-busting torque	4,000 N-m (2,950 ft.lbs.)
No load speed	Max / Hard / Med. / Soft: 0 - 1,200 / 0 - 850 / 0 - 700 / 0 - 600 min ⁻¹
Impacts per minute	Max / Hard / Med. / Soft: 0 - 1,750 / 0 - 1,500 / 0 - 1,300 / 0 - 1,200 min ⁻¹
Dimensions (L x W x H)	570 x 135 x 276 mm (22-1/2 x 5-5/16 x 10-7/8")
Net weight	12.0 - 12.9 kg (26.5 - 28.4 lbs.)

XGT BL MOTOR XPT



Cordless Impact Wrench TW001G

40V max



Square drive	19.0 mm (3/4")
Max fastening torque	1,800 N-m (1,330 ft.lbs.)
Fastening torque	Max / Hard / Med. / Soft: 1,800 / 1,500 / 840 / 450 N-m (1,330 / 1,110 / 620 / 330 ft.lbs.)
Fastening capacities	Standard bolt: M12 - M36 (1/2 - 1-1/2") High strength bolt: M10 - M27 (3/8 - 1-1/8")
Nut-busting torque	2,050 N-m (1,510 ft.lbs.)
No load speed	Max / Hard / Med. / Soft: 0 - 1,800 / 0 - 1,400 / 0 - 1,150 / 0 - 950 min ⁻¹
Impacts per minute	Max / Hard / Med. / Soft: 0 - 2,500 / 0 - 2,400 / 0 - 2,200 / 0 - 1,900 min ⁻¹
Dimensions (L x W x H)	217 x 94 x 297 mm (8-1/2 x 3-11/16 x 11-3/4")
Net weight	3.9 - 4.2 kg (8.6 - 9.3 lbs.)

XGT BL MOTOR XPT



Cordless Impact Wrench TW002G

40V max

new

C ring



Square drive	12.7 mm (1/2")
Max fastening torque	1,700 N-m (1,250 ft.lbs.)
Nut-busting torque	2,200 N-m (1,620 ft.lbs.)
No load speed	Max / Hard / Med. / Soft: 0 - 1,800 / 0 - 1,000 / 0 - 900 / 0 - 850 min ⁻¹
Impacts per minute	Max / Hard / Med. / Soft: 0 - 2,400 / 0 - 2,000 / 0 - 1,800 / 0 - 1,700 min ⁻¹
Dimensions (L x W x H)	213 x 94 x 297 mm (8-3/8 x 3-11/16 x 11-3/4")
Net weight	3.9 - 5.1 kg (8.6 - 11.2 lbs.)

XGT BL MOTOR XPT



Cordless Impact Wrench TW003G

40V max

new

Pin-detent



Square drive	12.7 mm (1/2")
Max fastening torque	1,360 N-m (1,000 ft.lbs.)
Nut-busting torque	1,600 N-m (1,180 ft.lbs.)
No load speed	Max / Hard / Med. / Soft: 0 - 1,800 / 0 - 1,200 / 0 - 1,000 / 0 - 800 min ⁻¹
Impacts per minute	Max / Hard / Med. / Soft: 0 - 2,400 / 0 - 2,300 / 0 - 2,000 / 0 - 1,600 min ⁻¹
Dimensions (L x W x H)	213 x 94 x 297 mm (8-3/8 x 3-11/16 x 11-3/4")
Net weight	3.8 - 5.0 kg (8.4 - 11.0 lbs.)

XGT BL MOTOR XPT



Cordless Impact Wrench TW007G / TW008G

40V max



TW007G:
C ring



TW008G:
Pin detent

Square drive	12.7 mm (1/2")
Max fastening torque	760 N-m (560 ft.lbs.)
Fastening capacities	Standard bolt: M10 - M24 (3/8 - 1") High strength bolt (Grade 10.9): M10 - M16 (3/8 - 5/8")
Nut-busting torque	1,100 N-m (810 ft.lbs.)
No load speed	Max / Hard / Med. / Soft: 0 - 2,300 / 0 - 1,900 / 0 - 1,200 / 0 - 600 min ⁻¹
Impacts per minute	Max / Hard / Med. / Soft: 0 - 2,900 / 0 - 2,700 / 0 - 1,900 / 0 - 1,200 min ⁻¹
Dimensions (L x W x H)	170 x 86 x 312 mm (6-11/16 x 3-3/8 x 12-1/4")
Net weight	2.7 - 3.3 kg (6.0 - 7.3 lbs.)

XGT BL MOTOR XPT



Cordless Impact Wrench TW004G / TW005G

40V max



TW004G:
C ring



TW005G:
Pin detent

Square drive	12.7 mm (1/2")
Max fastening torque	350 N-m (260 ft.lbs.)
Fastening capacities	Standard bolt: M10 - M20 (3/8 - 3/4") High strength bolt: M10 - M16 (3/8 - 5/8")
Nut-busting torque	630 N-m (465 ft.lbs.)
No load speed	Max / Hard / Med. / Soft: 0 - 3,200 / 0 - 2,600 / 0 - 1,800 / 0 - 1,000 min ⁻¹
Impacts per minute	Max / Hard / Med. / Soft: 0 - 4,000 / 0 - 3,400 / 0 - 2,600 / 0 - 1,800 min ⁻¹
Dimensions (L x W x H)	144 x 86 x 248 mm (5-5/8 x 3-3/8 x 9-3/4")
Net weight	1.9 - 2.2 kg (4.2 - 4.9 lbs.)

XGT BL MOTOR XPT



Cordless Impact Wrench DTW1001

18V

C ring



Square drive	19.0 mm (3/4")
Max fastening torque	1,250 N-m (920 in.lbs.)
Fastening capacities	Standard bolt: M12 - M30 (1/2 - 1-1/4") High strength bolt: M10 - M24 (3/8 - 1")
Nut-busting torque	1,700 N-m (1,250 ft.lbs.)
No load speed	Hard / Med. / Soft: 0 - 1,800 / 0 - 1,000 / 0 - 900 min ⁻¹
Impacts per minute	Hard / Med. / Soft: 0 - 2,200 / 0 - 2,000 / 0 - 1,800 min ⁻¹
Dimensions (L x W x H)	229 x 91 x 289 mm (9 x 3-5/8 x 11-3/8")
Net weight	3.4 - 3.7 kg (7.5 - 8.2 lbs.)

LXI BL MOTOR XPT



Cordless Impact Wrench DTW1002

18V

C ring



Square drive	12.7 mm (1/2")
Max fastening torque	1,200 N-m (890 in.lbs.)
Fastening capacities	Standard bolt: M12 - M30 (1/2 - 1-1/4") High strength bolt: M10 - M24 (3/8 - 1")
Nut-busting torque	1,600 N-m (1,180 ft.lbs.)
No load speed	Hard / Med. / Soft: 0 - 1,800 / 0 - 1,000 / 0 - 900 min ⁻¹
Impacts per minute	Hard / Med. / Soft: 0 - 2,200 / 0 - 2,000 / 0 - 1,800 min ⁻¹
Dimensions (L x W x H)	229 x 91 x 289 mm (9 x 3-5/8 x 11-3/8")
Net weight	3.3 - 3.6 kg (7.3 - 8 lbs.)

LXI BL MOTOR XPT



Cordless Impact Wrench DTW1004

18V



DTW1004:
Pin-detent
Square drive

Square drive	12.7 mm (1/2")
Max fastening torque	1,050 N-m (780 ft.lbs.)
Fastening capacities	Standard bolt: M12 - M30 (1/2 - 1-1/4") High strength bolt (Grade 10.9): M10 - M20 (3/8 - 3/4")
Nut-busting torque	1,300 N-m (960 ft.lbs.)
No load speed	Hard / Med. / Soft: 0 - 2,000 / 0 - 1,000 / 0 - 900 min ⁻¹
Impacts per minute	Hard / Med. / Soft: 0 - 2,400 / 0 - 2,000 / 0 - 1,800 min ⁻¹
Dimensions (L x W x H)	w/ BL1830B / BL1840B / BL1850B / BL1860B: 223 x 91 x 289 mm (8-3/4 x 3-5/8 x 11-3/8")
Net weight	3.1 - 3.4 kg (6.8 - 7.5 lbs.)

LXI BL MOTOR XPT



Cordless Impact Wrench DTW800

18V



Max fastening torque	800 N-m (590 ft.lbs.)
Fastening capacities	Standard bolt: M12 - M24 (1/2 - 1") High strength bolt: M10 - M22 (3/8 - 7/8")
Hex shank	11.1 mm (7/16")
No load speed	Hard / Med. / Soft: 0 - 1,800 / 0 - 1,000 / 0 - 900 min ⁻¹
Impacts per minute	Hard / Med. / Soft: 0 - 2,200 / 0 - 2,000 / 0 - 1,800 min ⁻¹
Dimensions (L x W x H)	229 x 91 x 303 mm (9 x 3-5/8 x 11-7/8")
Net weight	3.4 - 3.7 kg (8.2 - 7.5 lbs.)

LXI BL MOTOR XPT



Screwing/Drilling

Cordless Impact Wrench
DTW700 / DTW701

18V

DTW700:
C ringDTW701:
Pin detent

Square drive	12.7 mm (1/2")
Max fastening torque	700 N-m (520 ft.lbs.)
Fastening capacities	Standard bolt: M10 - M24 (3/8 - 1") High strength bolt (Grade 10.9): M10 - M16 (3/8 - 5/8")
Nut-busting torque	1,000 N-m (740 ft.lbs.)
No load speed	Max / Hard / Med. / Soft: 0 - 2,200 / 0 - 1,900 / 0 - 1,200 / 0 - 500 min ⁻¹
Impacts per minute	Max / Hard / Med. / Soft: 0 - 2,700 / 0 - 2,400 / 0 - 1,700 / 0 - 1,000 min ⁻¹
Dimensions (L x W x H)	w/ BL1830B / BL1840B / BL1850B / BL1860B: 170 x 81 x 276 mm (6-11/16 x 3-1/8 x 10-7/8")
Net weight	2.3 - 2.7 kg (5.1 - 6.0 lbs.)

LXI BL MOTOR XPT

Cordless Impact Wrench
DTW450

18V



Square drive	12.7 mm (1/2")
Max fastening torque	440 N-m (325 ft.lbs.)
Fastening capacities	Standard bolt: M12 - M22 (1/2 - 7/8") High strength bolt: M12 - M16 (1/2 - 5/8")
No load speed	1,600 min ⁻¹
Impacts per minute	2,200 min ⁻¹
Dimensions (L x W x H)	266 x 82 x 290 mm (10-1/2 x 3-1/4 x 11-3/8")
Net weight	3.1 - 3.4 kg (7.6 - 6.9 lbs.)

LXI

Cordless Impact Wrench
DTW300 / DTW301

18V

DTW300:
C ringDTW301:
Pin detent

Square drive	12.7 mm (1/2")
Max fastening torque	330 N-m (240 ft.lbs.)
Fastening capacities	Standard bolt: M10 - M20 (3/8 - 3/4") High strength bolt: M10 - M16 (3/8 - 5/8")
Nut-busting torque	580 N-m (430 ft.lbs.)
No load speed	Max / Hard / Med. / Soft: 0 - 3,200 / 0 - 2,600 / 0 - 1,800 / 0 - 1,000 min ⁻¹
Impacts per minute	Max / Hard / Med. / Soft: 0 - 4,000 / 0 - 3,400 / 0 - 2,600 / 0 - 1,800 min ⁻¹
Dimensions (L x W x H)	w/ BL1830B / BL1840B / BL1850B / BL1860B: 144 x 81 x 246 mm (5-5/8 x 3-1/8 x 9-11/16")
Net weight	1.5 - 1.8 kg (3.4 - 4.1 lbs.)

LXI BL MOTOR XPT

Cordless Impact Wrench
DTW302

18V



Square drive	9.5 mm (3/8")
Max fastening torque	300 N-m (220 ft.lbs.)
Fastening capacities	Standard bolt: M10 - M20 (3/8 - 3/4") High strength bolt: M10 - M16 (3/8 - 5/8")
Nut-busting torque	500 N-m (370 ft.lbs.)
No load speed	Max / Hard / Med. / Soft: 0 - 3,200 / 0 - 2,600 / 0 - 1,800 / 0 - 1,000 min ⁻¹
Impacts per minute	Max / Hard / Med. / Soft: 0 - 4,000 / 0 - 3,400 / 0 - 2,600 / 0 - 1,800 min ⁻¹
Dimensions (L x W x H)	w/ BL1830B / BL1840B / BL1850B / BL1860B: 138 x 81 x 246 mm (5-7/16 x 3-3/16 x 9-11/16")
Net weight	1.4 - 1.8 kg (3.1 - 4.0 lbs.)

LXI BL MOTOR XPT

Cordless Impact Wrench
DTW251

18V



Square drive	12.7 mm (1/2")
Max fastening torque	230 N-m (170 ft.lbs.)
Fastening capacities	Standard bolt: M10 - M16 (3/8 - 5/8") High strength bolt: M10 - M14 (3/8 - 9/16")
No load speed	0 - 2,100 min ⁻¹
Impacts per minute	0 - 3,200 min ⁻¹
Dimensions (L x W x H)	165 x 79 x 234 mm (6-1/2 x 3-1/8 x 9-1/4")
Net weight	1.5 - 1.8 kg (3.2 - 3.9 lbs.)

Tool does not come with socket.

LXI

Cordless Impact Wrench
DTW253

18V



Square drive	9.5 mm (3/8")
Max fastening torque	210 N-m (155 ft.lbs.)
Fastening capacities	Standard bolt: M8 - M16 (5/16 - 5/8") High strength bolt: M6 - M12 (1/4 - 1/2")
No load speed	0 - 2,100 min ⁻¹
Impacts per minute	0 - 3,200 min ⁻¹
Dimensions (L x W x H)	155 x 79 x 234 mm (6-1/8 x 3-1/8 x 9-1/4")
Net weight	1.3 - 1.6 kg (2.8 - 3.6 lbs.)

Tool does not come with socket.

LXI

Cordless Impact Wrench
DTW181

18V



Square drive	12.7 mm (1/2")
Max fastening torque	210 N-m (155 ft.lbs.)
Fastening capacities	Standard bolt: M8 - M16 (5/16 - 5/8") High strength bolt: M6 - M12 (1/4 - 1/2")
Nut-busting torque	330 N-m (245 ft.lbs.)
No load speed	Hard / Soft: 0 - 2,400 / 0 - 1,300 min ⁻¹
Impacts per minute	Hard / Soft: 0 - 3,600 / 0 - 2,000 min ⁻¹
Dimensions (L x W x H)	w/ BL1830B / BL1840B / BL1850B / BL1860B: 151 x 79 x 235 mm (5-15/16 x 3-1/8 x 9-1/4")
Net weight	1.2 - 1.5 kg (2.7 - 3.4 lbs.)

LXI BL MOTOR XPT

Cordless Impact Wrench
DTW190

18V



Square drive	12.7 mm (1/2")
Max fastening torque	190 N-m (140 ft.lbs.)
Fastening capacities	Standard bolt: M8 - M16 (5/16 - 5/8") High strength bolt: M8 - M12 (1/4 - 1/2")
No load speed	0 - 2,300 min ⁻¹
Impacts per minute	0 - 3,000 min ⁻¹
Overall length	176 mm (6-15/16")
Net weight	1.4 - 1.8 kg (3.2 - 3.9 lbs.)

Tool does not come with socket.

LXI

Cordless Impact Wrench
DTW180

18V



Square drive	9.5 mm (3/8")
Max fastening torque	180 N-m (130 ft.lbs.)
Fastening capacities	Standard bolt: M8 - M16 (5/16 - 5/8") High strength bolt: M6 - M12 (1/4 - 1/2")
Nut-busting torque	310 N-m (230 ft.lbs.)
No load speed	Hard / Soft: 0 - 2,400 / 0 - 1,300 min ⁻¹
Impacts per minute	Hard / Soft: 0 - 3,600 / 0 - 2,000 min ⁻¹
Dimensions (L x W x H)	w/ BL1830B / BL1840B / BL1850B / BL1860B: 144 x 79 x 235 mm (5-5/8 x 3-1/8 x 9-1/4")
Net weight	1.2 - 1.5 kg (2.7 - 3.4 lbs.)

LXI BL MOTOR XPT

Cordless Impact Wrench
TW161D

12V max



Square drive	12.7 mm (1/2")
Max fastening torque	165 N-m (122 ft.lbs.)
Fastening capacities	Standard bolt: M8 - M16 (5/16 - 5/8") High strength bolt: M6 - M12 (1/4 - 1/2")
No load speed	Hard / Soft: 0 - 2,400 / 0 - 1,300 min ⁻¹
Impacts per minute	Hard / Soft: 0 - 3,600 / 0 - 2,000 min ⁻¹
Dimensions (L x W x H)	w/ BL1041B: 150 x 66 x 232 mm (5-7/8 x 2-5/8 x 9-1/8")
Net weight	1.1 - 1.2 kg (2.4 - 2.7 lbs.)

CXI BL MOTOR



Cordless Impact Wrench TW160D

12V max



Square drive	9.5 mm (3/8")
Max fastening torque	160 N-m (120 ft.lbs.)
Fastening capacities	Standard bolt: M8 - M16 (5/16 - 5/8") High strength bolt: M6 - M12 (1/4 - 1/2")
Nut-busting torque	290 N-m (210 ft.lbs.)
No load speed	Hard / Soft: 0 - 2,400 / 0 - 1,300 min ⁻¹
Impacts per minute	Hard / Soft: 0 - 3,600 / 0 - 2,000 min ⁻¹
Dimensions (L x W x H)	w/ BL1041B: 144 x 66 x 232 mm (5-5/8 x 2-5/8 x 9-1/8")
Net weight	1.0 - 1.2 kg (2.2 - 2.6 lbs.)



Cordless Impact Wrench TW141D

12V max



Square drive	12.7 mm (1/2")
Max fastening torque	145 N-m (107 ft.lbs.)
Fastening capacities	Standard bolt: M8 - M16 (5/16 - 5/8") High strength bolt: M6 - M12 (1/4 - 1/2")
Nut-busting torque	270 N-m (200 ft.lbs.)
No load speed	0 - 2,600 min ⁻¹
Impacts per minute	0 - 3,200 min ⁻¹
Dimensions (L x W x H)	w/ BL1041B: 168 x 66 x 224 mm (6-5/8 x 2-5/8 x 8-7/8")
Net weight	1.1 - 1.2 kg (2.4 - 2.7 lbs.)



Cordless Impact Wrench TW140D

12V max



Square drive	9.5 mm (3/8")
Max fastening torque	140 N-m (100 ft.lbs.)
Fastening capacities	Standard bolt: M8 - M16 (5/16 - 5/8") High strength bolt: M6 - M12 (1/4 - 1/2")
Nut-busting torque	270 N-m (200 ft.lbs.)
No load speed	0 - 2,600 min ⁻¹
Impacts per minute	0 - 3,200 min ⁻¹
Dimensions (L x W x H)	w/ BL1041B: 161 x 66 x 224 mm (6-3/8 x 2-5/8 x 8-7/8")
Net weight	1 - 1.2 kg (2.3 - 2.7 lbs.)



Cordless Impact Wrench TW060D

12V max



Square drive	6.35 mm (1/4")
Max fastening torque	60 N-m (44 ft.lbs.)
Fastening capacities	Standard bolt: M8 - M12 (5/16 - 15/32") High strength bolt: M6 - M10 (1/4 - 3/8")
Nut-busting torque	120 N-m (90 ft.lbs.)
No load speed	0 - 2,600 min ⁻¹
Impacts per minute	0 - 3,200 min ⁻¹
Dimensions (L x W x H)	w/ BL1041B: 161 x 66 x 224 mm (6-3/8 x 2-5/8 x 8-7/8")
Net weight	1.0 - 1.2 kg (2.2 - 2.6 lbs.)



Cordless Impact Wrench TW100D

10.8V



Square drive	9.5 mm (3/8")
Max fastening torque	110 N-m (1,000 in.lbs.)
Fastening capacities	Standard bolt: M8 - M12 (5/16 - 1/2") High strength bolt: M6 - M10 (1/4 - 3/8")
No load speed	0 - 2,300 min ⁻¹
Impacts per minute	0 - 3,000 min ⁻¹
Dimensions (L x W x H)	163 x 54 x 178 mm (6-3/8 x 2-1/8 x 7")
Net weight	0.95 kg (2.1 lbs.)



Cordless Impact Wrench TW202D

18V



Square drive	12.7 mm (1/2")
Max fastening torque	200 N-m (148 ft.lbs.)
Fastening capacities	Standard bolt: M8 - M16 (5/16 - 5/8") High strength bolt: M8 - M12 (5/16 - 1/2")
Nut-busting torque	320 N-m (236 ft.lbs.)
No load speed	0 - 2,300 min ⁻¹
Impacts per minute	0 - 3,000 min ⁻¹
Dimensions (L x W x H)	w/ BL1811G / BL1813G / BL1815G / BL1820G: 176 x 79 x 223 mm (6-15/16 x 3-1/8 x 8-3/4")
Net weight	1.5 kg (3.3 lbs.)



Impact Wrench TW1000



Continuous rating	1,200W
Input	
Fastening capacities	Standard bolt: M24 - M30 (15/16 - 1-3/16") High strength bolt: M22 - M24 (7/8 - 15/16")
Square drive	25.4 mm (1")
No load speed	1,400 min ⁻¹
Impacts per minute	1,500 min ⁻¹
Max fastening torque	1,000 N-m (738 ft.lbs.)
Dimensions (L x W x H)	382 x 110 x 290 mm (15 x 4-5/16 x 11-3/8")
Net weight	8.8 kg (19.4 lbs.)



Impact Wrench 6906



Continuous rating	850W
Input	
Capacity	Standard bolt: M16 - M22 (5/8 - 7/8") High strength bolt: M16 - M20 (5/8 - 3/4")
Square drive	19 mm (3/4")
No load speed	1,700 min ⁻¹
Impacts per minute	1,600 min ⁻¹
Max fastening torque	588 N-m (441 ft.lbs.)
Overall length	327 mm (12-7/8")
Net weight	5.6 kg (12.2 lbs.)



Impact Wrench 6905H



Continuous rating	470W
Input	
Fastening capacities	Standard bolt: M12 - M20 (1/2 - 3/4") High strength bolt: M12 - M16 (1/2 - 5/8")
Square drive	12.7 mm (1/2")
No load speed	2,200 min ⁻¹
Impacts per minute	2,600 min ⁻¹
Max fastening torque	294 N-m (217 ft.lbs.)
Dimensions (L x W x H)	275 x 86 x 197 mm (10-7/8 x 3-3/8 x 7-3/4")
Net weight	2.4 kg (5.2 lbs.)



Impact Wrench TW0350



Continuous rating	400W
Input	
Fastening capacities	Standard bolt: M12 - M22 (1/2 - 7/8") High strength bolt: M12 - M16 (1/2 - 5/8")
Square drive	12.7 mm (1/2")
No load speed	2,000 min ⁻¹
Impacts per minute	2,000 min ⁻¹
Max fastening torque	350 N-m (260 ft.lbs.)
Dimensions (L x W x H)	283 x 87 x 233 mm (11-1/8 x 3-7/16 x 9-1/8")
Net weight	3 kg (6.6 lbs.)



Screwing/Drilling

Impact Wrench
TW0200

Continuous rating Input	380W
Fastening capacities	Standard bolt: M10 - M16 (3/8 - 5/8") High strength bolt: M10 - M12 (3/8 - 1/2")
Square drive	12.7 mm (1/2")
No load speed	0 - 2,200 min ⁻¹
Impacts per minute	0 - 2,200 min ⁻¹
Max fastening torque	200 N-m (150 ft.lbs.)
Dimensions (L x W x H)	251 x 72 x 220 mm (9-7/8 x 2-13/16 x 8-5/8")
Net weight	2.1 kg (4.7 lbs.)

Impact Wrench
6953

Continuous rating Input	280W
Fastening capacities	Standard bolt: M10 - M16 (3/8 - 5/8") High strength bolt: M8 - M12 (5/16 - 1/2")
Square drive	12.7 mm (1/2")
No load speed	0 - 3,000 min ⁻¹
Impacts per minute	0 - 3,000 min ⁻¹
Max fastening torque	150 N-m (111 ft.lbs.)
Overall length	233 mm (9-1/8")
Net weight	1.5 kg (3.2 lbs.)

Cordless Ratchet Wrench
DWR180

18V



Capacity	Standard bolt: M5 - M12 (3/16 - 1/2") High strength bolt: M5 - M10 (3/16 - 3/8")
Square drive	9.5 / 6.35 mm (3/8 / 1/4")
Max fastening torque	47.5 N-m (420 in.lbs.)
No load speed	0 - 800 min ⁻¹
Flats width	13 mm (1/2")
Angle head size	Diameter: 31 mm (1-7/32") Height: 25.5 mm (1")
Dimensions (L x W x H)	w/ BL1830B / BL1840B / BL1850B / BL1860B: 369 x 79 x 87 mm (14-1/2 x 3-1/8 x 3-7/16")
Net weight	1.2 - 1.6 kg (2.6 - 3.5 lbs.)

LXI XPT

Cordless Ratchet Wrench
WR100D

12V max



Capacity	Standard bolt: M5 - M12 (3/16 - 1/2") High strength bolt: M5 - M10 (3/16 - 3/8")
Square drive	9.5 / 6.35 mm (3/8 / 1/4")
Max fastening torque	47.5 N-m (420 in.lbs.)
No load speed	0 - 800 min ⁻¹
Flats width	13 mm (1/2")
Angle head size	Diameter: 31 mm (1-7/32") Height: 25.5 mm (1")
Dimensions (L x W x H)	w/ BL1041B: 341 x 67 x 84 mm (13-7/16 x 2-5/8 x 3-5/16")
Net weight	1.0 - 1.2 kg (2.3 - 2.7 lbs.)

CXT XPT

Cordless Angle Impact Wrench
DTL063

18V



Fastening capacities	Standard bolt: M4 - M12 (5/32 - 1/2") High strength bolt: M4 - M8 (5/32 - 5/16")
Square drive	9.5 mm (3/8")
No load speed	0 - 2,000 min ⁻¹
Impacts per minute	0 - 3,000 min ⁻¹
Max fastening torque	60 N-m
Dimensions (L x W x H)	387 x 78 x 116 mm (15-1/4 x 3-1/16 x 4-9/16")
Net weight	1.4 - 2 kg (3.1 - 4.3 lbs.)

LXI

Cordless Angle Impact Wrench
TL065D

12V max



Capacity	Standard bolt: M4 - M12 (5/32 - 1/2") High strength bolt: M4 - M8 (5/32 - 5/16")
Square drive	9.5 mm (3/8")
No load speed	0 - 2,000 min ⁻¹
Impacts per minute	0 - 3,000 min ⁻¹
Max fastening torque	60 N-m (530 in.lbs.)
Dimensions (L x W x H)	361 x 66 x 86 mm (14-1/4 x 2-5/8 x 3-3/8")
Net weight	1.2 - 1.6 kg (2.7 - 3.6 lbs.)

CXT

Cordless Shear Wrench
WT001G

40V max



Capacity	High strength torque shear bolt (HTB): M16, M20, M22 (5/8, 3/4, 7/8) Super (high) strength torque shear bolt (SHTB): M16, M20 (5/8, 3/4")
No load speed	17 min ⁻¹
Max fastening torque	804 N-m (593 ft.lbs.)
Dimensions (L x W x H)	w/ M22 Sleeve, w/ BL4040: 270 x 95 x 340 mm (10-5/8 x 3-3/4 x 13-3/8")
Net weight	5.2 - 5.9 kg (11.5 - 13 lbs.)

XGT BL MOTOR XPT

Cordless Shear Wrench
DWT310

18V x2



Capacity	High strength torque shear bolt (HTB): M16, M20, M22 (5/8, 3/4, 7/8) Super (high) strength torque shear bolt (SHTB): M16, M20 (5/8, 3/4")
No load speed	14 min ⁻¹
Max fastening torque	804 N-m (593 ft.lbs.)
Dimensions (L x W x H)	296 x 130 x 377 mm (11-5/8 x 5-1/8 x 14-7/8")
Net weight	6.5 - 7.1 kg (14.3 - 15.7 lbs.)

LXI BL MOTOR XPT

Shear Wrench
6924N

Continuous rating Input	1,050W
Capacity	Bolt: M22, M24 (7/8, 1") Super high tensile bolt: M22
No load speed	19 min ⁻¹
Max fastening torque	1,100 N-m (810 ft.lbs.)
Dimensions (L x W x H)	330 x 104 x 257 mm (13 x 4-1/8 x 10-1/8")
Net weight	7.5 kg (16.6 lbs.)

Shear Wrench
6922NB

Continuous rating Input	1,330W
Capacity	Bolt: M16, M20, M22 (5/8, 3/4, 7/8")
No load speed	18 min ⁻¹
Max fastening torque	804 N-m (593 ft.lbs.)
Dimensions (L x W x H)	249 x 84 x 252 mm (9-13/16 x 3-5/16 x 9-15/16")
Net weight	4.9 kg (10.8 lbs.)



Diamond Core Drill DBM080

Continuous rating Input	1,300W
Capacity	Concrete (w/ Diamond core bit): 82 mm (3-1/4")
Tool holder	(Spindle): M18
No load speed	0 - 3,400 min ⁻¹
Net weight	3.4 kg (7.5 lbs.)



Diamond Core Drill DBM130

Continuous rating Input	1,700W
Capacity	Concrete (w/ Diamond core bit) Hi: 70 mm (2-3/4") Concrete (w/ Diamond core bit) Lo: 132 mm (5-3/16")
Tool holder	(Spindle): M18
No load speed	High: 0 - 3,000 min ⁻¹ Low: 0 - 1,500 min ⁻¹
Net weight	5.5 kg (12.1 lbs.)



Diamond Core Drill DBM230

Continuous rating Input	2,500W
Capacity	Concrete (w/ Diamond core bit): 230 mm (9")
No load speed	3rd: 1,700 min ⁻¹ 2nd: 1,040 min ⁻¹ 1st: 390 min ⁻¹
Net weight	37.5 kg (82.7 lbs.)



Diamond Core Drill DBM131

Continuous rating Input	1,700W
Capacity	Concrete (w/ Diamond core bit) Hi: 70 mm (2-3/4") Concrete (w/ Diamond core bit) Lo: 132 mm (5-3/16")
Tool holder	(Spindle): M18
No load speed	High: 0 - 2,300 min ⁻¹ Low: 0 - 1,100 min ⁻¹
Net weight	6.3 kg (13.9 lbs.)



Cordless Earth Auger DG002G

40V max

Max drilling capacity	200 mm
Capacity	Clay soil, High: 60 mm Clay soil, Low: 150 mm Sandy soil, High: 60 mm Sandy soil, Low: 200 mm
No load speed	High: 0 - 1,500 min ⁻¹ Low: 0 - 400 min ⁻¹
Max torque	High: 55 N-m (487 in.lbs) Low: 136 N-m (1,210 in.lbs)
Dimensions (L x W x H)	w/ BL4040: 842 x 605 x 194 mm (33-1/4 x 23-3/4 x 7-5/8")
Net weight	6.8 - 8.0 kg (15.0 - 17.6 lbs.)



Cordless Earth Auger DG001G

40V max

Max drilling capacity	200 mm
Capacity	Clay soil: 150 mm Sandy soil: 200 mm
Chuck capacity	2 - 13 mm (1/16 - 1/2")
No load speed	High: 0 - 1,500 min ⁻¹ Low: 0 - 400 min ⁻¹
Max torque	High: 55 N-m (487 in.lbs) Low: 136 N-m (1,210 in.lbs)
Dimensions (L x W x H)	w/ BL4050F: 863 x 605 x 199 mm (34 x 23-3/4 x 7-7/8")
Net weight	7.2 - 8.1 kg (15.9 - 17.9 lbs.)



Cordless Earth Auger DDG461

18V x2

Max drilling capacity	200 mm
Capacity	Clay soil, High: 60 mm Clay soil, Low: 150 mm Sandy soil, High: 60 mm Sandy soil, Low: 200 mm
No load speed	High: 0 - 1,400 min ⁻¹ Low: 0 - 350 min ⁻¹
Max torque	High: 48 N-m (430 in.lbs) Low: 136 N-m (1,210 in.lbs)
Dimensions (L x W x H)	w/ BL1830B / BL1840B / BL1850B / BL1860B: 840 x 607 x 223 mm (33 x 23-7/8 x 8-3/4")
Net weight	7.0 - 7.6 kg (15.4 - 16.8 lbs.)



Cordless Earth Auger DDG460

18V x2

Capacity	Clay soil: 150 mm Sandy soil: 200 mm
Chuck capacity	2 - 13 mm (5/64 - 1/2")
No load speed	High: 0 - 1,400 min ⁻¹ Low: 0 - 350 min ⁻¹
Dimensions (L x W x H)	w/ BL1830B / BL1840B / BL1850B / BL1860B: 840 x 607 x 223 mm (33 x 23-7/8 x 8-3/4")
Net weight	7.3 - 8.2 kg (16.1 - 18.1 lbs.)



Cordless Screwdriver DFS452

18V

Capacity	Self-drilling screw: 6 mm (1/4") Drywall screw: 5 mm (3/16")
Driving shank (Hex)	6.35 mm (1/4")
No load speed	0 - 4,000 min ⁻¹
Dimensions (L x W x H)	251 x 79 x 259 mm (10 x 3-1/8 x 11-1/4")
Net weight	1.5 - 1.8 kg (3.2 - 3.9 lbs.)



Cordless Screwdriver DFS451

18V

Capacity	Drywall screw: 4 mm (5/32")
Driving shank (Hex)	6.35 mm (1/4")
No load speed	0 - 4,000 min ⁻¹
Dimensions (L x W x H)	281 x 80 x 241 mm (11-1/8 x 3-1/8 x 9-1/2")
Net weight	1.5 - 1.8 kg (3.2 - 4 lbs.)



Screwing/Drilling

Cordless Screwdriver DFS250

18V



Capacity	Coarse thread: 4.5 x 90 mm (3/16 x 3-1/2") Self-drilling screw: 6 mm (1/4") Drywall screw: 5 mm (3/16")
Driving shank (Hex)	6.35 mm (1/4")
No load speed	0 - 2,500 min ⁻¹
Dimensions (L x W x H)	259 x 79 x 259 mm (10-1/4 x 3-1/8 x 10-1/4")
Net weight	1.5 - 1.9 kg (3.4 - 4.1 lbs.)



Cordless Screwdriver DFS251

18V



Capacity	Self-drilling screw: 6 mm (1/4") Drywall screw: 5 mm (3/16") Hex socket screw: 6 mm (1/4")
Driving shank (Hex)	6.35 mm (1/4")
No load speed	0 - 2,500 min ⁻¹
Dimensions (L x W x H)	237 x 79 x 259 mm (9-3/8 x 3-1/8 x 11-1/4")
Net weight	1.5 - 1.8 kg (3.2 - 3.9 lbs.)



Screwdriver FS2700



Continuous rating	570W
Input	
Capacity	Self-drilling screw: 6 mm (1/4") Machine screw: 8 mm (5/16") Wood screw: 6.2 mm (1/4")
Driving shank (Hex)	6.35 mm (1/4")
No load speed	0 - 2,500 min ⁻¹
Dimensions (L x W x H)	301 x 70 x 207 mm (11-7/8 x 2-3/4 x 8-1/8")
Net weight	1.8 kg (4 lbs.)



Screwdriver FS2701



Continuous rating	570W
Input	
Capacity	Self-drilling screw: 6 mm (1/4") Machine screw: 8 mm (5/16") Wood screw: 6.2 mm (1/4")
Driving shank (Hex)	6.35 mm (1/4")
No load speed	0 - 2,500 min ⁻¹
Dimensions (L x W x H)	283 x 70 x 207 mm (11-1/8 x 2-3/4 x 8-1/8")
Net weight	1.7 kg (3.8 lbs.)



Screwdriver FS2500



Continuous rating	570W
Input	
Capacity	Drywall screw: 5 mm (3/16") Self-drilling screw: 6 mm (1/4")
Driving shank (Hex)	6.35 mm (1/4")
No load speed	0 - 2,500 min ⁻¹
Dimensions (L x W x H)	280 x 70 x 207 mm (11 x 2-3/4 x 8-1/8")
Net weight	1.5 kg (3.4 lbs.)



Cordless Auto Feed Screwdriver DFR452

18V



Screw strip	3.5 - 4.2 x 20 - 41 mm (1/8 - 5/32 x 13/16 - 1-5/8")
Driving shank (Hex)	6.35 mm (1/4")
No load speed	0 - 6,000 min ⁻¹
Dimensions (L x W x H)	w/ BL1830B / BL1840B / BL1850B / BL1860B: 360 x 88 x 211 mm (14-1/8 x 3-1/2 x 8-5/16")
Net weight	1.9 - 2.2 kg (4.2 - 4.9 lbs.)



Cordless Auto Feed Screwdriver DFR551

18V



Screw strip	3.5 - 4.2 x 25 - 55 mm (1/8 - 5/32 x 1 - 2-3/16")
Driving shank (Hex)	6.35 mm (1/4")
No load speed	0 - 6,000 min ⁻¹
Dimensions (L x W x H)	w/ BL1830B / BL1840B / BL1850B / BL1860B: 396 x 88 x 211 mm (15-5/8 x 3-1/2 x 8-5/16")
Net weight	1.9 - 2.2 kg (4.2 - 4.9 lbs.)



Cordless Auto Feed Screwdriver DFR453

18V



new

Screw strip	3.5 - 4.2 x 20 - 41 mm (1/8 - 5/32 x 13/16 - 1-5/8")
Driving shank (Hex)	6.35 mm (1/4")
No load speed	0 - 4,500 min ⁻¹
Dimensions (L x W x H)	w/ BL1830B / BL1840B / BL1850B / BL1860B: 360 x 88 x 211 mm (14-1/8 x 3-1/2 x 8-5/16")
Net weight	1.9 - 2.2 kg (4.2 - 4.9 lbs.)



Cordless Auto Feed Screwdriver DFR552

18V



new

Screw strip	3.5 - 4.2 x 25 - 55 mm (1/8 - 5/32 x 1 - 2-3/16")
Driving shank (Hex)	6.35 mm (1/4")
No load speed	0 - 4,500 min ⁻¹
Dimensions (L x W x H)	w/ BL1830B / BL1840B / BL1850B / BL1860B: 396 x 88 x 211 mm (15-5/8 x 3-1/2 x 8-5/16")
Net weight	1.9 - 2.2 kg (4.2 - 4.9 lbs.)



Screwing/Drilling

Cordless Auto Feed Screwdriver DFR550

18V



Screw strip	4 x 25 - 55 mm (5/32 x 1 - 2-3/16")
Driving shank (Hex)	6.35 mm (1/4")
No load speed	4,000 min ⁻¹
Dimensions (L x W x H)	424 x 80 x 238 mm (16-3/4 x 3-1/8 x 9-3/8")
Net weight	2.1 - 3.1 kg (4.6 - 6.9 lbs.)



Cordless Auto Feed Screwdriver DFR750

18V



Screw strip	4 x 45 - 75 mm (5/32 x 1-3/4 - 2-15/16")
Driving shank (Hex)	6.35 mm (1/4")
No load speed	4,000 min ⁻¹
Dimensions (L x W x H)	464 x 80 x 238 mm (18-1/4 x 3-1/8 x 9-3/8")
Net weight	2.1 - 3.2 kg (4.6 - 7 lbs.)



Drywall Screwdriver FS4300



Continuous rating	570W
Input	
Capacity	Drywall screw: 5 mm (3/16") Self-drilling screw: 6 mm (1/4")
Driving shank (Hex)	6.35 mm (1/4")
No load speed	0 - 4,000 min ⁻¹
Dimensions (L x W x H)	279 x 65 x 207 mm (11 x 2-9/16 x 8-1/8")
Net weight	1.4 kg (3.1 lbs.)



Drywall Screwdriver FS4200



Continuous rating	570W
Input	
Capacity	Drywall screw: 5 mm (3/16") Self-drilling screw: 6 mm (1/4")
Driving shank (Hex)	6.35 mm (1/4")
No load speed	0 - 4,000 min ⁻¹
Dimensions (L x W x H)	269 x 65 x 207 mm (10-5/8 x 2-9/16 x 8-1/8")
Net weight	1.4 kg (3 lbs.)



Drywall Screwdriver FS4000



Continuous rating	570W
Input	
Capacity	Drywall screw: 5 mm (3/16") Self-drilling screw: 6 mm (1/4")
Driving shank (Hex)	6.35 mm (1/4")
No load speed	0 - 4,000 min ⁻¹
Dimensions (L x W x H)	269 x 65 x 207 mm (10-5/8 x 2-9/16 x 8-1/8")
Net weight	1.3 kg (2.9 lbs.)



Drywall Screwdriver FS2300



Continuous rating	570W
Input	
Capacity	Drywall screw: 5 mm (3/16") Self-drilling screw: 6 mm (1/4")
Driving shank (Hex)	6.35 mm (1/4")
No load speed	0 - 2,500 min ⁻¹
Dimensions (L x W x H)	290 x 70 x 207 mm (11-3/8 x 2-3/4 x 8-1/8")
Net weight	1.6 kg (3.5 lbs.)



Drywall Screwdriver FS2200



Continuous rating	570W
Input	
Capacity	Drywall screw: 5 mm (3/16") Self-drilling screw: 6 mm (1/4")
Driving shank (Hex)	6.35 mm (1/4")
No load speed	0 - 2,500 min ⁻¹
Dimensions (L x W x H)	287 x 70 x 207 mm (11-1/4 x 2-3/4 x 8-1/8")
Net weight	1.6 kg (3.5 lbs.)



Drywall Screwdriver FS6300R



Continuous rating	570W
Input	
Capacity	Drywall screw: 4 mm (5/32")
Driving shank (Hex)	6.35 mm (1/4")
No load speed	0 - 6,000 min ⁻¹
Dimensions (L x W x H)	279 x 65 x 207 mm (11 x 2-9/16 x 8-1/8")
Net weight	1.4 kg (3.1 lbs.)



Drywall Screwdriver FS6300



Continuous rating	570W
Input	
Capacity	Drywall screw: 4 mm (5/32")
Driving shank (Hex)	6.35 mm (1/4")
No load speed	0 - 6,000 min ⁻¹
Dimensions (L x W x H)	279 x 65 x 207 mm (11 x 2-9/16 x 8-1/8")
Net weight	1.4 kg (3.1 lbs.)



Drywall Screwdriver FS6200



Continuous rating	570W
Input	
Capacity	Drywall screw: 4 mm (5/32")
Driving shank (Hex)	6.35 mm (1/4")
No load speed	0 - 6,000 min ⁻¹
Dimensions (L x W x H)	269 x 65 x 207 mm (10-5/8 x 2-9/16 x 8-1/8")
Net weight	1.4 kg (3 lbs.)



Comparison List

Model No.	No load speed (rpm)	Mechanical 3-Speed / 2-Speed	Torque Setting	Max torque (N-m)	Overall length (mm)	Net weight (kg)	BL motor
Cordless Driver Drill (DF001D: In-Line Cordless Screwdriver)							
DF001G	0 - 2,600 / 650	2-Speed	21 / 41	150	181	2.7 - 3.0 kg (5.9 - 6.6 lbs.)	●
DF002G	0 - 2,200 / 600	2-Speed	21	70	164	1.9 - 2.5 kg (4.2 - 5.5 lbs.)	●
DDF486	0 - 2,100 / 550	2-Speed	21	141	178	2.3 - 2.6 kg (5.1 - 5.7 lbs.)	●
DDF489	0 - 1,800 / 550	2-Speed	21	110	174	1.8 - 2.5 kg (4.0 - 5.5 lbs.)	●
DDF484	0 - 2,000 / 500	2-Speed	21	65	172	1.5 - 1.8 kg (3.3 - 4.0 lbs.)	●
DDF485	0 - 1,900 / 500	2-Speed	21	60	169	1.4 - 1.7 kg (3.1 - 3.8 lbs.)	●
DDF487	0 - 1,700 / 500	2-Speed	20	40	150	1.3 - 1.6 kg (2.9 - 3.5 lbs.)	●
DDF458	0 - 2,000 / 400	2-Speed	21	110	225	2.1 - 2.5 kg (4.7 - 5.4 lbs.)	-
DDF451	0 - 1,700 / 600 / 300	3-Speed	16	63	238	2.3 - 2.6 kg (5.0 - 5.7 lbs.)	-
DDF482	0 - 1,900 / 600	2-Speed	21	64	185	1.5 - 1.8 kg (3.2 - 4.0 lbs.)	-
DDF453	0 - 1,300 / 400	2-Speed	16	48	222	1.7 - 2.0 kg (3.7 - 4.4 lbs.)	-
DDF083	0 - 1,700 / 500	2-Speed	20	40	124	1.1 - 1.4 kg (2.4 - 3.0 lbs.)	●
DF332D	0 - 1,500 / 450	2-Speed	20	38	154	1 - 1.2 kg (2.3 - 2.6 lbs.)	●
DF032D	0 - 1,500 / 450	2-Speed	20	38	124	0.88 - 1 kg (1.9 - 2.3 lbs.)	●
DF333D	0 - 1,700 / 450	2-Speed	20	34	179	1.1 - 1.2 kg (2.4 - 2.7 lbs.)	-
DF033D	0 - 1,700 / 450	2-Speed	20	34	149	0.9 - 1.1 kg (2.1 - 2.4 lbs.)	-
DF030D	0 - 1,300 / 350	2-Speed	18	28	157	0.89 kg (2 lbs.)	-
DF330D	0 - 1,300 / 350	2-Speed	18	28	189	1 kg (2.2 lbs.)	-
DF012D	650 / 200	2-Speed	21	11	218	0.53 kg (1.2 lbs.)	-
DF001D	220	-	-	9	287	0.36 kg (0.79 lbs.)	-
DF488D	0 - 1,400 / 400	2-Speed	16	47	221	1.7 kg (3.7 lbs.)	-
DF347D	0 - 1,400 / 400	2-Speed	16	34	198	1.4 kg (3.2 lbs.)	-
Cordless Hammer Driver Drill							
HP001G	0 - 2,600 / 650	2-Speed	21 / 41	150	182	2.7 - 3.0 kg (6.0 - 6.6 lbs.)	●
HP002G	0 - 2,200 / 600	2-Speed	21	70	174	2.0 - 2.6 kg (4.4 - 5.7 lbs.)	●
DHP486	0 - 2,100 / 550	2-Speed	21	141	178	2.3 - 2.7 kg (5.1 - 6.0 lbs.)	●
DHP489	0 - 1,800 / 550	2-Speed	21	110	175	1.8 - 2.5 kg (4.0 - 5.5 lbs.)	●
DHP484	0 - 2,000 / 500	2-Speed	21	65	182	1.6 - 1.9 kg (3.5 - 4.2 lbs.)	●
DHP485	0 - 1,900 / 500	2-Speed	21	60	182	1.5 - 1.8 kg (3.2 - 3.9 lbs.)	●
DHP487	0 - 1,700 / 500	2-Speed	20	40	164	1.4 - 1.7 kg (3.1 - 3.7 lbs.)	●
DHP458	0 - 2,000 / 400	2-Speed	21	110	225	2.2 - 2.6 kg (4.9 - 5.7 lbs.)	-
DHP451	0 - 1,700 / 600 / 300	3-Speed	16	63	250	2.5 - 2.9 kg (5.6 - 6.3 lbs.)	-
DHP482	0 - 1,900 / 600	2-Speed	21	64	198	1.5 - 1.8 kg (3.4 - 4.1 lbs.)	-
DHP453	0 - 1,300 / 400	2-Speed	16	48	240	1.7 - 2.0 kg (3.6 - 4.4 lbs.)	-
HP333D	0 - 1,700 / 450	2-Speed	20	34	193	1.1 - 1.3 kg (2.4 - 2.9 lbs.)	-
HP332D	0 - 1,500 / 450	2-Speed	20	38	168	1.1 - 1.3 kg (2.4 - 2.8 lbs.)	●
HP330D	0 - 1,500 / 400	2-Speed	18	28	201	1.1 kg (2.3 lbs.)	-
HP488D	0 - 1,400 / 400	2-Speed	16	47	239	1.8 kg (4.0 lbs.)	-
HP347D	0 - 1,400 / 400	2-Speed	16	34	216	1.4 kg (3.1 lbs.)	-

Comparison List

Model No.	No load speed (min ⁻¹)	Electronic Speed	Max. fastening torque (N-m)	Overall length (mm)	Net weight (kg)	BL motor
-----------	------------------------------------	------------------	-----------------------------	---------------------	-----------------	----------

Cordless Impact Driver

TD002G	0 - 3,700 / 3,200 / 2,100 / 1,100	4-Speed	220	119	1.7 - 2.9 kg (3.7 - 6.4 lbs.)	●
TD001G	0 - 3,700 / 3,200 / 2,100 / 1,100	4-Speed	220	120	1.7 - 2.0 kg (3.7 - 4.4 lbs.)	●
TD003G	0 - 3,700 / 3,200 / 2,100 / 1,100	4-Speed	210	121	1.7 - 2.9 kg (3.7 - 6.4 lbs.)	●
DTD173	0 - 3,600 / 3,200 / 2,100 / 1,100	4-Speed	180	111	1.5 kg (3.3 lbs.)	●
DTD154	0 - 3,600 / 2,100 / 1,100	3-Speed	175	117	1.3 - 1.6 kg (2.7 - 3.4 lbs)	●
DTD153	0 - 3,400	-	170	126	1.3 - 1.6 kg (2.8 - 3.5 lbs)	●
DTD152	0 - 2,900	-	165	137	1.3 - 1.6 kg (2.8 - 3.5 lbs)	-
DTD156	0 - 2,500	-	155	143	1.3 - 1.6 kg (2.9 - 3.6 lbs.)	-
DTD157	0 - 3,000 / 1,300	2-Speed	140	133	1.2 - 1.5 kg (2.6 - 3.3 lbs)	●
TD111D	0 - 3,000 / 1,300	2-Speed	135	135	0.97 - 1.1 kg (2.1 - 2.5 lbs.)	●
TD110D	0 - 2,600	-	110	153	1 - 1.2 kg (2.3 - 2.6 lbs.)	-
TD090D	0 - 2,400	-	90	155	0.92 kg (2 lbs.)	-
TD022D	0 - 2,450	-	25	227	0.55 - 0.56 kg (1.2 lbs.)	-
TD127D	0 - 2,300	-	140	173	1.5 kg (3.2 lbs.)	-
TD126D	0 - 2,400	-	135	173	1.4 kg (3.1 lbs.)	-

Cordless 4 Mode Impact Driver (Impact-driver mode)

DTP141	0 - 2,700 / 2,200 / 1,300	3-Speed	150	171	1.5 - 1.9 kg (3.4 - 4.1 lbs)	●
--------	---------------------------	---------	-----	-----	------------------------------	---

Cordless Oil-Pulse Driver

DTS141	0 - 3,200 / 2,000 / 1,200	3-Speed	40	136	1.3 - 1.6 kg (2.8 - 3.5 lbs)	●
--------	---------------------------	---------	----	-----	------------------------------	---

Model No.	Square drive	Max Fastening Torque (N-m)	No load speed (rpm)	Overall length (mm)	Net weight (kg)	BL motor
-----------	--------------	----------------------------	---------------------	---------------------	-----------------	----------

Cordless Impact Wrench

TW010G	1" (25.4 mm)	3,150	0 - 1,200 / 850 / 700 / 600	570	12.0 - 12.9 kg (26.5 - 28.4 lbs.)	●
TW001G	3/4" (19 mm)	1,800	0 - 1,800 / 1,400 / 1,150 / 950	217	3.9 - 4.2 kg (8.6 - 9.3 lbs.)	●
TW002G	1/2" (12.7mm)	1,700	0 - 1,800 / 1,000 / 900 / 850	213	3.9 - 5.1 kg (8.6 - 11.2 lbs.)	●
TW003G	1/2" (12.7mm)	1,360	0 - 1,800 / 1,200 / 1,000 / 800	213	3.8 - 5.0 kg (8.4 - 11.0 lbs.)	●
TW007G	1/2" (12.7mm)	760	0 - 2,300 / 1,900 / 1,200 / 600	170	2.7 - 3.3 kg (6.0 - 7.3 lbs.)	●
TW008G	1/2" (12.7mm)	760	0 - 2,300 / 1,900 / 1,200 / 600	170	2.7 - 3.3 kg (6.0 - 7.3 lbs.)	●
TW004G	1/2" (12.7mm)	350	0 - 3,200 / 2,600 / 1,800 / 1,000	144	1.9 - 2.2 kg (4.2 - 4.9 lbs.)	●
TW005G	1/2" (12.7mm)	350	0 - 3,200 / 2,600 / 1,800 / 1,000	144	1.9 - 2.2 kg (4.2 - 4.9 lbs.)	●
DTW1001	3/4" (19mm)	1,250	0-1,800 / 1,000 / 900	229	3.4 - 3.7 kg (7.5 - 8.2 lbs)	●
DTW1002	1/2" (12.7mm)	1,200	0-1,800 / 1,000 / 900	229	3.3 - 3.6 kg (7.3 - 8.0 lbs)	●
DTW1004	1/2" (12.7mm)	1,050	0-2,000 / 1,000 / 900	223	3.1 - 3.4 kg (6.8 - 7.5 lbs.)	●
DTW800	7/16" (11.2mm) Hex.	800	0-1,800 / 1,000 / 900	229	3.4 - 3.7 kg (8.2 - 7.5 lbs)	●
DTW700	1/2" (12.7mm)	700	0 - 2,200 / 1,900 / 1,200 / 500	170	2.3 - 2.7 kg (5.1 - 6.0 lbs)	●
DTW701	1/2" (12.7mm)	700	0 - 2,200 / 1,900 / 1,200 / 500	170	2.3 - 2.7 kg (5.1 - 6.0 lbs)	●
DTW450	1/2" (12.7mm)	440	1,600	266	3.1 - 3.4 kg (7.6 - 6.9 lbs)	-
DTW300	1/2" (12.7mm)	330	0 - 3,200 / 2,600 / 1,800 / 1,000	144	1.5 - 1.8 kg (3.4 - 4.1 lbs.)	●
DTW301	1/2" (12.7mm)	330	0 - 3,200 / 2,600 / 1,800 / 1,000	144	1.5 - 1.8 kg (3.4 - 4.1 lbs.)	●
DTW302	3/8" (9.5 mm)	300	0 - 3,200 / 2,600 / 1,800 / 1,000	138	1.4 - 1.8 kg (3.1 - 4.0 lbs.)	●
DTW251	1/2" (12.7mm)	230	0-2,100	165	1.5 - 1.8 kg (3.2 - 3.9 lbs)	-
DTW253	3/8" (9.5mm)	210	0-2,100	155	1.3 - 1.6 kg (2.8 - 3.6 lbs)	-
DTW181	1/2" (12.7mm)	210	0-2,400 / 1,300	151	1.2 - 1.5 kg (2.7 - 3.4 lbs.)	●
DTW190	1/2" (12.7mm)	190	0-2,300	176	1.4 - 1.8 kg (3.2 - 3.9 lbs)	-
DTW180	3/8" (9.5mm)	180	0-2,400 / 1,300	144	1.2 - 1.5 kg (2.7 - 3.4 lbs.)	●
TW161D	1/2" (12.7 mm)	165	0-2,400 / 1,300	150	1.1 - 1.2 kg (2.4 - 2.7 lbs.)	●
TW160D	3/8" (9.5 mm)	160	0-2,400 / 1,300	144	1.0 - 1.2 kg (2.2 - 2.6 lbs.)	●
TW141D	1/2" (12.7 mm)	145	0-2,600	168	1.1 - 1.2 kg (2.4 - 2.7 lbs.)	-
TW140D	3/8" (9.5 mm)	140	0-2,600	161	1.0 - 1.2 kg (2.3 - 2.7 lbs.)	-
TW060D	1/4" (6.35 mm)	60	0-2,600	161	1.0 - 1.2 kg (2.2 - 2.6 lbs.)	-
TW100D	3/8" (9.5 mm)	110	0-2,300	163	0.95 kg (2.1 lbs.)	-
TW202D	1/2" (12.7 mm)	200	0 - 2,300	176	1.5 kg (3.3 lbs.)	-

Cordless Tools for Industry



Screwdriver, Angle Screwdriver

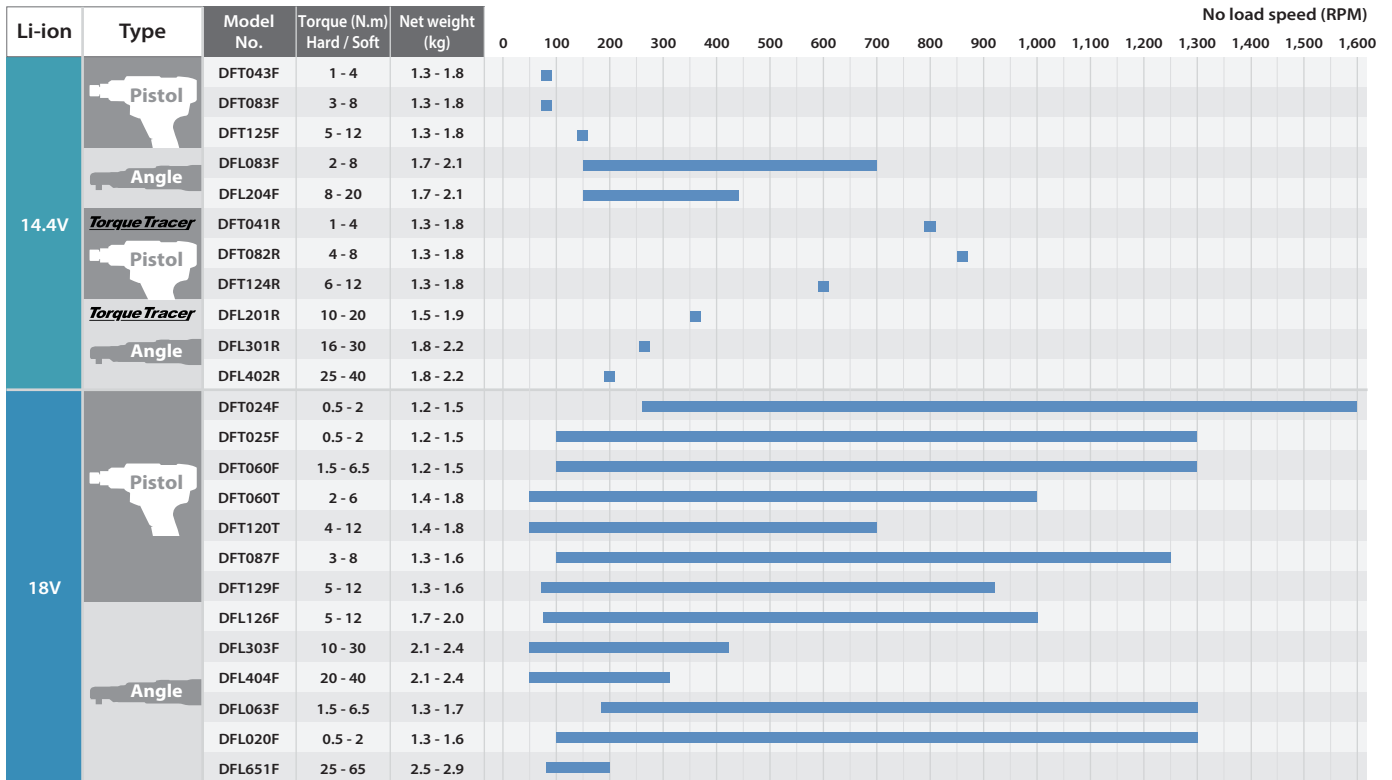

Impact Driver, Impact Wrench

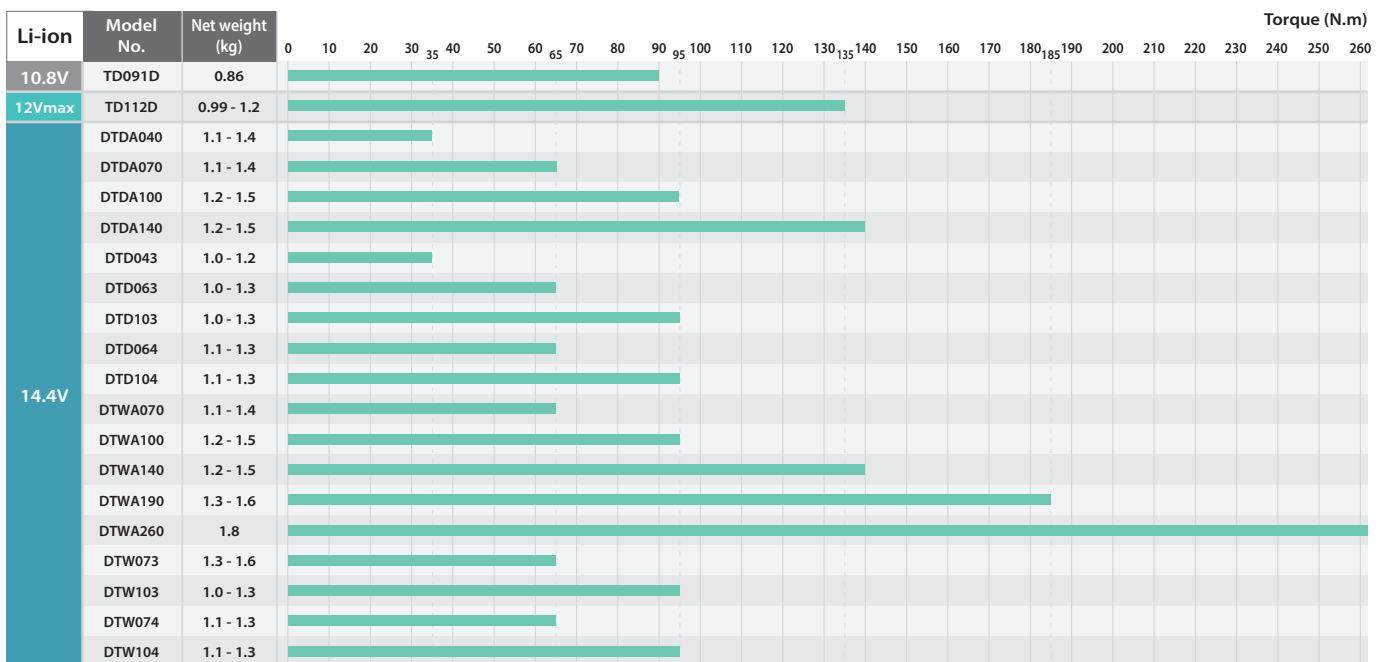

Cordless Screwdriver

18V



LXT BL MOTOR



	DFT060T	DFT120T
Driving shank (Hex)	6.35 mm (1/4")	6.35 mm (1/4")
No load speed	50 - 1,000 min ⁻¹	50 - 700 min ⁻¹
Fastening torque	Hard / Soft: 2 - 6 / 2 - 6 N-m (18 - 53 / 18 - 53 in.lbs.)	Hard / Soft: 4 - 12 / 4 - 12 N-m (35 - 106 / 35 - 106 in.lbs.)
Dimensions (L x W x H)	w/ BL1830B / BL1840B / BL1850B / BL1860B: 206 x 75 x 263 mm (8-1/8 x 2-15/16 x 10-3/8")	w/ BL1830B / BL1840B / BL1850B / BL1860B: 206 x 75 x 263 mm (8-1/8 x 2-15/16 x 10-3/8")
Net weight	1.4 - 1.8 kg (3.1 - 4.0 lbs.)	1.4 - 1.8 kg (3.1 - 4.0 lbs.)

Cordless Screwdriver

18V



LXT BL MOTOR



	DFT024F	DFT025F	DFT060F
Driving shank (Hex)	6.35 mm (1/4")	6.35 mm (1/4")	6.35 mm (1/4")
No load speed	260 - 1,600 min ⁻¹	100 - 1,300 min ⁻¹	100 - 1,300 min ⁻¹
Fastening torque	Hard / Soft: 0.5 - 2 / 0.5 - 2 N-m (4 - 18 / 4 - 18 in.lbs.)	Hard / Soft: 0.5 - 2 / 0.5 - 2 N-m (4 - 18 / 4 - 18 in.lbs.)	Hard / Soft: 1.5 - 6.5 / 1.5 - 6.5 N-m (13 - 58 / 13 - 58 in.lbs.)
Dimensions (L x W x H)	w/ BL1830B / BL1840B / BL1850B / BL1860B: 161 x 75 x 258 mm (6-3/8 x 2-15/16 x 10-1/8")	w/ BL1830B / BL1840B / BL1850B / BL1860B: 161 x 75 x 258 mm (6-3/8 x 2-15/16 x 10-1/8")	w/ BL1830B / BL1840B / BL1850B / BL1860B: 161 x 75 x 258 mm (6-3/8 x 2-15/16 x 10-1/8")
Net weight	1.2 - 1.5 kg (2.6 - 3.3 lbs.)	1.2 - 1.5 kg (2.6 - 3.3 lbs.)	1.2 - 1.5 kg (2.6 - 3.3 lbs.)

Cordless Screwdriver

18V



LXT BL MOTOR



	DFT087F	DFT129F
Driving shank (Hex)	6.35 mm (1/4")	6.35 mm (1/4")
No load speed	100 - 1,250 min ⁻¹	70 - 900 min ⁻¹
Fastening torque	Hard / Soft: 3 - 8 / 3 - 8 N-m (27 - 71 / 27 - 71 in.lbs.)	Hard / Soft: 5 - 12 / 5 - 12 N-m (44 - 106 / 44 - 106 in.lbs.)
Dimensions (L x W x H)	For products with specifications not compatible with HERUTU module, w/ BL1830B / BL1840B / BL1850B / BL1860B: 179 x 75 x 258 mm (7 x 2-15/16 x 10-1/8")	For products with specifications not compatible with HERUTU module, w/ BL1830B / BL1840B / BL1850B / BL1860B: 179 x 75 x 258 mm (7 x 2-15/16 x 10-1/8")
Net weight	1.3 - 1.6 kg (2.9 - 3.5 lbs.)	1.3 - 1.6 kg (2.9 - 3.5 lbs.)

Cordless Screwdriver

14.4V



LXT



	DFT043F	DFT083F	DFT125F
Driving shank (Hex)	6.35 mm (1/4")	6.35 mm (1/4")	6.35 mm (1/4")
No load speed	80 min ⁻¹	80 min ⁻¹	150 min ⁻¹
Fastening torque	Hard / Soft: 1 - 4 / 1 - 4 N-m (8.9 - 35 / 8.9 - 35 in.lbs.)	Hard / Soft: 3 - 8 / 3 - 8 N-m (27 - 71 / 27 - 71 in.lbs.)	Hard / Soft: 5 - 12 / 5 - 12 N-m (44 - 106 / 44 - 106 in.lbs.)
Dimensions (L x W x H)	200 x 72 x 255 mm (7-7/8 x 2-13/16 x 10")	200 x 72 x 255 mm (7-7/8 x 2-13/16 x 10")	200 x 72 x 255 mm (7-7/8 x 2-13/16 x 10")
Net weight	1.3 - 1.8 kg (2.9 - 4 lbs.)	1.3 - 1.8 kg (2.9 - 4 lbs.)	1.3 - 1.8 kg (2.9 - 4 lbs.)

Cordless Angle Screwdriver

18V

DFL126F



new

LXT BL MOTOR

DFL303F / DFL404F



	DFL126F	DFL303F	DFL404F
Driving shank (Square)	9.5 mm (3/8")	9.5 mm (3/8")	9.5 mm (3/8")
No load speed	75 - 1,000 min ⁻¹	50 - 420 min ⁻¹	50 - 310 min ⁻¹
Max rotation speed with guaranteed torque accuracy	-	230 min ⁻¹	220 min ⁻¹
Fastening torque	Hard / Soft: 5 - 12 / 5 - 12 N-m (44 - 106 / 44 - 106 in.lbs.)	Hard joint: 10 - 30 N-m (89 - 266 in.lbs.) Soft joint: 10 - 30 N-m (89 - 266 in.lbs.)	Hard joint: 20 - 40 N-m (177 - 354 in.lbs.) Soft joint: 20 - 40 N-m (177 - 354 in.lbs.)
Dimensions (L x W x H)	w/ BL1830B / BL1840B / BL1850B / BL1860B: 426 x 81 x 116 mm (16-3/4 x 3-3/16 x 4-9/16")	w/ BL1830B / BL1840B / BL1850B / BL1860B: 472 x 81 x 116 mm (18-5/8 x 3-3/16 x 4-9/16")	w/ BL1830B / BL1840B / BL1850B / BL1860B: 472 x 81 x 116 mm (18-5/8 x 3-3/16 x 4-9/16")
Net weight	1.7 - 2.0 kg (3.7 - 4.4 lbs.)	2.1 - 2.4 kg (4.6 - 5.3 lbs.)	2.1 - 2.4 kg (4.6 - 5.3 lbs.)

Cordless Angle Screwdriver

14.4V



LXT BL MOTOR



	DFL083F	DFL204F
Driving shank (Square)	9.5 mm (3/8")	9.5 mm (3/8")
No load speed	150 - 700 min ⁻¹	100 - 440 min ⁻¹
Fastening torque	Hard / Soft: 2 - 8 / 2 - 8 N-m (18 - 71 / 18 - 71 in.lbs.)	Hard / Soft: 8 - 20 / 8 - 20 N-m (71 - 177 / 71 - 177 in.lbs.)
Dimensions (L x W x H)	w/ BL1430(B) / BL1440 / BL1450 / BL1460B: 481 x 74 x 98 mm (19 x 2-15/16 x 3-7/8")	w/ BL1430(B) / BL1440 / BL1450 / BL1460B: 481 x 74 x 98 mm (19 x 2-15/16 x 3-7/8")
Net weight	1.7 - 2.1 kg (3.8 - 4.7 lbs.)	1.7 - 2.1 kg (3.8 - 4.7 lbs.)

Cordless Angle Screwdriver

18V

DFL020F / DFL063F



DFL651F

LXT BL MOTOR



	DFL020F	DFL063F	DFL651F
Driving shank (Square)	9.5 mm (3/8")	9.5 mm (3/8")	9.5 / 12.7 mm (3/8" / 1/2")
No load speed	100 - 1,300 min ⁻¹	180 - 1,300 min ⁻¹	80 - 200 min ⁻¹
Fastening torque	Hard / Soft: 0.5 - 2 / 0.5 - 2 N-m (4 - 18 / 4 - 18 in.lbs.)	Hard / Soft: 1.5 - 6.5 / 1.5 - 6.5 N-m (13 - 58 / 13 - 58 in.lbs.)	Hard / Soft: 25 - 65 / 25 - 65 N-m (220 - 580 / 220 - 580 in.lbs.)
Dimensions (L x W x H)	w/ BL1830B / BL1840B / BL1850B / BL1860B: 397 x 74 x 116 mm (15-5/8 x 2-5/16 x 4-9/16")	w/ BL1830B / BL1840B / BL1850B / BL1860B: 397 x 74 x 116 mm (15-5/8 x 2-5/16 x 4-9/16")	600 x 75 x 116 mm (23-5/8 x 2-15/16 x 4-9/16")
Net weight	1.3 - 1.6 kg (2.9 - 3.5 lbs.)	1.3 - 1.7 kg (2.9 - 3.8 lbs.)	2.5 - 2.9 kg (5.5 - 6.5 lbs.)

Cordless Tools for Industry

Cordless Angle Screwdriver

14.4V



LXT BL MOTOR TorqueTracer



	DFL201R	DFL301R	DFL402R
Driving shank (Square)	9.5 mm (3/8")	9.5 mm (3/8")	9.5 mm (3/8")
No load speed	360 min ⁻¹	260 min ⁻¹	200 min ⁻¹
Fastening torque	Hard / Soft: 10 - 20 / 10 - 20 N-m (88.5 - 177 / 88.5 - 177 in.lbs.)	Hard / Soft: 16 - 30 / 16 - 30 N-m (142 - 266 / 142 - 266 in.lbs.)	Hard / Soft: 25 - 40 / 25 - 40 N-m (221 - 354 / 221 - 354 in.lbs.)
Dimensions (L x W x H)	429 x 72 x 98 mm (16-7/8 x 2-13/16 x 3-7/8")	477 x 72 x 98 mm (18-3/4 x 2-13/16 x 3-7/8")	477 x 72 x 98 mm (18-3/4 x 2-13/16 x 3-7/8")
Net weight	1.5 - 1.9 kg (3.3 - 4.1 lbs.)	1.8 - 2.2 kg (4 - 4.8 lbs.)	1.8 - 2.2 kg (4 - 4.8 lbs.)

Cordless Screwdriver

14.4V



LXT BL MOTOR TorqueTracer



	DFT041R	DFT082R	DFT124R
Driving shank (Hex)	6.35 mm (1/4")	6.35 mm (1/4")	6.35 mm (1/4")
No load speed	800 min ⁻¹	860 min ⁻¹	600 min ⁻¹
Fastening torque	Hard / Soft: 1 - 4 / 1 - 4 N-m (8.9 - 35 / 8.9 - 35 in.lbs.)	Hard / Soft: 4 - 8 / 4 - 8 N-m (35 - 71 / 35 - 71 in.lbs.)	Hard / Soft: 6 - 12 / 6 - 12 N-m (53 - 106 / 53 - 106 in.lbs.)
Dimensions (L x W x H)	191 x 72 x 266 mm (7-1/2 x 2-13/16 x 10-1/2")	191 x 72 x 266 mm (7-1/2 x 2-13/16 x 10-1/2")	191 x 72 x 266 mm (7-1/2 x 2-13/16 x 10-1/2")
Net weight	1.3 - 1.8 kg (2.9 - 4 lbs.)	1.3 - 1.8 kg (2.9 - 4 lbs.)	1.3 - 1.8 kg (2.9 - 4 lbs.)

Cordless Impact Driver

14.4V



LXT BL MOTOR



	DTDA040	DTDA070	DTDA100	DTDA140
Capacity	Standard bolt: M5 - M10 (3/16 - 3/8") High strength bolt: M5 - M8 (3/16 - 5/16")	Standard bolt: M5 - M12 (3/16 - 1/2") High strength bolt: M5 - M10 (3/16 - 3/8")	Standard bolt: M5 - M12 (3/16 - 1/2") High strength bolt: M5 - M10 (3/16 - 3/8")	Standard bolt: M6 - M16 (1/4 - 5/8") High strength bolt: M6 - M12 (1/4 - 1/2")
Max fastening torque	35 N-m (310 in.lbs.)	65 N-m (575 in.lbs.)	95 N-m (840 in.lbs.)	140 N-m (1,240 in.lbs.)
No load speed	0 - 2,400 min ⁻¹	0 - 2,500 min ⁻¹	0 - 2,700 min ⁻¹	0 - 2,700 min ⁻¹
Impacts per minute	0 - 3,700 min ⁻¹	0 - 3,700 min ⁻¹	0 - 3,300 min ⁻¹	0 - 3,300 min ⁻¹
Dimensions (L x W x H)	w/ BL1430(B) / BL1440 / BL1450 / BL1460B: 139 x 74 x 256 mm (5-1/2 x 2-15/16 x 10-1/8")	w/ BL1430(B) / BL1440 / BL1450 / BL1460B: 139 x 74 x 256 mm (5-1/2 x 2-15/16 x 10-1/8")	w/ BL1430(B) / BL1440 / BL1450 / BL1460B: 146 x 74 x 256 mm (5-3/4 x 2-15/16 x 10-1/8")	w/ BL1430(B) / BL1440 / BL1450 / BL1460B: 146 x 74 x 256 mm (5-3/4 x 2-15/16 x 10-1/8")
Net weight	1.1 - 1.4 kg (2.4 - 3.1 lbs.)	1.1 - 1.4 kg (2.4 - 3.1 lbs.)	1.2 - 1.5 kg (2.7 - 3.3 lbs.)	1.2 - 1.5 kg (2.7 - 3.3 lbs.)

Cordless Impact Driver

14.4V



LXT



	DTD104	DTD064
Capacity	Machine screw: M4 - M8 (5/32 - 5/16") Standard bolt: M5 - M12 (3/16 - 1/2") High strength bolt: M5 - M10 (3/16 - 3/8")	Machine screw: M4 - M8 (5/32 - 5/16") Standard bolt: M5 - M10 (3/16 - 3/8") High strength bolt: M5 - M6 (3/16 - 1/4")
Max fastening torque	95 N-m (841 in.lbs.)	35 N-m (310 in.lbs.)
No load speed	0 - 2,700 min ⁻¹	0 - 2,500 min ⁻¹
Impacts per minute	0 - 3,500 min ⁻¹	0 - 3,500 min ⁻¹
Dimensions (L x W x H)	144 x 74 x 216 mm (5-5/8 x 2-15/16 x 8-1/2")	144 x 74 x 216 mm (5-5/8 x 2-15/16 x 8-1/2")
Net weight	1.1 - 1.3 kg (2.3 - 2.9 lbs.)	1 kg (2.3 lbs.)

Cordless Impact Driver

9.6V



	BTD040
Capacity	Machine screw: M4 - M8 (5/32 - 5/16") Standard bolt: M5 - M10 (3/16 - 3/8") High strength bolt: M5 - M8 (3/16 - 5/16")
Max fastening torque	40 N-m (354 in.lbs.)
No load speed	0 - 2,500 min ⁻¹
Impacts per minute	0 - 3,500 min ⁻¹
Overall length	164 mm (6-7/16")
Net weight	1.1 - 1.3 kg (2.4 - 2.8 lbs.)

Cordless Impact Driver

14.4V



LXT



	DTD033	DTD063	DTD043
Capacity	Machine screw: M4 - M8 (5/32 - 5/16") Standard bolt: M5 - M12 (3/16 - 1/2") High strength bolt: M5 - M10 (3/16 - 3/8")	Machine screw: M4 - M8 (5/32 - 5/16") Standard bolt: M5 - M12 (3/16 - 1/2") High strength bolt: M5 - M10 (3/16 - 3/8")	Machine screw: M4 - M8 (5/32 - 5/16") Standard bolt: M5 - M10 (3/16 - 3/8") High strength bolt: M5 - M6 (3/16 - 1/4")
Max fastening torque	95 N-m (841 in.lbs.)	65 N-m (575 in.lbs.)	35 N-m (310 in.lbs.)
No load speed	0 - 2,700 min ⁻¹	0 - 2,500 min ⁻¹	0 - 2,300 min ⁻¹
Impacts per minute	0 - 3,500 min ⁻¹	0 - 3,500 min ⁻¹	0 - 3,500 min ⁻¹
Dimensions (L x W x H)	144 x 74 x 216 mm (5-5/8 x 2-15/16 x 8-1/2")	144 x 74 x 216 mm (5-5/8 x 2-15/16 x 8-1/2")	144 x 74 x 216 mm (5-5/8 x 2-15/16 x 8-1/2")
Net weight	1 - 1.3 kg (2.3 - 2.8 lbs.)	1 - 1.3 kg (2.3 - 2.8 lbs.)	1 - 1.2 kg (2.2 - 2.7 lbs.)

Cordless Impact Driver

12V max



LXT BL MOTOR



	DTD112D
Capacity	Standard bolt: M5 - M14 (3/16 - 9/16") High strength bolt: M5 - M12 (3/16 - 1/2")
Max fastening torque	Hard / Soft: 135 N-m (1,200 in.lbs.) / 80 N-m (700 in.lbs.)
No load speed	Hard / Soft: 0 - 3,000 / 0 - 2,000 min ⁻¹
Impacts per minute	Hard / Soft: 0 - 3,900 / 0 - 3,300 min ⁻¹
Dimensions (L x W x H)	w/ BL1041B: 145 x 64 x 240 mm (5-3/4 x 2-1/2 x 9-1/2")
Net weight	0.99 - 1.2 kg (2.2 - 2.6 lbs.)

Cordless Impact Driver

10.8V



	TD091D
Capacity	Machine screw: M4 - M8 (5/32 - 5/16") Standard bolt: M5 - M12 (3/16 - 1/2") High strength bolt: M5 - M10 (3/16 - 3/8")
Max fastening torque	90 N·m (800 in.lbs.)
No load speed	0 - 2,400 min ⁻¹
Impacts per minute	0 - 3,000 min ⁻¹
Dimensions (L x W x H)	134 x 54 x 200 mm (5-1/4 x 2-1/8 x 7-7/8")
Net weight	0.86 kg (1.9 lbs.)

Cordless Impact Wrench

18V



	DTWA260
Square drive	12.7 mm (1/2")
Max fastening torque	260 N·m (190 ft.lbs.)
Capacity	Standard bolt: M14 - M20 (9/16 - 3/4") High strength bolt: M10 - M16 (3/8 - 5/8")
No load speed	0 - 2,800 min ⁻¹
Impacts per minute	0 - 3,400 min ⁻¹
Dimensions (L x W x H)	w/ BL1830B / BL1840B / BL1850B / BL1860B: 161 x 82 x 265 mm (6-3/8 x 3-1/4 x 10-3/8")
Net weight	1.8 kg (4.0 lbs.)

Cordless Impact Wrench

14.4V



	DTWA070	DTWA100	DTWA140	DTWA190
Square drive	9.5 mm (3/8")	9.5 mm (3/8")	12.7 mm (1/2")	12.7 mm (1/2")
Max fastening torque	65 N·m (48 ft.lbs.)	95 N·m (70 ft.lbs.)	140 N·m (103 ft.lbs.)	185 N·m (136 ft.lbs.)
Capacity	Standard bolt: M5 - M12 (3/16 - 1/2") High strength bolt: M5 - M10 (3/16 - 3/8")	Standard bolt: M5 - M12 (3/16 - 1/2") High strength bolt: M5 - M10 (3/16 - 3/8")	Standard bolt: M6 - M16 (1/4 - 5/8") High strength bolt: M6 - M12 (1/4 - 1/2")	Standard bolt: M8 - M16 (5/16 - 5/8") High strength bolt: M8 - M14 (5/16 - 9/16")
No load speed	0 - 2,500 min ⁻¹	0 - 2,700 min ⁻¹	0 - 2,700 min ⁻¹	0 - 2,600 min ⁻¹
Impacts per minute	0 - 3,700 min ⁻¹	0 - 3,300 min ⁻¹	0 - 3,300 min ⁻¹	0 - 3,000 min ⁻¹
Dimensions (L x W x H)	w/ BL1430(B) / BL1440 / BL1450 / BL1460B: 144 x 74 x 256 mm (5-5/8 x 2-15/16 x 10-1/8")	w/ BL1430(B) / BL1440 / BL1450 / BL1460B: 151 x 74 x 256 mm (5-15/16 x 2-15/16 x 10-1/8")	w/ BL1430(B) / BL1440 / BL1450 / BL1460B: 158 x 74 x 256 mm (6-1/4 x 2-15/16 x 10-1/8")	w/ BL1430(B) / BL1440 / BL1450 / BL1460B: 158 x 74 x 256 mm (6-1/4 x 2-15/16 x 10-1/8")
Net weight	1.1 - 1.4 kg (2.4 - 3.1 lbs.)	1.2 - 1.5 kg (2.7 - 3.3 lbs.)	1.2 - 1.5 kg (2.7 - 3.3 lbs.)	1.3 - 1.6 kg (2.9 - 3.5 lbs.)

Cordless Impact Wrench

14.4V



	DTW104	DTW074
Square drive	9.5 mm (3/8")	9.5 mm (3/8")
Max fastening torque	95 N·m (841 in.lbs.)	65 N·m (575 in.lbs.)
Capacity	Standard bolt: M5 - M12 (3/16 - 1/2") High strength bolt: M5 - M10 (3/16 - 3/8")	Standard bolt: M5 - M12 (3/16 - 1/2") High strength bolt: M5 - M10 (3/16 - 3/8")
No load speed	0 - 2,700 min ⁻¹	0 - 2,500 min ⁻¹
Impacts per minute	0 - 3,500 min ⁻¹	0 - 3,500 min ⁻¹
Dimensions (L x W x H)	w/ BL1430(B) / BL1440 / BL1450 / BL1460B: 144 x 74 x 234 mm (5-5/8 x 2-15/16 x 9-1/4")	144 x 74 x 216 mm (5-5/8 x 2-15/16 x 8-1/2")
Net weight	1.1 kg (2.4 lbs.)	1.1 - 1.3 kg (2.3 - 2.9 lbs.)

Cordless Impact Wrench

14.4V





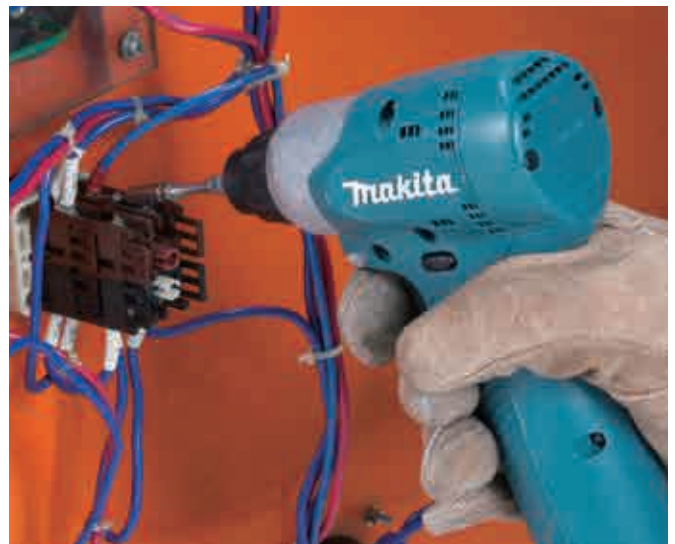





	DTW103	DTW073
Max fastening torque	95 N·m (841 in.lbs.)	65 N·m (575 in.lbs.)
Capacity	Standard bolt: M5 - M12 (3/16 - 1/2") High strength bolt: M5 - M10 (3/16 - 3/8")	Standard bolt: M5 - M12 (3/16 - 1/2") High strength bolt: M5 - M10 (3/16 - 3/8")
No load speed	0 - 2,700 min ⁻¹	0 - 2,500 min ⁻¹
Impacts per minute	0 - 3,500 min ⁻¹	0 - 3,500 min ⁻¹
Dimensions (L x W x H)	144 x 74 x 216 mm (5-5/8 x 2-15/16 x 8-1/2")	144 x 74 x 216 mm (5-5/8 x 2-15/16 x 8-1/2")
Net weight	1 - 1.3 kg (2.3 - 2.8 lbs.)	1.3 - 1.6 kg (2.9 - 3.5 lbs.)



PRODUCTS

Stirring



-  Double Insulation
-  Variable Speed
-  Anti-restart function
-  Mechanical 2-Speed
-  Electronic 2-Speed
-  Constant Speed
-  Soft Start
-  Carrying Case

Cordless Concrete Vibrator VR001G

40V max



Vibrations per minute	Power mode: 15,500 min ⁻¹ Normal mode: 12,000 min ⁻¹
Work amount on a full battery charge	w/ 28mm - 0.8m shaft, w/ BL4040, Power mode: 45 min w/ 28mm - 0.8m shaft, w/ BL4040, Normal mode: 60 min
Dimensions (L x W x H)	w/o Flexible shaft, w/ BL4050F/ BL4080F and Battery case L set: 296 x 112 x 299 mm (11-5/8 x 4-3/8 x 11-3/4")
Net weight	4.8 - 7.8 kg (10.6 - 17.2 lbs.)



Cordless Concrete Vibrator VR003G

40V max



Vibrator diameter	32 mm (1-1/4")
Flexible shaft length	1.2, 1.7, 2.4 m (3.9, 5.6, 7.9 ft)
Vibrations per minute	Power mode: 15,500 min ⁻¹ Normal mode: 12,000 min ⁻¹
Work amount on a full battery charge	w/ 28mm - 0.8m shaft, w/ BL4040, Power mode: 45 min w/ 28mm - 0.8m shaft, w/ BL4040, Normal mode: 60 min
Dimensions (L x W x H)	w/o Flexible shaft, w/ BL4050F/ BL4080F and Battery case L set: 296 x 112 x 299 mm (11-5/8 x 4-3/8 x 11-3/4")
Net weight	4.8 - 7.8 kg (10.6 - 17.2 lbs.)



Cordless Concrete Vibrator VR004G

40V max



Vibrator diameter	38 mm (1-1/2")
Flexible shaft length	1.2, 2.4 m (3.9, 7.9 ft)
Vibrations per minute	Power mode: 15,500 min ⁻¹ Normal mode: 12,000 min ⁻¹
Work amount on a full battery charge	w/ 28mm - 0.8m shaft, w/ BL4040, Power mode: 45 min w/ 28mm - 0.8m shaft, w/ BL4040, Normal mode: 60 min
Dimensions (L x W x H)	w/o Flexible shaft, w/ BL4050F/ BL4080F and Battery case L set: 296 x 112 x 299 mm (11-5/8 x 4-3/8 x 11-3/4")
Net weight	4.8 - 7.8 kg (10.6 - 17.2 lbs.)



Cordless Concrete Vibrator DVR850

18V



Vibrator diameter	25 mm (1")
Flexible shaft length	2,400 mm (8 ft)
Vibrations per minute	12,500 min ⁻¹
Dimensions (L x W x H)	2,683 x 93 x 250 mm (105-1/2 x 3-5/8 x 9-7/8")
Net weight	4.5 - 5.5 kg (9.9 - 12 lbs.)



Cordless Concrete Vibrator DVR450

18V



Vibrator diameter	25 mm (1")
Flexible shaft length	1,200 mm (4.0 ft)
Vibrations per minute	13,000 min ⁻¹
Dimensions (L x W x H)	1,483 x 93 x 250 mm (58-1/2 x 3-5/8 x 9-7/8")
Net weight	3.3 - 3.8 kg (7.3 - 8.3 lbs.)



Cordless Concrete Vibrator DVR350

18V



Vibrator diameter	25 mm (1")
Flexible shaft length	800 mm (2.6 ft)
Vibrations per minute	13,000 min ⁻¹
Dimensions (L x W x H)	1,083 x 93 x 250 mm (42-3/4 x 3-5/8 x 9-7/8")
Net weight	2.9 - 3.3 kg (6.5 - 7.4 lbs.)



Battery Powered Concrete Vibrator VR001C

40V max



Vibrator diameter	43 mm (1-11/16")
Flexible shaft length	1.5 m (4.9 ft)
Vibrations per minute	12,000 min ⁻¹
Continuous run time on full battery charge	w/ PDC01 (BL1860B x4): 100 min. w/ PDC1200: 300 min.
Net weight	w/ PDC01 (BL1860B x4): 11.8 kg (26.0 lbs.)

Battery Powered Concrete Vibrator VR002C

40V max



Vibrator diameter	43 mm (1-11/16")
Flexible shaft length	3.0 m (9.8 ft)
Vibrations per minute	12,000 min ⁻¹
Continuous run time on full battery charge	w/ PDC01 (BL1860B x4): 100 min. w/ PDC1200: 300 min.
Net weight	w/ PDC01 (BL1860B x4): 12.9 kg (28.4 lbs.)

Battery Powered Concrete Vibrator VR003C

40V max



Vibrator diameter	52 mm (2")
Flexible shaft length	1.5 m (4.9 ft)
Vibrations per minute	12,000 min ⁻¹
Continuous run time on full battery charge	w/ PDC01 (BL1860B x4): 60 min. w/ PDC1200: 200 min.
Net weight	w/ PDC01 (BL1860B x4): 12.6 kg (27.8 lbs.)

Battery Powered Concrete Vibrator VR004C

40V max



Vibrator diameter	52 mm (2")
Flexible shaft length	3.0 m (9.8 ft)
Vibrations per minute	12,000 min ⁻¹
Continuous run time on full battery charge	w/ PDC01 (BL1860B x4): 60 min. w/ PDC1200: 200 min.
Net weight	w/ PDC01 (BL1860B x4): 13.7 kg (30.2 lbs.)

Stirring

Cordless Mixer
UT001G

40V max



Blade diameter	240 mm (9-1/2")
No load speed	High / Low: 0 - 920 / 0 - 500 min ⁻¹
Dimensions (L x W x H)	w/ Cover L, w/ BL4050F / BL4080F: 414 x 458 x 235 mm (16-1/4 x 18 x 9-1/4")
Net weight	5.7 - 7.0 kg (12.6 - 15.4 lbs.)

XGT BL MOTOR XPT

Cordless Mixer
UT002G

40V max



Blade diameter	240 mm (9-1/2")
Chuck capacity	13 mm (1/2")
No load speed	High / Low: 0 - 920 / 0 - 500 min ⁻¹
Dimensions (L x W x H)	w/ Cover L, w/ BL4050F / BL4080F: 404 x 458 x 235 mm (15-7/8 x 18 x 9-1/4")
Net weight	5.8 - 7.2 kg (12.8 - 15.9 lbs.)

XGT BL MOTOR XPT

Cordless Mixer
DUT130

18V



Blade diameter	165 mm (6-1/2")
Shank size of tool holder portion	M12 or M14
No load speed	High / Low: 0 - 1,300 / 0 - 350 min ⁻¹
Dimensions (L x W x H)	w/ Mixing blade: 916 x 89 x 231 mm (36 x 3-1/2 x 9-1/8")
Net weight	2.5 - 2.8 kg (5.6 - 6.3 lbs.)

LXI BL MOTOR XPT

Cordless Mixer
DUT131

18V



Chuck capacity	1.5 - 13 mm (1/16 - 1/2")
No load speed	High / Low: 0 - 1,300 / 0 - 350 min ⁻¹
Dimensions (L x W x H)	307 x 89 x 231 mm (12-1/8 x 3-1/2 x 9-1/8")
Net weight	2.7 - 3.0 kg (5.8 - 6.6 lbs.)

LXI BL MOTOR XPT

Mixer
UT2204

Continuous rating	850W
Input	
Blade diameter	220 mm (8-5/8")
No Load Speed	550 min ⁻¹
Shank size of tool holder portion	M12 or M14
Dimensions (L x W x H)	929 x 89 x 152 mm (36-1/2 x 3-1/2 x 6")
Net weight	2.7 kg (5.9 lbs.)

Mixer
UT1305

Continuous rating	850W
Input	
Blade diameter	165 mm (6-1/2")
No Load Speed	1,300 min ⁻¹
Shank size of tool holder portion	M12
Dimensions (L x W x H)	942 x 87 x 152 mm (37 x 3-7/16 x 6")
Net weight	2.6 kg (5.7 lbs.)

Power Mixer
UT1600

Continuous rating	1,800W
Input	
Mixing capacity	90 kg
Blade diameter	180 mm (7-1/8")
No load speed	High / Low: 0 - 970 / 0 - 440 min ⁻¹
Dimensions (L x W x H)	430 x 180 x 349 mm (17 x 7-1/8 x 13-3/4")
Net weight	7.1 kg (15.7 lbs.)

Power Mixer
UT1401

Continuous rating	1,300W
Input	
Mixing capacity	60 kg
Blade diameter	140 mm (5-1/2")
No load speed	High / Low: 0 - 730 / 0 - 400 min ⁻¹
Dimensions (L x W x H)	430 x 180 x 349 mm (17 x 7-1/8 x 13-3/4")
Net weight	5.5 kg (12.1 lbs.)

Power Mixer
UT1400

Continuous rating	1,300W
Input	
Mixing capacity	50 kg
Blade diameter	140 mm (5-1/2")
No load speed	0 - 900 min ⁻¹
Dimensions (L x W x H)	430 x 180 x 305 mm (17 x 7-1/8 x 12")
Net weight	5.2 kg (11.5 lbs.)

Power Mixer
UT1200

















Continuous rating	960W
Input	
Mixing capacity	40 kg
Blade diameter	120 mm (4-3/4")
No load speed	0 - 590 min ⁻¹
Dimensions (L x W x H)	345 x 180 x 295 mm (13-5/8 x 7-1/8 x 11-5/8")
Net weight	3.2 kg (7 lbs.)



PRODUCTS

Hammer drilling/Chiselling



-  Double Insulation
-  Variable Speed
-  Brake
-  Reversing
-  Anti-restart function
-  Mechanical 2-Speed
-  Keyless Chuck
-  Adapted for SDS-MAX bits
-  Adapted for SDS-PLUS bits
-  17mm Hex Shank
-  19mm Hex Shank
-  21mm Hex Shank
-  28.6mm Hex Shank
-  30mm Hex Shank
-  Spline Shank
-  Torque Limiter
-  Constant Speed
-  Soft Start
-  Dust Collection
-  Built-in Job Light
-  Carrying Case

Hammer drilling/Chiselling

Cordless Rotary Hammer HR006G

40V max x2



Blows per minute	1,100 - 2,250 min ⁻¹
No load speed	150 - 310 min ⁻¹
Capacity	Concrete (w/ TCT bit): 52 mm (2-1/16")
Impact energy	EPTA-Procedure 05/2009: 21.4 J
Dimensions (L x W x H)	w/ BL4040: 610 x 140 x 337 mm (24 x 5-1/2 x 13-1/4")
Net weight	12.9 - 14.3 kg (28.4 - 31.5 lbs.)

XGT BL MOTOR AFT AVT AWS SOFT NOLOAD XPT



Cordless Rotary Hammer HR005G

40V max



Blows per minute	1,450 - 2,900 min ⁻¹
No load speed	250 - 500 min ⁻¹
Capacity	Concrete (w/ TCT bit): 40 mm (1-9/16")
Impact energy	EPTA-Procedure 05/2009: 8 J
Dimensions (L x W x H)	w/ BL4050F: 520 x 115 x 305 mm (20-1/2 x 4-1/2 x 12")
Net weight	7.4 - 8.2 kg (16.3 - 18.1 lbs.)

XGT BL MOTOR AFT AVT AWS SOFT NOLOAD XPT



Cordless Combination Hammer HR009G

40V max



Blows per minute	0 - 4,500 min ⁻¹
No load speed	0 - 840 min ⁻¹
Capacity	Concrete: 30 mm (1-3/16") Concrete (w/ TCT bit): 30 mm (1-3/16") Steel: 13 mm (1/2") Wood: 32 mm (1-1/4")
Impact energy	EPTA-Procedure 05/2009: 3.9 J (2.9 ft.lbs.)
Chuck capacity	1.5 - 13 mm (1/16 - 1/2")
Dimensions (L x W x H)	w/ BL4080F: 457 x 97 x 282 mm (18 x 3-13/16 x 11-1/8")
Net weight	5.3 - 6.7 kg (11.7 - 14.8 lbs.)

XGT BL MOTOR AFT AVT AWS XPT



Quick change drill chuck

Cordless Combination Hammer HR008G

40V max



Blows per minute	0 - 4,500 min ⁻¹
No load speed	0 - 840 min ⁻¹
Capacity	Concrete: 30 mm (1-3/16") Concrete (w/ TCT bit): 30 mm (1-3/16") Steel: 13 mm (1/2") Wood: 32 mm (1-1/4")
Impact energy	EPTA-Procedure 05/2009: 3.9 J (2.9 ft.lbs.)
Dimensions (L x W x H)	w/ BL4080F: 441 x 97 x 282 mm (17-3/8 x 3-13/16 x 11-1/8")
Net weight	5.2 - 6.8 kg (11.5 - 15.0 lbs.)

XGT BL MOTOR AFT AVT AWS XPT



Dust Collection System DX11 / DX10

DX11
model: HR009G / HR3012FC



DX10
model: HR008G / HR3011FC



HEPA
filter

Cordless Combination Hammer HR007G

40V max



Blows per minute	0 - 5,000 min ⁻¹
No load speed	0 - 980 min ⁻¹
Capacity	Concrete: 28 mm (1-1/8") Masonry: 28 mm (1-1/8") Steel: 13 mm (1/2") Wood: 32 mm (1-1/4")
Impact energy	EPTA-Procedure 05/2009: 3.0 J (2.2 ft.lbs.)
Dimensions (L x W x H)	w/ BL4050F: 492 x 101 x 261 mm (19-3/8 x 4 x 10-1/4")
Net weight	3.8 - 4.8 kg (8.4 - 10.6 lbs.)

XGT BL MOTOR AFT AVT AWS XPT



Dust Collection System DX15

DX15
model: HR007G



HEPA
filter

Cordless Combination Hammer HR002G

40V max



Blows per minute	0 - 5,000 min ⁻¹
No load speed	0 - 980 min ⁻¹
Capacity	Concrete: 28 mm (1-1/8") Masonry: 28 mm (1-1/8") Steel: 13 mm (1/2") Wood: 32 mm (1-1/4") Wood (Self-feed bit): 32 mm (1-1/4")
Impact energy	EPTA-Procedure 05/2009: 2.9 J (2.1 ft.lbs.)
Chuck capacity	1.5 - 13 mm (1/16 - 1/2")
Dimensions (L x W x H)	w/ BL4040: 404 x 102 x 238 mm (15-7/8 x 4 x 9-3/8")
Net weight	4.1 - 4.6 kg (9.0 - 10.1 lbs.)

XGT BL MOTOR AFT AVT AWS SOFT NOLOAD XPT



Quick change drill chuck

Cordless Combination Hammer HR001G

40V max



Blows per minute	0 - 5,000 min ⁻¹
No load speed	0 - 980 min ⁻¹
Capacity	Concrete: 28 mm (1-1/8") Masonry: 28 mm (1-1/8") Steel: 13 mm (1/2") Wood: 32 mm (1-1/4") Wood (Self-feed bit): 32 mm (1-1/4")
Impact energy	EPTA-Procedure 05/2009: 2.8 J (2.1 ft.lbs.)
Chuck capacity	1.5 - 13 mm (1/16 - 1/2")
Dimensions (L x W x H)	w/ BL4040: 373 x 102 x 238 mm (14-3/4 x 4 x 9-3/8")
Net weight	3.9 - 4.6 kg (8.6 - 10.1 lbs.)

XGT BL MOTOR AFT AVT AWS SOFT NOLOAD XPT



Cordless Combination Hammer HR004G

40V max



Blows per minute	0 - 5,000 min ⁻¹
No load speed	0 - 980 min ⁻¹
Capacity	Concrete: 28 mm (1-1/8") Masonry: 28 mm (1-1/8") Steel: 13 mm (1/2") Wood: 32 mm (1-1/4") Wood (Self-feed bit): 32 mm (1-1/4")
Impact energy	EPTA-Procedure 05/2009: 2.9 J (2.1 ft.lbs.)
Chuck capacity	1.5 - 13 mm (1/16 - 1/2")
Dimensions (L x W x H)	w/ BL4040: 404 x 102 x 238 mm (15-7/8 x 4 x 9-3/8")
Net weight	4.0 - 4.5 kg (8.8 - 9.9 lbs.)

XGT BL MOTOR AFT XPT



Quick change drill chuck

Hammer drilling/Chiselling

Hammer drilling/Chiselling

Cordless Combination Hammer HR003G

40V max



Blows per minute	0 - 5,000 min ⁻¹
No load speed	0 - 980 min ⁻¹
Capacity	Concrete: 28 mm (1-1/8") Masonry: 28 mm (1-1/8") Steel: 13 mm (1/2") Wood: 32 mm (1-1/4") Wood (Self-feed bit): 32 mm (1-1/4")
Impact energy	EPTA-Procedure 05/2009: 2.8 J (2.1 ft.lbs.)
Chuck capacity	1.5 - 13 mm (1/16 - 1/2")
Dimensions (L x W x H)	w/ BL4040: 373 x 102 x 238 mm (14-3/4 x 4 x 9-3/8")
Net weight	3.9 - 4.6 kg (8.6 - 10.1 lbs.)



Dust Collection System DX12 / DX14

DX12 model: HR001G / HR003G

DX14 model: HR002G / HR004G



HEPA filter

Cordless Combination Hammer HR010G

40V max



Blows per minute	0 - 5,000 min ⁻¹
No load speed	0 - 1,350 min ⁻¹
Capacity	Concrete (w/ TCT bit): 20 mm (13/16") Steel: 13 mm (1/2") Wood: 26 mm (1")
Impact energy	EPTA-Procedure 05/2009: 2.1 J
Dimensions (L x W x H)	w/ BL4020 / BL4025: 289 x 93 x 217 mm (11-3/8 x 3-5/8 x 8-1/2")
Net weight	2.8 - 4.5 kg (6.2 - 9.9 lbs.)



Dust Collection System DX16

DX16 model: HR010G / DHR183



HEPA filter

Cordless Rotary Hammer DHR400

18V x2



Blows per minute	1,450 - 2,900 min ⁻¹
No load speed	250 - 500 min ⁻¹
Capacity	Concrete (w/ TCT bit): 40 mm (1-9/16") Masonry: 40 mm (1-9/16")
Impact energy	EPTA-Procedure 05/2009: 8 J
Dimensions (L x W x H)	473 x 120 x 285 mm (18-5/8 x 4-3/4 x 11-1/4")
Net weight	7.3 - 8.1 kg (16.1 - 17.9 lbs.)



Cordless Combination Hammer DHR283

18V x2



Quick change drill chuck

Blows per minute	0 - 5,000 min ⁻¹
No load speed	0 - 980 min ⁻¹
Capacity	Concrete: 28 mm (1-1/8") Masonry: 28 mm (1-1/8") Steel: 13 mm (1/2") Wood: 32 mm (1-1/4") Wood (Self-feed bit): 32 mm (1-1/4")
Impact energy	EPTA-Procedure 05/2009: 2.9 J (2.1 ft.lbs.)
Chuck capacity	1.5 - 13 mm (1/16 - 1/2")
Dimensions (L x W x H)	404 x 134 x 232 mm (15-7/8 x 5-1/4 x 9-1/8")
Net weight	4.0 - 4.9 kg (8.8 - 10.8 lbs.)



Cordless Combination Hammer DHR282

18V x2



Blows per minute	0 - 5,000 min ⁻¹
No load speed	0 - 980 min ⁻¹
Capacity	Concrete: 28 mm (1-1/8") Masonry: 28 mm (1-1/8") Steel: 13 mm (1/2") Wood: 32 mm (1-1/4") Wood (Self-feed bit): 32 mm (1-1/4")
Impact energy	EPTA-Procedure 05/2009: 2.8 J (2.1 ft.lbs.)
Chuck capacity	1.5 - 13 mm (1/16 - 1/2")
Dimensions (L x W x H)	373 x 134 x 232 mm (14-3/4 x 5-1/4 x 9-1/8")
Net weight	3.9 - 5.0 kg (8.6 - 11.0 lbs.)



Cordless Combination Hammer DHR281

18V x2



Quick change drill chuck

Blows per minute	0 - 5,000 min ⁻¹
No load speed	0 - 980 min ⁻¹
Capacity	Concrete: 28 mm (1-1/8") Masonry: 28 mm (1-1/8") Steel: 13 mm (1/2") Wood: 32 mm (1-1/4") Wood (Self-feed bit): 32 mm (1-1/4")
Impact energy	EPTA-Procedure 05/2009: 2.9 J (2.1 ft.lbs.)
Chuck capacity	1.5 - 13 mm (1/16 - 1/2")
Dimensions (L x W x H)	404 x 134 x 232 mm (15-7/8 x 5-1/4 x 9-1/8")
Net weight	4.0 - 4.9 kg (8.8 - 10.8 lbs.)



Cordless Combination Hammer DHR280

18V x2



Blows per minute	0 - 5,000 min ⁻¹
No load speed	0 - 980 min ⁻¹
Capacity	Concrete: 28 mm (1-1/8") Masonry: 28 mm (1-1/8") Steel: 13 mm (1/2") Wood: 32 mm (1-1/4") Wood (Self-feed bit): 32 mm (1-1/4")
Impact energy	EPTA-Procedure 05/2009: 2.8 J (2.1 ft.lbs.)
Chuck capacity	1.5 - 13 mm (1/16 - 1/2")
Dimensions (L x W x H)	373 x 134 x 232 mm (14-3/4 x 5-1/4 x 9-1/8")
Net weight	3.8 - 4.9 kg (8.4 - 10.8 lbs.)



Dust Extraction System DX08 / DX09

DX08 model: DHR283 / DHR281

DX19 model: DHR282 / DHR280



HEPA filter

Hammer drilling/Chiselling

Cordless Combination Hammer DHR264

18V x2



Quick change drill chuck

Blows per minute	0 - 5,000 min ⁻¹
No load speed	0 - 1,250 min ⁻¹
Capacity	Concrete: 26 mm (1") Masonry: 26 mm (1") Steel: 13 mm (1/2") Wood: 32 mm (1-1/4") Wood (Self-feed bit): 32 mm (1-1/4")
Impact energy	EPTA-Procedure 05/2009: 2.5 J (1.8 ft.lbs.)
Chuck capacity	1.5 - 13 mm (1/16 - 1/2")
Dimensions (L x W x H)	374 x 116 x 232 mm (14-3/4 x 4-9/16 x 9-1/8")
Net weight	4.2 - 5.1 kg (9.2 - 11.2 lbs.)

LXI XPT



Cordless Combination Hammer DHR263

18V x2



Blows per minute	0 - 5,000 min ⁻¹
No load speed	0 - 1,250 min ⁻¹
Capacity	Concrete: 26 mm (1") Masonry: 26 mm (1") Steel: 13 mm (1/2") Wood: 32 mm (1-1/4") Wood (Self-feed bit): 32 mm (1-1/4")
Impact energy	EPTA-Procedure 05/2009: 2.5 J (1.8 ft.lbs.)
Chuck capacity	1.5 - 13 mm (1/16 - 1/2")
Dimensions (L x W x H)	350 x 116 x 232 mm (13-3/4 x 4-9/16 x 9-1/8")
Net weight	4.1 - 5.1 kg (9 - 11.3 lbs.)

LXI XPT



Cordless Combination Hammer DHR243

18V



Quick change drill chuck

Blows per minute	0 - 4,700 min ⁻¹
No load speed	0 - 950 min ⁻¹
Capacity	Concrete: 24 mm (15/16") Masonry: 24 mm (15/16") Steel: 13 mm (1/2") Wood: 27 mm (1-1/16") Wood (Self-feed bit): 27 mm (1-1/16")
Impact energy	2 J
Chuck capacity	1.5 - 13 mm (1/16 - 1/2")
Dimensions (L x W x H)	353 x 85 x 213 mm (13-7/8 x 3-3/8 x 8-3/8")
Net weight	3.2 - 3.7 kg (6.9 - 8.3 lbs.)

LXI BL MOTOR XPT



Cordless Combination Hammer DHR242

18V



Blows per minute	0 - 4,700 min ⁻¹
No load speed	0 - 950 min ⁻¹
Capacity	Concrete: 24 mm (15/16") Masonry: 24 mm (15/16") Steel: 13 mm (1/2") Wood: 27 mm (1-1/16") Wood (Self-feed bit): 27 mm (1-1/16")
Impact energy	2 J
Chuck capacity	1.5 - 13 mm (1/16 - 1/2")
Dimensions (L x W x H)	328 x 85 x 213 mm (12-7/8 x 3-3/8 x 8-3/8")
Net weight	3.1 - 3.8 kg (6.7 - 8.4 lbs.)

LXI BL MOTOR XPT



Cordless Combination Hammer DHR241

18V



Blows per minute	0 - 4,000 min ⁻¹
No load speed	0 - 1,100 min ⁻¹
Capacity	Concrete: 20 mm (13/16") Masonry: 20 mm (13/16") Steel: 13 mm (1/2") Wood: 26 mm (1") Wood (Self-feed bit): 26 mm (1")
Impact energy	1.9 J
Chuck capacity	1.5 - 13 mm (1/16 - 1/2")
Dimensions (L x W x H)	417 x 84 x 219 mm (16-3/8 x 3-5/16 x 8-5/8")
Net weight	3.2 - 4 kg (7.1 - 8.8 lbs.)

LXI



Cordless Combination Hammer DHR202

18V



Blows per minute	0 - 4,000 min ⁻¹
No load speed	0 - 1,100 min ⁻¹
Capacity	Concrete: 20 mm (13/16") Masonry: 20 mm (13/16") Steel: 13 mm (1/2") Wood: 26 mm (1") Wood (Self-feed bit): 26 mm (1")
Impact energy	EPTA-Procedure 05/2009: 2.0 J (1.5 ft.lbs.)
Chuck capacity	1.5 - 13 mm (1/16 - 1/2")
Dimensions (L x W x H)	358 x 84 x 259 mm (14-1/8 x 3-5/16 x 10-1/4")
Net weight	3.2 - 4 kg (7.1 - 8.8 lbs.)

LXI



Cordless Rotary Hammer DHR183

18V



Blows per minute	0 - 5,000 min ⁻¹
No load speed	0 - 1,100 min ⁻¹
Capacity	Concrete: 18 mm (11/16") Steel: 13 mm (1/2") Wood: 24 mm (15/16")
Impact energy	EPTA-Procedure 05/2009: 1.7 J
Dimensions (L x W x H)	w/ BL1830B / BL1840B / BL1850B / BL1860B: 288 x 89 x 215 mm (11-3/8 x 3-1/2 x 8-1/2")
Net weight	2.1 - 2.9 kg (4.6 - 6.4 lbs.)

LXI BL MOTOR AVT XPT



Cordless Combination Hammer DHR182

18V



Blows per minute	0 - 5,000 min ⁻¹
No load speed	0 - 1,350 min ⁻¹
Capacity	Concrete: 18 mm (11/16") Masonry: 18 mm (11/16") Steel: 13 mm (1/2") Wood: 24 mm (15/16")
Impact energy	EPTA-Procedure 05/2009: 1.7 J (1.3 ft.lbs.)
Chuck capacity	1.5 - 13 mm (1/16 - 1/2")
Dimensions (L x W x H)	w/ BL1830B / BL1840B / BL1850B / BL1860B: 301 x 82 x 285 mm (11-7/8 x 3-1/4 x 11-1/4")
Net weight	2.4 - 3.2 kg (5.3 - 7.0 lbs.)

LXI BL MOTOR AVT AWS XPT



Cordless Rotary Hammer DHR171

18V



Blows per minute	0 - 4,800 min ⁻¹
No load speed	0 - 680 min ⁻¹
Capacity	Concrete: 17 mm (11/16") Masonry: 17 mm (11/16") Steel: 10 mm (3/8") Wood: 13 mm (1/2")
Impact energy	EPTA-Procedure 05/2009: 1.2 J
Chuck capacity	1.5 - 13 mm (1/16 - 1/2")
Dimensions (L x W x H)	w/ BL1830B / BL1840B / BL1850B / BL1860B: 273 x 86 x 211 mm (10-3/4 x 3-3/8 x 8-5/16")
Net weight	2.1 - 2.8 kg (4.6 - 6.2 lbs.)

LXI BL MOTOR



Cordless Rotary Hammer DHR165

18V



Blows per minute	0 - 5,300 min ⁻¹
No load speed	0 - 1,600 min ⁻¹
Capacity	Concrete (w/ TCT bit): 16 mm (5/8") Masonry: 16 mm (5/8") Steel: 13 mm (1/2") Wood: 24 mm (15/16")
Impact energy	1.3 J
Chuck capacity	1.5 - 13 mm (1/16 - 1/2")
Dimensions (L x W x H)	297 x 79 x 253 mm (11-3/4 x 3-1/8 x 10")
Net weight	2.3 - 3 kg (5 - 6.6 lbs.)

LXI XPT



Hammer drilling/Chiselling

Cordless Rotary Hammer HR166D

12V max



Blows per minute	0 - 4,800 min ⁻¹
No load speed	0 - 680 min ⁻¹
Capacity	Concrete: 16 mm (5/8") Masonry: 16 mm (5/8") Steel: 10 mm (3/8") Wood: 13 mm (1/2")
Impact energy	EPTA-Procedure 05/2009: 1.1 J
Chuck capacity	1.5 - 13 mm (1/16 - 1/2")
Dimensions (L x W x H)	w/ BL1041B: 250 x 74 x 206 mm (9-7/8 x 2-15/16 x 8-1/8")
Net weight	1.8 - 2.4 kg (4.1 - 5.4 lbs.)



Cordless Rotary Hammer HR140D

12V max



Impacts per minute	0 - 4,900 min ⁻¹
No load speed	0 - 850 min ⁻¹
Capacity	Concrete: 14 mm (9/16") Masonry: 14 mm (9/16") Steel: 10 mm (3/8") Wood: 13 mm (1/2")
Impact energy	EPTA-Procedure 05/2009: 1.0 J
Chuck capacity	1.5 - 13 mm (1/16 - 1/2")
Dimensions (L x W x H)	w/ BL1041B: 246 x 74 x 198 mm (9-11/16 x 2-15/16 x 7-3/4")
Net weight	1.9 - 2.6 kg (4.3 - 5.6 lbs.)



Rotary Hammer HR5212C



Continuous rating	1,510W
Input	
Blows per minute	1,100 - 2,250 min ⁻¹
No load speed	150 - 310 min ⁻¹
Capacity	Concrete (w/ TCT bit): 52 mm (2") Masonry: 52 mm (2")
Impact energy	EPTA-Procedure 05/2009: 20 J
Dimensions (L x W x H)	599 x 140 x 287 mm (23-1/2 x 5-1/2 x 11-1/4")
Net weight	11.9 - 12 kg (26.2 - 26.5 lbs.)



Rotary Hammer HR5202C



Continuous rating	1,510W
Input	
Blows per minute	1,100 - 2,250 min ⁻¹
No load speed	150 - 310 min ⁻¹
Capacity	Concrete (w/ TCT bit): 52 mm (2") Masonry: 52 mm (2")
Impact energy	EPTA-Procedure 05/2009: 19.1 J
Dimensions (L x W x H)	599 x 134 x 287 mm (23-1/2 x 5-1/4 x 11-1/4")
Net weight	10.9 - 11.1 kg (24.1 - 24.4 lbs.)



Rotary Hammer HR4511C



Continuous rating	1,350W
Input	
Blows per minute	1,250 - 2,750 min ⁻¹
No load speed	130 - 280 min ⁻¹
Capacity	Concrete (w/ TCT bit): 45 mm (1-3/4") Masonry: 45 mm (1-3/4")
Impact energy	EPTA-Procedure 05/2009: 9.4 J
Dimensions (L x W x H)	458 x 136 x 288 mm (18 x 5-3/8 x 11-3/8")
Net weight	9 - 9.1 kg (19.8 - 20.1 lbs.)



Rotary Hammer HR4510C



Continuous rating	1,350W
Input	
Blows per minute	1,250 - 2,750 min ⁻¹
No load speed	130 - 280 min ⁻¹
Capacity	Concrete (w/ TCT bit): 45 mm (1-3/4") Masonry: 45 mm (1-3/4")
Impact energy	EPTA-Procedure 05/2009: 9.4 J
Dimensions (L x W x H)	458 x 136 x 288 mm (18 x 5-3/8 x 11-3/8")
Net weight	8.9 - 9 kg (19.5 - 19.9 lbs.)



Rotary Hammer HR4501C



Continuous rating	1,350W
Input	
Blows per minute	1,250 - 2,750 min ⁻¹
No load speed	130 - 280 min ⁻¹
Capacity	Concrete (w/ TCT bit): 45 mm (1-3/4") Masonry: 45 mm (1-3/4")
Impact energy	EPTA-Procedure 05/2009: 10.1 J
Dimensions (L x W x H)	458 x 121 x 288 mm (18 x 4-3/4 x 11-3/8")
Net weight	8.2 - 8.4 kg (18.1 - 18.5 lbs.)



Rotary Hammer HR4041C



Continuous rating	1,100W
Input	
Blows per minute	1,300 - 2,600 min ⁻¹
No load speed	230 - 460 min ⁻¹
Capacity	Concrete (w/ TCT bit): 40 mm (1-9/16") Masonry: 40 mm (1-9/16")
Dimensions (L x W x H)	428 x 107 x 247 mm (16-7/8 x 4-1/4 x 9-3/4")
Net weight	6.7 kg (14.8 lbs.)



Rotary Hammer HR4030C



Continuous rating	1,100W
Input	
Blows per minute	1,300 - 2,600 min ⁻¹
No load speed	230 - 460 min ⁻¹
Capacity	Concrete (w/ TCT bit): 40 mm (1-9/16") Masonry: 40 mm (1-9/16")
Dimensions (L x W x H)	413 x 107 x 247 mm (16-1/4 x 4-1/4 x 9-3/4")
Net weight	6.9 kg (15.2 lbs.)



Rotary Hammer HR4003C



Continuous rating	1,100W
Input	
Blows per minute	1,450 - 2,900 min ⁻¹
No load speed	250 - 500 min ⁻¹
Capacity	Concrete (w/ TCT bit): 40 mm (1-9/16") Masonry: 40 mm (1-9/16")
Impact energy	EPTA-Procedure 05/2009: 8.3 J
Dimensions (L x W x H)	479 x 106 x 263 mm (18-11/16 x 4-3/16 x 10-3/8")
Net weight	6.2 - 6.4 kg (13.7 - 14.1 lbs.)



Hammer drilling/Chiselling

Rotary Hammer HR4013C



Continuous rating	1,100W
Input	
Blows per minute	1,450 - 2,900 min ⁻¹
No load speed	250 - 500 min ⁻¹
Capacity	Concrete (w/ TCT bit): 40 mm (1-9/16") Masonry: 40 mm (1-9/16")
Impact energy	EPTA-Procedure 05/2009: 8 J
Dimensions (L x W x H)	479 x 112 x 263 mm (18-11/16 x 4-3/8 x 10-3/8")
Net weight	6.8 - 6.9 kg (14.9 - 15.3 lbs.)

AVT *SOFT*
NOLOAD



Rotary Hammer HR3530



Continuous rating	1,010W
Input	
Blows per minute	3,100 min ⁻¹
No load speed	760 min ⁻¹
Capacity	Concrete (w/ TCT bit): 35 mm (1-3/8") Masonry: 35 mm (1-3/8")
Dimensions (L x W x H)	374 x 100 x 243 mm (14-3/4 x 3-15/16 x 9-9/16")
Net weight	5.8 kg (12.8 lbs.)



Combination Hammer HR3540C



Continuous rating	850W
Input	
Blows per minute	1,650 - 3,300 min ⁻¹
No load speed	315 - 630 min ⁻¹
Capacity	Concrete (w/ TCT bit): 35 mm (1-3/8") Masonry: 35 mm (1-3/8") Steel: 13 mm (1/2") Wood: 32 mm (1-1/4") Wood (Self-feed bit): 32 mm (1-1/4")
Impact energy	EPTA-Procedure 05/2009: 5.6 J
Chuck capacity	1.5 - 13 mm (1/16 - 1/2")
Dimensions (L x W x H)	439 x 108 x 239 mm (17-1/4 x 4-1/4 x 9-3/8")
Net weight	5.2 - 5.3 kg (11.4 - 11.6 lbs.)



Combination Hammer HR3210C



Continuous rating	850W
Input	
Blows per minute	1,650 - 3,300 min ⁻¹
No load speed	315 - 630 min ⁻¹
Capacity	Concrete (w/ TCT bit): 32 mm (1-1/4") Masonry: 32 mm (1-1/4") Steel: 13 mm (1/2") Wood: 32 mm (1-1/4") Wood (Self-feed bit): 32 mm (1-1/4")
Impact energy	EPTA-Procedure 05/2009: 5 J
Chuck capacity	1.5 - 13 mm (1/16 - 1/2")
Dimensions (L x W x H)	398 x 114 x 239 mm (15-5/8 x 4-1/2 x 9-3/8")
Net weight	5.2 - 5.6 kg (11.4 - 12.4 lbs.)

AVT



Combination Hammer HR3012FC



Continuous rating	1,050W
Input	
Blows per minute	0 - 4,500 min ⁻¹
No load speed	0 - 840 min ⁻¹
Capacity	Concrete (w/ TCT bit): 30 mm (1-3/16") Masonry: 30 mm (1-3/16") Steel: 13 mm (1/2") Wood: 32 mm (1-1/4") Wood (Self-feed bit): 32 mm (1-1/4")
Impact energy	EPTA-Procedure 05/2009: 3.9 J
Chuck capacity	1.5 - 13 mm (1/16 - 1/2")
Dimensions (L x W x H)	386 x 98 x 242 mm (15-1/4 x 3-7/8 x 9-1/2")
Net weight	4.5 - 4.7 kg (9.9 - 10.4 lbs.)

AVT



Quick change drill chuck

Rotary Hammer HR4002



Continuous rating	1,050W
Input	
Blows per minute	2,500 min ⁻¹
No load speed	680 min ⁻¹
Capacity	Concrete (w/ TCT bit): 40 mm (1-9/16") Masonry: 40 mm (1-9/16")
Impact energy	EPTA-Procedure 05/2009: 6.1 J
Dimensions (L x W x H)	458 x 114 x 256 mm (18 x 4-1/2 x 10-1/8")
Net weight	6.6 - 6.8 kg (14.6 - 15 lbs.)



Combination Hammer HR3541FC



Continuous rating	850W
Input	
Blows per minute	1,650 - 3,300 min ⁻¹
No load speed	315 - 630 min ⁻¹
Capacity	Concrete (w/ TCT bit): 35 mm (1-3/8") Masonry: 35 mm (1-3/8") Steel: 13 mm (1/2") Wood: 32 mm (1-1/4") Wood (Self-feed bit): 32 mm (1-1/4")
Impact energy	EPTA-Procedure 05/2009: 5.7 J
Chuck capacity	1.5 - 13 mm (1/16 - 1/2")
Dimensions (L x W x H)	439 x 114 x 239 mm (17-1/4 x 4-1/2 x 9-3/8")
Net weight	5.6 - 5.7 kg (12.3 - 12.6 lbs.)

AVT



Combination Hammer HR3210FCT



Continuous rating	850W
Input	
Blows per minute	1,650 - 3,300 min ⁻¹
No load speed	315 - 630 min ⁻¹
Capacity	Concrete (w/ TCT bit): 32 mm (1-1/4") Masonry: 32 mm (1-1/4") Steel: 13 mm (1/2") Wood: 32 mm (1-1/4") Wood (Self-feed bit): 32 mm (1-1/4")
Impact energy	EPTA-Procedure 05/2009: 4.9 J
Chuck capacity	1.5 - 13 mm (1/16 - 1/2")
Dimensions (L x W x H)	424 x 114 x 239 mm (16-3/4 x 4-1/2 x 9-3/8")
Net weight	5.4 - 5.6 kg (11.9 - 12.3 lbs.)

AVT



Quick change drill chuck

Combination Hammer HR3200C



Continuous rating	850W
Input	
Blows per minute	1,650 - 3,300 min ⁻¹
No load speed	315 - 630 min ⁻¹
Capacity	Concrete (w/ TCT bit): 32 mm (1-1/4") Masonry: 32 mm (1-1/4") Steel: 13 mm (1/2") Wood: 32 mm (1-1/4") Wood (Self-feed bit): 32 mm (1-1/4")
Impact energy	EPTA-Procedure 05/2009: 5.1 J
Chuck capacity	1.5 - 13 mm (1/16 - 1/2")
Dimensions (L x W x H)	398 x 108 x 239 mm (15-5/8 x 4-1/4 x 9-3/8")
Net weight	4.8 - 5.2 kg (10.5 - 11.5 lbs.)

AVT



Combination Hammer HR3011FC



Continuous rating	1,050W
Input	
Blows per minute	0 - 4,500 min ⁻¹
No load speed	0 - 840 min ⁻¹
Capacity	Concrete (w/ TCT bit): 30 mm (1-3/16") Masonry: 30 mm (1-3/16") Steel: 13 mm (1/2") Wood: 32 mm (1-1/4") Wood (Self-feed bit): 32 mm (1-1/4")
Impact energy	EPTA-Procedure 05/2009: 3.9 J
Chuck capacity	1.5 - 13 mm (1/16 - 1/2")
Dimensions (L x W x H)	369 x 98 x 242 mm (14-1/2 x 3-7/8 x 9-1/2")
Net weight	4.4 - 4.8 kg (9.7 - 10.6 lbs.)

AVT



Hammer drilling/Chiselling

Combination Hammer HR3001C



Continuous rating Input	1,050W
Blows per minute	0 - 4,500 min ⁻¹
No load speed	0 - 840 min ⁻¹
Capacity	Concrete (w/ TCT bit): 30 mm (1-3/16") Masonry: 30 mm (1-3/16") Steel: 13 mm (1/2") Wood: 32 mm (1-1/4") Wood (Self-feed bit): 32 mm (1-1/4")
Impact energy	EPTA-Procedure 05/2009: 3.9 J
Chuck capacity	1.5 - 13 mm (1/16 - 1/2")
Dimensions (L x W x H)	369 x 98 x 226 mm (14-1/2 x 3-7/8 x 8-7/8")
Net weight	4.1 - 4.5 kg (9.0 - 9.9 lbs.)



Combination Hammer HR2811FT



Continuous rating Input	800W
Blows per minute	0 - 4,500 min ⁻¹
No load speed	0 - 1,100 min ⁻¹
Capacity	Concrete (w/ TCT bit): 28 mm (1-1/8") Masonry: 28 mm (1-1/4") Steel: 13 mm (1/2") Wood: 32 mm (1-1/4") Wood (Self-feed bit): 32 mm (1-1/4")
Impact energy	EPTA-Procedure 05/2009: 2.9 J
Chuck capacity	1.5 - 13 mm (1/16 - 1/2")
Dimensions (L x W x H)	345 x 89 x 225 mm (13-5/8 x 3-1/2 x 8-7/8")
Net weight	3.6 - 3.9 kg (8 - 8.6 lbs.)



Quick change drill chuck

Combination Hammer HR2811F



Continuous rating Input	800W
Blows per minute	0 - 4,500 min ⁻¹
No load speed	0 - 1,100 min ⁻¹
Capacity	Concrete (w/ TCT bit): 28 mm (1-1/8") Masonry: 28 mm (1-1/8") Steel: 13 mm (1/2") Wood: 32 mm (1-1/4") Wood (Self-feed bit): 32 mm (1-1/4")
Impact energy	EPTA-Procedure 05/2009: 2.8 J
Chuck capacity	1.5 - 13 mm (1/16 - 1/2")
Dimensions (L x W x H)	320 x 89 x 225 mm (12-5/8 x 3-1/2 x 8-7/8")
Net weight	3.5 - 3.9 kg (7.7 - 8.7 lbs.)



Combination Hammer HR2810T



Continuous rating Input	800W
Blows per minute	0 - 4,500 min ⁻¹
No load speed	0 - 1,100 min ⁻¹
Capacity	Concrete (w/ TCT bit): 28 mm (1-1/8") Masonry: 28 mm (1-1/8") Steel: 13 mm (1/2") Wood: 32 mm (1-1/4") Wood (Self-feed bit): 32 mm (1-1/4")
Impact energy	EPTA-Procedure 05/2009: 2.9 J
Chuck capacity	1.5 - 13 mm (1/16 - 1/2")
Dimensions (L x W x H)	339 x 89 x 225 mm (13-3/8 x 3-1/2 x 8-7/8")
Net weight	3.5 - 3.8 kg (7.8 - 8.4 lbs.)



Quick change drill chuck

Combination Hammer HR2810



Continuous rating Input	800W
Blows per minute	0 - 4,500 min ⁻¹
No load speed	0 - 1,100 min ⁻¹
Capacity	Concrete (w/ TCT bit): 28 mm (1-1/8") Masonry: 28 mm (1-1/8") Steel: 13 mm (1/2") Wood: 32 mm (1-1/4") Wood (Self-feed bit): 32 mm (1-1/4")
Impact energy	EPTA-Procedure 05/2009: 2.8 J
Chuck capacity	1.5 - 13 mm (1/16 - 1/2")
Dimensions (L x W x H)	314 x 89 x 225 mm (12-3/8 x 3-1/2 x 8-7/8")
Net weight	3.4 - 3.8 kg (7.5 - 8.5 lbs.)



Rotary Hammer HR2800



Continuous rating Input	800W
Blows per minute	0 - 4,500 min ⁻¹
No load speed	0 - 1,100 min ⁻¹
Capacity	Concrete (w/ TCT bit): 28 mm (1-1/8") Masonry: 28 mm (1-1/8") Steel: 13 mm (1/2") Wood: 32 mm (1-1/4") Wood (Self-feed bit): 32 mm (1-1/4")
Impact energy	EPTA-Procedure 05/2009: 2.8 J
Chuck capacity	1.5 - 13 mm (1/16 - 1/2")
Dimensions (L x W x H)	314 x 89 x 225 mm (12-3/8 x 3-1/2 x 8-7/8")
Net weight	3.4 - 3.8 kg (7.4 - 8.4 lbs.)



Combination Hammer HR2670FT

new



Continuous rating input	800 W
Impacts per minute	0 - 4,500 min ⁻¹
No load speed	0 - 1,500 min ⁻¹
Capacity	Concrete (w/ TCT bit): 26 mm (1") Steel: 13 mm (1/2") Wood: 32 mm (1-1/4")
Impact energy	3.0 J
Dimensions (L x W x H)	390 x 77 x 207 mm (15-3/8 x 3 x 8-1/8")
Net weight	3.1 - 3.3 kg (6.8 - 7.3 lbs.)



Quick change drill chuck

Combination Hammer HR2670

new



Continuous rating input	800 W
Impacts per minute	0 - 4,500 min ⁻¹
No load speed	0 - 1,500 min ⁻¹
Capacity	Concrete (w/ TCT bit): 26 mm (1") Steel: 13 mm (1/2") Wood: 32 mm (1-1/4")
Impact energy	3.0 J
Dimensions (L x W x H)	362 x 77 x 207 mm (14-1/4 x 3 x 8-1/8")
Net weight	2.9 - 3.4 kg (6.4 - 7.5 lbs.)



Combination Hammer HR2641



Continuous rating Input	800W
Blows per minute	0 - 4,500 min ⁻¹
No load speed	0 - 1,100 min ⁻¹
Capacity	Concrete: 26 mm (1") Concrete (w/ TCT bit): 26 mm (1") Masonry: 26 mm (1") Steel: 13 mm (1/2") Wood: 32 mm (1-1/4") Wood (Self-feed bit): 32 mm (1-1/4")
Impact energy	2.4 J
Chuck capacity	1.5 - 13 mm (1/16 - 1/2")
Dimensions (L x W x H)	422 x 76 x 156 mm (16-5/8 x 3 x 6-1/8")
Net weight	3.1 - 3.5 kg (6.8 - 7.8 lbs.)



AVT

Combination Hammer HR2631FT



Continuous rating Input	800W
Blows per minute	0 - 4,600 min ⁻¹
No load speed	0 - 1,200 min ⁻¹
Capacity	Concrete: 26 mm (1") Concrete (w/ TCT bit): 26 mm (1") Masonry: 26 mm (1") Steel: 13 mm (1/2") Wood: 32 mm (1-1/4") Wood (Self-feed bit): 32 mm (1-1/4")
Impact energy	2.4 J
Chuck capacity	1.5 - 13 mm (1/16 - 1/2")
Dimensions (L x W x H)	385 x 77 x 209 mm (15-1/8 x 3 x 8-1/4")
Net weight	3.1 - 3.6 kg (6.8 - 7.9 lbs.)



AVT

Quick change drill chuck

Hammer drilling/Chiselling

Combination Hammer HR2631F



Continuous rating Input	800W
Blows per minute	0 - 4,600 min ⁻¹
No load speed	0 - 1,200 min ⁻¹
Capacity	Concrete: 26 mm (1") Concrete (w/ TCT bit): 26 mm (1") Masonry: 26 mm (1") Steel: 13 mm (1/2") Wood: 32 mm (1-1/4") Wood (Self-feed bit): 32 mm (1-1/4")
Impact energy	2.4 J
Chuck capacity	1.5 - 13 mm (1/16 - 1/2")
Dimensions (L x W x H)	361 x 77 x 209 mm (14-1/4 x 3 x 8-1/4")
Net weight	2.9 - 3.4 kg (6.4 - 7.4 lbs.)

AVT



Rotary Hammer HR2601



Continuous rating Input	800W
Blows per minute	0 - 4,600 min ⁻¹
No load speed	0 - 1,200 min ⁻¹
Capacity	Concrete (w/ TCT bit): 26 mm (1") Masonry: 26 mm (1") Steel: 13 mm (1/2") Wood: 32 mm (1-1/4") Wood (Self-feed bit): 32 mm (1-1/4")
Impact energy	EPTA-Procedure 05/2009: 2.4 J
Chuck capacity	1.5 - 13 mm (1/16 - 1/2")
Dimensions (L x W x H)	361 x 77 x 209 mm (14-1/4 x 3 x 8-1/4")
Net weight	3.1 - 3.6 kg (6.9 - 7.8 lbs.)

AVT



Rotary Hammer HR2600



Continuous rating Input	800W
Blows per minute	0 - 4,600 min ⁻¹
No load speed	0 - 1,200 min ⁻¹
Capacity	Concrete (w/ TCT bit): 26 mm (1") Masonry: 26 mm (1") Steel: 13 mm (1/2") Wood: 32 mm (1-1/4") Wood (Self-feed bit): 32 mm (1-1/4")
Impact energy	EPTA-Procedure 05/2009: 2.4 J
Chuck capacity	1.5 - 13 mm (1/16 - 1/2")
Dimensions (L x W x H)	361 x 77 x 209 mm (14-1/4 x 3 x 8-1/4")
Net weight	3 - 3.4 kg (6.5 - 7.5 lbs.)



Combination Hammer with Self Dust Collection HR2653T



Quick change drill chuck

Continuous rating Input	800W
Blows per minute	0 - 4,600 min ⁻¹
No load speed	0 - 1,200 min ⁻¹
Capacity	Concrete: 26 mm (1") Steel: 13 mm (1/2") Wood: 32 mm (1-1/4") Wood (Self-feed bit): 32 mm (1-1/4")
Impact energy	EPTA-Procedure 05/2009: 2.2 J
Dimensions (L x W x H)	630 x 89 x 260 mm (24-3/4 x 3-1/2 x 10-1/4")
Net weight	3.2 - 4.5 kg (7.2 - 9.9 lbs.)

AVT



Combination Hammer with Self Dust Collection HR2653



Continuous rating Input	800W
Blows per minute	0 - 4,600 min ⁻¹
No load speed	0 - 1,200 min ⁻¹
Capacity	Concrete: 26 mm (1") Steel: 13 mm (1/2") Wood: 32 mm (1-1/4") Wood (Self-feed bit): 32 mm (1-1/4")
Impact energy	EPTA-Procedure 05/2009: 2.2 J
Dimensions (L x W x H)	604 x 89 x 260 mm (23-3/4 x 3-1/2 x 10-1/4")
Net weight	3.1 - 4.3 kg (6.9 - 9.6 lbs.)

AVT



Combination Hammer with Self Dust Collection HR2652



Continuous rating Input	800W
Blows per minute	0 - 4,600 min ⁻¹
No load speed	0 - 1,200 min ⁻¹
Capacity	Concrete: 26 mm (1") Steel: 13 mm (1/2") Wood: 32 mm (1-1/4") Wood (Self-feed bit): 32 mm (1-1/4")
Impact energy	EPTA-Procedure 05/2009: 2.2 J
Dimensions (L x W x H)	604 x 89 x 260 mm (23-3/4 x 3-1/2 x 10-1/4")
Net weight	3 - 4.3 kg (6.7 - 9.4 lbs.)



Combination Hammer with Self Dust Collection HR2663



Continuous rating Input	800W
Blows per minute	0 - 4,500 min ⁻¹
No load speed	0 - 1,100 min ⁻¹
Capacity	Concrete: 26 mm (1") Steel: 13 mm (1/2") Wood: 32 mm (1-1/4") Wood (Self-feed bit): 32 mm (1-1/4")
Impact energy	EPTA-Procedure 05/2009: 2.2 J
Dimensions (L x W x H)	666 x 89 x 260 mm (26-1/4 x 3-1/2 x 10-1/4")
Net weight	3.3 - 4.6 kg (7.3 - 10.0 lbs.)

AVT



Combination Hammer HR2475



Continuous rating Input	780W
Blows per minute	0 - 4,500 min ⁻¹
No load speed	0 - 1,100 min ⁻¹
Capacity	Concrete: 24 mm (15/16") Masonry: 24 mm (15/16") Steel: 13 mm (1/2") Wood: 32 mm (1-1/4") Wood (Self-feed bit): 32 mm (1-1/4")
Impact energy	EPTA-Procedure 05/2009: 2.3 J
Chuck capacity	1.5 - 13 mm (1/16 - 1/2")
Dimensions (L x W x H)	429 x 84 x 158 mm (16-7/8 x 3-5/16 x 6-1/4")
Net weight	3 - 3.4 kg (6.6 - 7.6 lbs.)



Combination Hammer HR2320T



Quick change drill chuck

Continuous rating Input	720W
Blows per minute	0 - 4,600 min ⁻¹
No load speed	0 - 1,200 min ⁻¹
Capacity	Concrete: 23 mm (7/8") Masonry: 23 mm (7/8") Steel: 13 mm (1/2") Wood: 32 mm (1-1/4") Wood (Self-feed bit): 32 mm (1-1/4")
Impact energy	EPTA-Procedure 05/2009: 2.3 J
Chuck capacity	1.5 - 13 mm (1/16 - 1/2")
Dimensions (L x W x H)	380 x 77 x 209 mm (15 x 3 x 8-1/4")
Net weight	2.9 - 3.2 kg (6.4 - 7 lbs.)



Hammer drilling/Chiselling

Rotary Hammer HR2300



Continuous rating Input	720W
Blows per minute	0 - 4,600 min ⁻¹
No load speed	0 - 1,200 min ⁻¹
Capacity	Concrete (w/ TCT bit): 23 mm (7/8") Masonry: 23 mm (7/8") Steel: 13 mm (1/2") Wood: 32 mm (1-1/4") Wood (Self-feed bit): 32 mm (1-1/4")
Impact energy	EPTA-Procedure 05/2009: 2.3 J
Chuck capacity	1.5 - 13 mm (1/16 - 1/2")
Dimensions (L x W x H)	356 x 77 x 209 mm (14 x 3 x 8-1/4")
Net weight	2.7 - 3.1 kg (5.9 - 6.9 lbs.)



Rotary Hammer HR2230



Continuous rating Input	710W
Blows per minute	0 - 4,050 min ⁻¹
No load speed	0 - 1,050 min ⁻¹
Capacity	Concrete (w/ TCT bit): 22 mm (7/8") Masonry: 22 mm (7/8") Steel: 13 mm (1/2") Wood: 32 mm (1-1/4") Wood (Self-feed bit): 32 mm (1-1/4")
Impact energy	EPTA-Procedure 05/2009: 2.2 J
Chuck capacity	1.5 - 13 mm (1/16 - 1/2")
Dimensions (L x W x H)	357 x 84 x 214 mm (14 x 3-5/16 x 8-3/8")
Net weight	2.6 - 3.1 kg (5.8 - 6.8 lbs.)



Rotary Hammer HR1841F



Continuous rating Input	470W
Blows per minute	0 - 4,800 min ⁻¹
No load speed	0 - 2,100 min ⁻¹
Capacity	Concrete: 18 mm (11/16") Masonry: 18 mm (11/16") Steel: 13 mm (1/2") Wood: 24 mm (15/16")
Impact energy	EPTA-Procedure 05/2009: 1.4 J
Chuck capacity	1.5 - 13 mm (1/16 - 1/2")
Dimensions (L x W x H)	285 x 75 x 208 mm (11-1/4 x 3 x 8-3/16")
Net weight	2 - 2.5 kg (4.5 - 5.4 lbs.)

AVT



Rotary Hammer HR1840



Continuous rating Input	470W
Blows per minute	0 - 4,800 min ⁻¹
No load speed	0 - 2,100 min ⁻¹
Capacity	Concrete: 18 mm (11/16") Masonry: 18 mm (11/16") Steel: 13 mm (1/2") Wood: 24 mm (15/16")
Chuck capacity	EPTA-Procedure 05/2009: 1.4 J
Dimensions (L x W x H)	285 x 75 x 208 mm (11-1/4 x 3 x 8-3/16")
Net weight	2 - 2.4 kg (4.3 - 5.3 lbs.)



Compatibility list between Model and Drill Bit

Adapted for SDS-MAX bits
 Adapted for SDS-PLUS bits

Compatible size range of TCT Drill Bit
 Recommended size range of Drill Bit
 Compatible size range of Core Bit

Hammer drilling / Chiselling

Capacity	Bit	Model No.	Battery	[cm]																	
				0	5	10	15	20	25	30	40	50	60	70	80	90	100	110	120	130	140
14 mm		HR140D	12V max	3.2-14		3.2-10		Diamond Core Bit/Core Bit not recommended													
16 mm		HR166D	12V max	3.2-16		3.2-10		Diamond Core Bit/Core Bit not recommended													
16 mm		DHR165	18V	3.2-16		3.2-10		35	Diamond Core Bit (Dry Type): 32 mm												
17 mm		DHR171	18V	3.2-17		3.2-10		Diamond Core Bit/Core Bit not recommended													
18 mm		DHR182	18V	3.2-18		3.2-10		35	Diamond Core Bit (Dry Type): 32 mm												
18 mm		DHR183	18V	3.2-18		3.2-10		Diamond Core Bit/Core Bit not recommended													
20 mm		DHR202	18V	3.2-20		4-12		35-54		Diamond Core Bit (Dry Type): 32 mm											
20 mm		HR010G	40V max	3.2-20		3.2-12		35	Diamond Core Bit (Dry Type): 32 mm												
24 mm		DHR241	18V	3.2-20		4-12		35-54		Diamond Core Bit (Dry Type): 32 mm											
24 mm		DHR243 / DHR242	18V	3.2-24		4-16		35-54		Diamond Core Bit (Dry Type): 32~65 mm											
26 mm		DHR264 / DHR263	18V x2	3.2-26		4-18		35-54		Diamond Core Bit (Dry Type): 32~65 mm											
28 mm		DHR283 / DHR282 / DHR281 / DHR280	18V x2	3.2-28		6-20		35-54		Diamond Core Bit (Dry Type): 32~65 mm											
28 mm		HR002G / HR001G / HR004G / HR003G	40V max	3.2-28		6-20		35-54		Diamond Core Bit (Dry Type): 32~65 mm											
28 mm		HR007G	40V max	3.2-28		6-20		35-54		Diamond Core Bit (Dry Type): 32~65 mm											
30 mm		HR009G / HR008G	40V max	6-30		8-22		35-80		Diamond Core Bit (Dry Type): 32~80 mm											
40 mm		DHR400	18V x2	10-40		16-35		20-105													
40 mm		HR005G	40V max	10-40		16-35		20-105													
52 mm		HR006G	40V max x2	19-52		25-45		20-160													

Compatibility list between Model and Drill Bit







































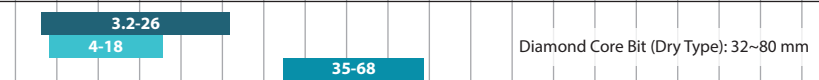







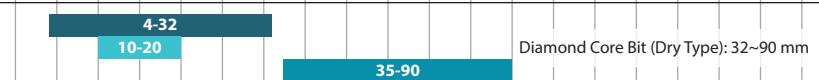





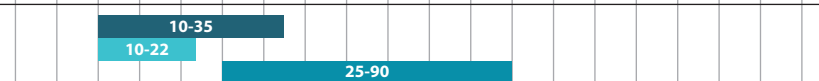







 Adapted for SDS-MAX bits

 Adapted for SDS-PLUS bits

 Compatible size range of TCT Drill Bit

 Recommended size range of Drill Bit

 Compatible size range of Core Bit

Capacity	Bit	Model No.	Powered	[cm]																
				0	5	10	15	20	25	30	40	50	60	70	80	90	100	110	120	130
18 mm		HR1841F / HR1840 	AC																	
22 mm		HR2230 	AC																	
23 mm		HR2320T 	AC																	
23 mm		HR2300 	AC																	
24 mm		HR2475 	AC																	
26 mm		HR2641 	AC																	
26 mm		HR2631FT / HR2631F 	AC																	
26 mm		HR2600 / HR2601 	AC																	
26 mm		HR2653T / HR2653 / HR2652 / HR2663 	AC																	
26 mm		HR2670FT / HR2670 	AC																	
28 mm		HR2811FT / HR2811F / HR2810T / HR2810 / HR2800 	AC																	
30 mm		HR3012FC / HR3011FC / HR3001C 	AC																	
32 mm		HR3210FCT / HR3210C / HR3200C 	AC																	
35 mm		HR3530 	AC																	
35 mm		HR3541FC / HR3540C 	AC																	
40 mm		HR4041C 	AC																	
40 mm		HR4030C 	AC																	
40 mm		HR4013C / HR4003C 	AC																	
40 mm		HR4002 	AC																	
45 mm		HR4511C / HR4510C / HR4501C 	AC																	
52 mm		HR5212C / HR5202C 	AC																	

Comparison List

Model No.	Powered	Capacity / Concrete (mm)	Impact energy (EPTA-Procedure 05/2009)	Type	Net weight (kg)	AVT	Soft No load	Built-in Job Light	Quick change
-----------	---------	--------------------------	--	------	-----------------	-----	--------------	--------------------	--------------

Cordless Rotary Hammer / Cordless Combination Hammer

SDS-MAX Shank

HR006G	40Vmax x2	52	21.4	Rotary	12.9 - 14.3 kg (28.4 - 31.5 lbs.)	●	●	●	-
HR005G	40Vmax	40	8	Rotary	7.4 - 8.2 kg (16.3 - 18.1 lbs.)	●	●	●	-
DHR400	18V x2	40	8	Rotary	7.3 - 8.1 kg (16.1 - 17.9 lbs.)	●	●	●	-

SDS-PLUS Shank

HR009G	40Vmax	30	3.9	Combination	5.3 - 6.7 kg (11.7 - 14.8 lbs.)	●	-	●	●
HR008G	40Vmax	30	3.9	Combination	5.2 - 6.8 kg (11.5 - 15.0 lbs.)	●	-	●	-
HR002G	40Vmax	28	2.9	Combination	4.1 - 4.6 kg (9.0 - 10.1 lbs.)	●	●	●	●
HR001G	40Vmax	28	2.8	Combination	3.9 - 4.6 kg (8.6 - 10.1 lbs.)	●	●	●	-
HR004G	40Vmax	28	2.9	Combination	4.0 - 4.5 kg (8.8 - 9.9 lbs.)	●	-	●	●
HR003G	40Vmax	28	2.8	Combination	3.9 - 4.6 kg (8.6 - 10.1 lbs.)	●	-	●	-
HR007G	40Vmax	28	3	Combination	3.8 - 4.8 kg (8.4 - 10.6 lbs.)	●	-	●	-
HR010G	40Vmax	20	2.1	Combination	2.8 - 4.5 kg (6.2 - 9.9 lbs.)	●	-	●	-
DHR283	18V x2	28	2.9	Combination	4.0 - 4.9 kg (8.8 - 10.8 lbs.)	●	●	●	●
DHR282	18V x2	28	2.8	Combination	3.9 - 5.0 kg (8.6 - 11.0 lbs.)	●	●	●	-
DHR281	18V x2	28	2.9	Combination	4.0 - 4.9 kg (8.8 - 10.8 lbs.)	●	●	●	●
DHR280	18V x2	28	2.8	Combination	3.8 - 4.9 kg (8.4 - 10.8 lbs.)	●	●	●	-
DHR264	18V x2	26	2.5	Combination	4.2 - 5.1 kg (9.2 - 11.2 lbs.)	-	-	●	●
DHR263	18V x2	26	2.5	Combination	4.1 - 5.1 kg (9 - 11.3 lbs.)	-	-	●	-
DHR243	18V	24	2	Combination	3.2 - 3.7 kg (6.9 - 8.3 lbs.)	-	-	-	●
DHR242	18V	24	2	Combination	3.1 - 3.8 kg (6.7 - 8.4 lbs.)	-	-	-	-
DHR241	18V	20	1.9	Combination	3.2 - 4 kg (7.1 - 8.8 lbs.)	-	-	-	-
DHR202	18V	20	2	Combination	3.2 - 4 kg (7.1 - 8.8 lbs.)	-	-	●	-
DHR183	18V	18	1.7	Rotary	2.1 - 2.9 kg (4.6 - 6.4 lbs.)	●	-	●	-
DHR182	18V	18	1.7	Combination	2.4 - 3.2 kg (5.3 - 7.0 lbs.)	●	-	●	-
DHR171	18V	17	1.2	Rotary	2.1 - 2.8 kg (4.6 - 6.2 lbs.)	-	-	●	-
DHR165	18V	16	1.3	Rotary	2.3 - 3 kg (5 - 6.6 lbs.)	-	-	●	-
HR166D	12Vmax	16	1.1	Rotary	1.8 - 2.4 kg (4.1 - 5.4 lbs.)	-	-	●	-
HR140D	12Vmax	14	1	Rotary	1.9 - 2.6 kg (4.3 - 5.6 lbs.)	-	-	●	-

Comparison List

Model No.	Capacity (mm)	Continuous rating Input (W)	Impact energy (EPTA-Procedure 05/2009)	Type	Net weight (kg)	AVT	Soft No load	Built-in Job Light	Quick change
Rotary Hammer / Combination Hammer									
SDS-MAX Shank									
HR5212C	52	1,510	20	Rotary	11.9 - 12.0 kg (26.2 - 26.5 lbs)	●	●	-	-
HR5202C	52	1,510	19.1	Rotary	10.9 - 11.1 kg (24.1 - 24.4 lbs)	-	-	-	-
HR4511C	45	1,350	9.4	Rotary	9.0 - 9.1 kg (19.8 - 20.1 lbs)	●	-	-	-
HR4510C	45	1,350	9.4	Rotary	8.9 - 9.0 kg (19.5 - 19.9 lbs)	●	-	-	-
HR4501C	45	1,350	10.1	Rotary	8.2 - 8.4 kg (18.1 - 18.5 lbs)	-	-	-	-
HR4003C	40	1,100	8.3	Rotary	6.2 - 6.4 kg (13.7 - 14.1 lbs)	-	-	-	-
HR4013C	40	1,100	8	Rotary	6.8 - 6.9 kg (14.9 - 15.3 lbs)	●	●	-	-
HR4002	40	1,050	6.1	Rotary	6.6 - 6.8 kg (14.6 - 15.0 lbs)	-	-	-	-
HR3541FC	35	850	5.7	Combination	5.6 - 5.7 kg (12.3 - 12.6 lbs)	●	-	●	-
HR3540C	35	850	5.6	Combination	5.2 - 5.3 kg (11.4 - 11.6 lbs)	-	-	-	-
SDS-PLUS Shank									
HR3210FCT	32	850	4.9	Combination	5.4 - 5.6 kg (11.9 - 12.3 lbs)	●	-	●	●
HR3210C	32	850	5	Combination	5.2 - 5.6 kg (11.4 - 12.4 lbs)	●	-	-	-
HR3200C	32	850	5.1	Combination	4.8 - 5.2 kg (10.5 - 11.5 lbs)	-	-	-	-
HR3012FC	30	1,050	3.9	Combination	4.5 - 4.7 kg (9.9 - 10.4 lbs.)	●	-	●	●
HR3011FC	30	1,050	3.9	Combination	4.4 - 4.8 kg (9.7 - 10.6 lbs.)	●	-	●	-
HR3001C	30	1,050	3.9	Combination	4.1 - 4.5 kg (9.0 - 9.9 lbs.)	-	-	-	-
HR2811FT	28	800	2.9	Combination	3.6 - 3.9 kg (8.0 - 8.6 lbs)	-	-	●	●
HR2811F	28	800	2.8	Combination	3.5 - 3.9 kg (7.7 - 8.7 lbs)	-	-	●	-
HR2810T	28	800	2.9	Combination	3.5 - 3.8 kg (7.8 - 8.4 lbs)	-	-	-	●
HR2810	28	800	2.8	Combination	3.4 - 3.8 kg (7.5 - 8.5 lbs)	-	-	-	-
HR2800	28	800	2.8	Rotary	3.4 - 3.8 kg (7.4 - 8.4 lbs)	-	-	-	-
HR2670FT	26	800	3.0	Combination	3.1 - 3.3 kg (6.8 - 7.3 lbs.)	-	-	●	●
HR2670	26	800	3.0	Combination	2.9 - 3.4 kg (6.4 - 7.5 lbs.)	-	-	-	-
HR2641(D handle)	26	800	2.4	Combination	3.1 - 3.5 kg (6.8 - 7.8 lbs)	●	-	-	-
HR2631FT	26	800	2.4	Combination	3.1 - 3.6 kg (6.8 - 7.9 lbs)	●	-	●	●
HR2631F	26	800	2.4	Combination	2.9 - 3.4 kg (6.4 - 7.4 lbs)	●	-	●	-
HR2601	26	800	2.4	Rotary	3.1 - 3.6 kg (6.9 - 7.8 lbs)	●	-	-	-
HR2600	26	800	2.4	Rotary	3.0 - 3.4 kg (6.5 - 7.5 lbs)	-	-	-	-
HR2653T	26	800	2.2	Combination	3.2 - 4.5 kg (7.2 - 9.9 lbs.)	●	-	-	●
HR2653	26	800	2.2	Combination	3.1 - 4.3 kg (6.9 - 9.6 lbs.)	●	-	-	-
HR2652	26	800	2.2	Combination	3.0 - 4.3 kg (6.7 - 9.4 lbs.)	-	-	-	-
HR2663(D handle)	26	800	2.2	Combination	3.3 - 4.6 kg (7.3 - 10.0 lbs.)	●	-	-	-
HR2475(D handle)	24	780	2.3	Combination	3.0 - 3.4 kg (6.6 - 7.6 lbs)	-	-	-	-
HR2320T	23	720	2.3	Combination	2.9 - 3.2 kg (6.4 - 7.0 lbs)	-	-	-	●
HR2300	23	720	2.3	Rotary	2.7 - 3.1 kg (5.9 - 6.9 lbs)	-	-	-	-
HR2230	22	710	2.2	Rotary	2.6 - 3.1 kg (5.8 - 6.8 lbs)	-	-	-	-
HR1841F / HR1840	18	470	1.4	Rotary	2.0 - 2.5 kg (4.5 - 5.4 lbs) / 2.0 - 2.4 kg (4.5 - 5.3 lbs)	● / -	-	● / -	-
17mm Hex Shank									
HR4030C	40	1,100	-	Rotary	6.9 kg (15.2 lbs)	-	-	-	-
19mm Hex Shank									
HR3530	35	1,010	-	Rotary	5.8 kg (12.8 lbs)	-	-	-	-
Splines Shank									
HR4041C	40	1,100	-	Rotary	6.7 kg (14.8 lbs)	-	-	-	-

Hammer drilling/Chiselling

Cordless Demolition Hammer HM002G

40V max x2



Blows per minute	950 - 1,900 min ⁻¹
Impact energy	EPTA-Procedure 05/2009: 20.9 J
Shank diameter	18 mm (11/16")
Dimensions (L x W x H)	w/ BL4050F: 574 x 156 x 344 mm (22-5/8 x 6-1/8 x 13-1/2")
Net weight	12.0 - 13.3 kg (26.5 - 29.3 lbs.)

XGT BL MOTOR AVT AWS SOFT NOLOAD XPT



Cordless Demolition Hammer HM001G

40V max



Blows per minute	0 - 2,650 min ⁻¹
Impact energy	EPTA-Procedure 05/2009: 9.4 J
Shank diameter	18 mm (11/16")
Dimensions (L x W x H)	w/ BL4050F: 516 x 113 x 280 mm (20-1/4 x 4-7/16 x 11")
Net weight	6.3 - 7.1 kg (13.9 - 15.7 lbs.)

XGT BL MOTOR AVT AWS SOFT NOLOAD XPT



Demolition Hammer HM1306



Continuous rating Input	1,510W
Blows per minute	1,450 min ⁻¹
Impact energy	EPTA-Procedure 05/2009: 21.7 J
Dimensions (L x W x H)	652 x 121 x 231 mm (25-3/4 x 4-3/4 x 9-1/8")
Net weight	15.1 kg (33.3 lbs.)



Demolition Hammer HM1205C



Continuous rating Input	1,510W
Blows per minute	950 - 1,900 min ⁻¹
Impact energy	EPTA-Procedure 05/2009: 19.1 J
Dimensions (L x W x H)	576 x 128 x 265 mm (22-3/4 x 5 x 10-3/8")
Net weight	9.7 kg (21.5 lbs.)



Demolition Hammer HM1214C



Continuous rating Input	1,510W
Blows per minute	950 - 1,900 min ⁻¹
Impact energy	EPTA-Procedure 05/2009: 19.9 J
Dimensions (L x W x H)	700 x 129 x 265 mm (27-1/2 x 5-1/8 x 10-3/8")
Net weight	12.3 kg (27.1 lbs.)

AVT SOFT NOLOAD



Demolition Hammer HM1203C



Continuous rating Input	1,510W
Blows per minute	950 - 1,900 min ⁻¹
Impact energy	EPTA-Procedure 05/2009: 19.1 J
Dimensions (L x W x H)	576 x 128 x 265 mm (22-3/4 x 5 x 10-3/8")
Net weight	9.7 kg (21.5 lbs.)



Demolition Hammer HM1213C



Continuous rating Input	1,510W
Blows per minute	950 - 1,900 min ⁻¹
Impact energy	EPTA-Procedure 05/2009: 18.6 J
Dimensions (L x W x H)	576 x 149 x 265 mm (22-3/4 x 5-7/8 x 10-3/8")
Net weight	10.8 kg (23.7 lbs.)

AVT SOFT NOLOAD



Demolition Hammer HM1201



Continuous rating Input	1,130W
Blows per minute	2,000 min ⁻¹
Impact energy	EPTA-Procedure 05/2009: 12.9 J
Overall length	480 mm (18-7/8")
Net weight	9.1 kg (20.1 lbs.)



Demolition Hammer HM1101C



Continuous rating Input	1,300W
Blows per minute	1,100 - 2,650 min ⁻¹
Impact energy	EPTA-Procedure 05/2009: 11.5 J
Dimensions (L x W x H)	528 x 115 x 247 mm (20-3/4 x 4-1/2 x 9-3/4")
Net weight	7.2 - 7.3 kg (15.8 - 16.1 lbs.)



Demolition Hammer HM1111C



Continuous rating Input	1,300W
Blows per minute	1,100 - 2,650 min ⁻¹
Impact energy	EPTA-Procedure 05/2009: 11.2 J
Dimensions (L x W x H)	528 x 126 x 247 mm (20-3/4 x 5 x 9-3/4")
Net weight	7.8 - 8 kg (17.3 - 17.6 lbs.)

AVT SOFT NOLOAD



Hammer drilling/Chiselling

Hammer drilling/Chiselling

Demolition Hammer HM0830

Continuous rating Input	1,010W
Blows per minute	2,700 min ⁻¹
Impact energy	Our experimental conditions: 8.3 J
Dimensions (L x W x H)	390 x 98 x 209 mm (15-3/8 x 3-7/8 x 8-1/4")
Net weight	4.9 kg (10.7 lbs.)



Demolition Hammer HM0870C

Continuous rating Input	1,100W
Blows per minute	1,100 - 2,650 min ⁻¹
Impact energy	EPTA-Procedure 05/2009: 7.6 J
Dimensions (L x W x H)	449 x 109 x 230 mm (17-3/4 x 4-1/4 x 9")
Net weight	5.1 - 5.3 kg (11.1 - 11.6 lbs.)



Demolition Hammer HM0810T

Continuous rating Input	900W
Blows per minute	2,900 min ⁻¹
Impact energy	EPTA-Procedure 05/2009: 7.2 J
Overall length	428 mm (16-7/8")
Net weight	6.3 kg (13.9 lbs.)



Cordless Breaker HM004G

40V max x2

Blows per minute	870 min ⁻¹
Impact energy	72.8 J (53.7 ft.lbs.)
Shank type	Hex 28.6 (1-1/8)
Dimensions (L x W x H)	882 x 227 x 540 mm (34-3/4 x 8-15/16 x 21-1/4")
Net weight	29.7 - 32.1 kg (65.5 - 70.8 lbs.)



Electric Breaker HM1802

Continuous rating Input	2,000W
Blows per minute	870 min ⁻¹
Impact energy	EPTA-Procedure 05/2009: 71.4 J
Dimensions (L x W x H)	843 x 210 x 608 mm (33-1/4 x 8-1/4 x 24")
Net weight	29.4 kg (64.8 lbs.)



Demolition Hammer HM0871C

Continuous rating Input	1,100W
Blows per minute	1,100 - 2,650 min ⁻¹
Impact energy	EPTA-Procedure 05/2009: 8.1 J
Dimensions (L x W x H)	466 x 116 x 230 mm (18-3/8 x 4-9/16 x 9")
Net weight	5.6 - 5.8 kg (12.4 - 12.8 lbs.)



AVT SOFT NO LOAD



Demolition Hammer HM0810

Continuous rating Input	900W
Blows per minute	2,900 min ⁻¹
Impact energy	Our experimental conditions: 7.6 J
Overall length	410 mm (16-1/8")
Net weight	6.7 kg (14.7 lbs.)



Demolition Hammer HM0810B

Continuous rating Input	420W
Blows per minute	2,900 min ⁻¹
Impact energy	EPTA-Procedure 05/2009: 5.3 J
Overall length	423 mm (16-5/8")
Net weight	6.6 kg (14.5 lbs.)



Electric Breaker HM1812

Continuous rating Input	2,000W
Blows per minute	870 min ⁻¹
Impact energy	EPTA-Procedure 05/2009: 72.8 J
Shank diameter	28.6 mm (1-1/8")
Dimensions (L x W x H)	843 x 210 x 608 mm (33-1/4 x 8-1/4 x 24")
Net weight	31.3 kg (69 lbs.)



AVT SOFT NO LOAD



Electric Breaker HM1511

Continuous rating Input	1,850W
Blows per minute	1,300 min ⁻¹
Impact energy	EPTA-Procedure 05/2009: 48.9 J
Dimensions (L x W x H)	781 x 130 x 266 mm (30-3/4 x 5-1/8 x 10-1/2")
Net weight	19.2 kg (42.3 lbs.)



AVT SOFT NO LOAD



Hammer drilling/Chiselling

Electric Breaker HM1501

Continuous rating	1,850W
Input	
Blows per minute	1,300 min ⁻¹
Impact energy	EPTA-Procedure 05/2009: 48.1 J
Dimensions (L x W x H)	781 x 130 x 266 mm (30-3/4 x 5-1/8 x 10-1/2")
Net weight	18.4 kg (40.6 lbs.)



Electric Breaker HM1502

Continuous rating	1,850W
Input	
Blows per minute	1,300 min ⁻¹
Impact energy	EPTA-Procedure 05/2009: 49.1 J
Dimensions (L x W x H)	809 x 130 x 266 mm (31-3/4 x 5-1/8 x 10-1/2")
Net weight	19.7 kg (43.4 lbs.)



Electric Breaker HM1307C

Continuous rating	1,510W
Input	
Blows per minute	730 - 1,450 min ⁻¹
Impact energy	EPTA-Procedure 05/2009: 25.5 J
Dimensions (L x W x H)	715 x 129 x 266 mm (28-1/8 x 5-1/8 x 10-1/2")
Net weight	15.3 kg (33.8 lbs.)



Electric Breaker HM1307CB

Continuous rating	1,510W
Input	
Blows per minute	730 - 1,450 min ⁻¹
Impact energy	EPTA-Procedure 05/2009: 23.6 J
Dimensions (L x W x H)	824 x 129 x 266 mm (32-1/2 x 5-1/8 x 10-1/2")
Net weight	17.3 kg (38.2 lbs.)



Power Scraper HK0500

Continuous rating	550W
Input	
Blows per minute	2,000 - 3,500 min ⁻¹
Impact energy	EPTA-Procedure 05/2009: 1.8 J
Overall length	468 mm (18-7/16")
Net weight	5.0 kg (11 lbs.)



Electric Breaker HM1512

Continuous rating	1,850W
Input	
Blows per minute	1,300 min ⁻¹
Impact energy	EPTA-Procedure 05/2009: 48.5 J
Dimensions (L x W x H)	809 x 130 x 266 mm (31-3/4 x 5-1/8 x 10-1/2")
Net weight	20.4 kg (45.0 lbs.)



AVT *SOFT*
NO LOAD



Electric Breaker HM1317C

Continuous rating	1,510W
Input	
Blows per minute	730 - 1,450 min ⁻¹
Impact energy	EPTA-Procedure 05/2009: 25 J
Dimensions (L x W x H)	715 x 129 x 266 mm (28-1/8 x 5-1/8 x 10-1/2")
Net weight	17 kg (37.5 lbs.)



AVT *SOFT*
NO LOAD



Electric Breaker HM1317CB

Continuous rating	1,510W
Input	
Blows per minute	730 - 1,450 min ⁻¹
Impact energy	EPTA-Procedure 05/2009: 26.5 J
Dimensions (L x W x H)	824 x 129 x 266 mm (32-1/2 x 5-1/8 x 10-1/2")
Net weight	19 kg (41.9 lbs.)



AVT *SOFT*
NO LOAD



Cordless Power Scraper DHK180

18V

Blows per minute	0 - 3,200 min ⁻¹
Impact energy	EPTA-Procedure 05/2009: 3.1 J
Continuous use	w/ BL1860B: 21 min.
Dimensions (L x W x H)	w/ BL1830B / BL1840B / BL1850B / BL1860B: 368 x 99 x 211 mm (14-1/2 x 3-7/8 x 8-5/16")
Net weight	3.3 - 3.6 kg (7.3 - 7.9 lbs.)



LXT **BL** **AVT** **XPT**
MOTOR



Power Scraper HK1820

Continuous rating	550W
Input	
Blows per minute	0 - 3,200 min ⁻¹
Impact energy	EPTA-Procedure 05/2009: 3.1 J
Dimensions (L x W x H)	351 x 102 x 203 mm (13-3/4 x 4 x 8")
Net weight	3.4 kg (7.5 lbs.)



Power Scraper HK1810



Continuous rating Input	505W
Blows per minute	0 - 3,200 min ⁻¹
Impact energy	EPTA-Procedure 05/2009: 1.8 J
Overall length	315 mm (12-3/8")
Net weight	3.2 kg (7.1 lbs.)



2-Speed Hammer Drill HP2071F



Continuous rating Input	1,010W
Impacts per minute	High: 0 - 58,000 min ⁻¹ Low: 0 - 24,000 min ⁻¹
No load speed	High: 0 - 2,900 min ⁻¹ Low: 0 - 1,200 min ⁻¹
Capacity	Concrete: 20 mm (3/4") Steel Hi: 8 mm (5/16") Steel Lo: 16 mm (5/8") Wood Hi: 25 mm (1") Wood Lo: 40 mm (1-9/16") Wood (Self-feed bit): 120 mm (4-3/4")
Chuck capacity	2.0 - 13 mm (1/16 - 1/2")
Overall length	362 mm (14-1/4")
Net weight	2.6 kg (5.7 lbs.)



2-Speed Hammer Drill HP2071



Continuous rating Input	1,010W
Impacts per minute	High: 0 - 58,000 min ⁻¹ Low: 0 - 24,000 min ⁻¹
No load speed	High: 0 - 2,900 min ⁻¹ Low: 0 - 1,200 min ⁻¹
Capacity	Concrete: 20 mm (3/4") Steel Hi: 8 mm (5/16") Steel Lo: 16 mm (5/8") Wood Hi: 25 mm (1") Wood Lo: 40 mm (1-9/16") Wood (Self-feed bit): 120 mm (4-3/4")
Chuck capacity	2.0 - 13 mm (1/16 - 1/2")
Overall length	362 mm (14-1/4")
Net weight	2.6 kg (5.7 lbs.)



2-Speed Hammer Drill HP2070F



Continuous rating Input	1,010W
Impacts per minute	High: 0 - 58,000 min ⁻¹ Low: 0 - 24,000 min ⁻¹
No load speed	High: 0 - 2,900 min ⁻¹ Low: 0 - 1,200 min ⁻¹
Capacity	Concrete: 20 mm (3/4") Steel Hi: 8 mm (5/16") Steel Lo: 16 mm (5/8") Wood Hi: 25 mm (1") Wood Lo: 40 mm (1-9/16") Wood (Self-feed bit): 120 mm (4-3/4")
Chuck capacity	2.0 - 13 mm (1/16 - 1/2")
Overall length	364 mm (14-3/8")
Net weight	2.6 kg (5.7 lbs.)



2-Speed Hammer Drill HP2070



Continuous rating Input	1,010W
Impacts per minute	High: 0 - 58,000 min ⁻¹ Low: 0 - 24,000 min ⁻¹
No load speed	High: 0 - 2,900 min ⁻¹ Low: 0 - 1,200 min ⁻¹
Capacity	Concrete: 20 mm (3/4") Steel Hi: 8 mm (5/16") Steel Lo: 16 mm (5/8") Wood Hi: 25 mm (1") Wood Lo: 40 mm (1-9/16") Wood (Self-feed bit): 120 mm (4-3/4")
Chuck capacity	2.0 - 13 mm (1/16 - 1/2")
Overall length	364 mm (14-3/8")
Net weight	2.6 kg (5.7 lbs.)



2-Speed Hammer Drill HP2051F



Continuous rating Input	720W
Impacts per minute	High: 0 - 58,000 min ⁻¹ Low: 0 - 24,000 min ⁻¹
No load speed	High: 0 - 2,900 min ⁻¹ Low: 0 - 1,200 min ⁻¹
Capacity	Concrete: 20 mm (3/4") Steel Hi: 8 mm (5/16") Steel Lo: 13 mm (1/2") Wood Hi: 25 mm (1") Wood Lo: 40 mm (1-9/16") Wood (Self-feed bit): 90 mm (3-1/2")
Chuck capacity	1.5 - 13 mm (1/16 - 1/2")
Overall length	360 mm (14-1/8")
Net weight	2.5 kg (5.6 lbs.)



2-Speed Hammer Drill HP2051



Continuous rating Input	720W
Impacts per minute	High: 0 - 58,000 min ⁻¹ Low: 0 - 24,000 min ⁻¹
No load speed	High: 0 - 2,900 min ⁻¹ Low: 0 - 1,200 min ⁻¹
Capacity	Concrete: 20 mm (3/4") Steel Hi: 8 mm (5/16") Steel Lo: 13 mm (1/2") Wood Hi: 25 mm (1") Wood Lo: 40 mm (1-9/16") Wood (Self-feed bit): 90 mm (3-1/2")
Chuck capacity	1.5 - 13 mm (1/16 - 1/2")
Overall length	360 mm (14-1/8")
Net weight	2.5 kg (5.6 lbs.)



2-Speed Hammer Drill HP2050F



Continuous rating Input	720W
Impacts per minute	High: 0 - 58,000 min ⁻¹ Low: 0 - 24,000 min ⁻¹
No load speed	High: 0 - 2,900 min ⁻¹ Low: 0 - 1,200 min ⁻¹
Capacity	Concrete: 20 mm (3/4") Steel Hi: 8 mm (5/16") Steel Lo: 13 mm (1/2") Wood Hi: 25 mm (1") Wood Lo: 40 mm (1-9/16") Wood (Self-feed bit): 90 mm (3-1/2")
Chuck capacity	1.5 - 13 mm (1/16 - 1/2")
Overall length	362 mm (14-1/4")
Net weight	2.5 kg (5.6 lbs.)



2-Speed Hammer Drill HP2050



Continuous rating Input	720W
Impacts per minute	High: 0 - 58,000 min ⁻¹ Low: 0 - 24,000 min ⁻¹
No load speed	High: 0 - 2,900 min ⁻¹ Low: 0 - 1,200 min ⁻¹
Capacity	Concrete: 20 mm (3/4") Steel Hi: 8 mm (5/16") Steel Lo: 13 mm (1/2") Wood Hi: 25 mm (1") Wood Lo: 40 mm (1-9/16") Wood (Self-feed bit): 90 mm (3-1/2")
Chuck capacity	1.5 - 13 mm (1/16 - 1/2")
Overall length	362 mm (14-1/4")
Net weight	2.5 kg (5.6 lbs.)



Hammer Drill HP1631



Continuous rating Input	710W
Blows per minute	0 - 48,000 min ⁻¹
No load speed	0 - 3,200 min ⁻¹
Capacity	Concrete: 16 mm (5/8") Masonry: 16 mm (5/8") Steel: 13 mm (1/2") Wood: 30 mm (1-3/16") Wood (Self-feed bit): 60 mm (2-3/8")
Chuck capacity	1.5 - 13 mm (1/16 - 1/2")
Dimensions (L x W x H)	296 x 75 x 204 mm (11-5/8 x 2-15/16 x 8")
Net weight	2 kg (4.4 lbs.)



Hammer drilling/Chiselling

Hammer Drill HP1630



Continuous rating Input	710W
Blows per minute	0 - 48,000 min ⁻¹
No load speed	0 - 3,200 min ⁻¹
Capacity	Concrete: 16 mm (5/8") Masonry: 16 mm (5/8") Steel: 13 mm (1/2") Wood: 30 mm (1-3/16") Wood (Self-feed bit): 60 mm (2-3/8")
Chuck capacity	1.5 - 13 mm (1/16 - 1/2")
Dimensions (L x W x H)	296 x 75 x 204 mm (11-5/8 x 2-15/16 x 8")
Net weight	2.1 kg (4.6 lbs.)



Hammer Drill HP1641



Continuous rating Input	680W
Blows per minute	0 - 44,800 min ⁻¹
No load speed	0 - 2,800 min ⁻¹
Capacity	Concrete: 16 mm (5/8") Masonry: 16 mm (5/8") Steel: 13 mm (1/2") Wood: 30 mm (1-3/16")
Chuck capacity	1.5 - 13 mm (1/16 - 1/2")
Dimensions (L x W x H)	303 x 72 x 222 mm (11-7/8 x 2-13/16 x 8-3/4")
Net weight	2 kg (4.3 lbs.)



Hammer Drill HP1230



Continuous rating Input	400W
Blows per minute	0 - 31,900 min ⁻¹
No load speed	0 - 2,900 min ⁻¹
Capacity	Concrete: 12 mm (15/32") Masonry: 12 mm (15/32") Steel: 10 mm (3/8") Wood: 15 mm (9/16") Wood (Self-feed bit): 30 mm (1-3/16")
Chuck capacity	1.5 - 10 mm (1/16 - 3/8")
Dimensions (L x W x H)	239 x 67 x 188 mm (9-3/8 x 2-5/8 x 7-3/8")
Net weight	1.7 kg (3.7 lbs.)



Hammer Drill HP1641F



Continuous rating Input	680W
Blows per minute	0 - 44,800 min ⁻¹
No load speed	0 - 2,800 min ⁻¹
Capacity	Concrete: 16 mm (5/8") Masonry: 16 mm (5/8") Steel: 13 mm (1/2") Wood: 30 mm (1-3/16") Wood (Self-feed bit): 60 mm (2-3/8")
Chuck capacity	1.5 - 13 mm (1/16 - 1/2")
Dimensions (L x W x H)	303 x 72 x 222 mm (11-7/8 x 2-13/16 x 8-3/4")
Net weight	2 kg (4.3 lbs.)



Hammer Drill HP1640



Continuous rating Input	680W
Blows per minute	0 - 44,800 min ⁻¹
No load speed	0 - 2,800 min ⁻¹
Capacity	Concrete: 16 mm (5/8") Masonry: 16 mm (5/8") Steel: 13 mm (1/2") Wood: 30 mm (1-3/16") Wood (Self-feed bit): 60 mm (2-3/8")
Chuck capacity	1.5 - 13 mm (1/16 - 1/2")
Dimensions (L x W x H)	303 x 72 x 222 mm (11-7/8 x 2-13/16 x 8-3/4")
Net weight	2 kg (4.4 lbs.)



Diamond Core Hammer Drill 8406



Continuous rating Input	850W
Impacts per minute	0 - 22,500 min ⁻¹
No load speed	0 - 1,500 min ⁻¹
Capacity	Concrete (w/ Diamond core bit): 152 mm (6") Masonry: 20 mm (13/16") Steel: 13 mm (1/2") Wood: 30 mm (1-3/16") Wood (Self-feed bit): 30 mm (1-3/16")
Chuck capacity	2 - 13 mm (1/16 - 1/2")
Overall length	400 mm (15-3/4")
Net weight	3.7 kg (8.1 lbs.)



Comparison List

Model No.	Powers	Impact energy (EPTA-Procedure 05/2009)	Net weight (kg)	AVT	Soft No load
-----------	--------	--	-----------------	-----	--------------

Cordless Breaker

28.6mm Hex Shank

HM004G	40Vmax x2	72.8 J	29.7 - 32.1 kg (65.5 - 70.8 lbs.)	●	●
--------	-----------	--------	-----------------------------------	---	---

Model No.	Powered	Impact energy (EPTA-Procedure 05/2009)	Net weight (kg)	AVT	Soft No load
-----------	---------	--	-----------------	-----	--------------

Cordless Demolition Hammer

SDS-MAX Shank

HM002G	40Vmax x2	20.9 J	12.0 - 13.3 kg (26.5 - 29.3 lbs.)	●	●
HM001G	40Vmax	9.4 J	6.3 - 7.1 kg (13.9 - 15.7 lbs.)	●	●

Model No.	Continuous rating Input (W)	Impact energy (EPTA-Procedure 05/2009)	Net weight (kg)	AVT	Soft No load
-----------	-----------------------------	--	-----------------	-----	--------------

Demolition Hammer / Electric Breaker

SDS-MAX Shank

HM1214C	1,510	19.9	12.3 kg (27.1 lbs)	●	●
HM1205C	1,510	19.1	9.7 kg (21.5 lbs)	-	-
HM1203C	1,510	19.1	9.7 kg (21.5 lbs)	-	-
HM1213C	1,510	18.6	10.8 kg (23.7 lbs)	●	●
HM1101C	1,300	11.5	7.2 - 7.3 kg (15.8 - 16.1 lbs)	-	-
HM1111C	1,300	11.2	7.8 - 8.0 kg (17.3 - 17.6 lbs)	●	●
HM0871C	1,100	8.1	5.6 - 5.8 kg (12.4 - 12.8 lbs)	●	●
HM0870C	1,100	7.6	5.1 - 5.3 kg (11.1 - 11.6 lbs)	-	-

30mm Hex Shank

HM1306	1,510	21.7	15.1 kg (33.3 lbs)	-	-
HM1317C	1,510	25	17.0 kg (37.5 lbs)	●	●
HM1307C	1,510	25.5	15.3 kg (33.8 lbs)	-	-
HM1511	1,850	48.9	19.2 kg (42.3 lbs.)	●	●
HM1501	1,850	48.1	18.4 kg (40.6 lbs.)	-	-

28.6mm Hex Shank

HM1812	2,000	72.8	31.3 kg (69 lbs)	●	●
HM1802	2,000	71.4	29.4 kg (64.8 lbs)	-	-
HM1512	1,850	48.5	20.4 kg (45.0 lbs.)	●	●
HM1502	1,850	49.1	19.7 kg (43.4 lbs.)	-	-
HM1317CB	1,510	26.5	19.0 kg (41.9 lbs)	●	●
HM1307CB	1,510	23.6	17.3 kg (38.2 lbs)	-	-

21mm Hex Shank

HM1201	1,130	-	9.1 kg (20.1 lbs)	-	-
--------	-------	---	-------------------	---	---

19mm Hex Shank

HM0810B	420	5.3	6.6 kg (14.5 lbs)	-	-
---------	-----	-----	-------------------	---	---















17mm Hex Shank

HM0830	1,010	-	4.9 kg (10.7 lbs)	-	-
HM0810	900	-	6.7 kg (14.7 lbs)	-	-
HM0810T	900	7.2	6.3 kg (13.9 lbs.)	-	-

PRODUCTS

Grinding/Sanding/Polishing



-  Double Insulation
-  Variable Speed
-  Brake
-  Anti-restart function
-  Mechanical 2-Speed
-  Electronic 2-Speed
-  Electronic 3-Speed
-  Torque Limiter
-  Constant Speed
-  Soft Start
-  Hook & Loop
-  Dust Collection
-  Toolless blade change
-  Built-in Job Light
-  Carrying Case

Cordless Angle Grinder

40V max



XGT **BL** **AFT** **XPT**



	GA003G	GA004G	GA005G
Wheel diameter	100 mm (4")	115 mm (4-1/2")	125 mm (5")
No load speed	8,500 min ⁻¹	8,500 min ⁻¹	8,500 min ⁻¹
Dimensions (L x W x H)	w/ BL4040: 410 x 117 x 162 mm (16-1/8 x 4-5/8 x 6-3/8")	w/ BL4040: 410 x 130 x 168 mm (16-1/8 x 5-1/8 x 6-5/8")	w/ BL4040: 410 x 140 x 168 mm (16-1/8 x 5-1/2 x 6-5/8")
Net weight	2.8 - 3.3 kg (6.2 - 7.3 lbs.)	2.9 - 3.5 kg (6.4 - 7.7 lbs.)	2.9 - 3.6 kg (6.4 - 7.9 lbs.)

Cordless Angle Grinder

40V max



XGT **BL** **AFT** **XPT**



	GA006G	GA007G	GA008G
Wheel diameter	100 mm (4")	115 mm (4-1/2")	125 mm (5")
No load speed	8,500 min ⁻¹	8,500 min ⁻¹	8,500 min ⁻¹
Dimensions (L x W x H)	w/ BL4040: 410 x 117 x 158 mm (16-1/8 x 4-5/8 x 6-1/4")	w/ BL4040: 410 x 130 x 165 mm (16-1/8 x 5-1/8 x 6-1/2")	w/ BL4040: 410 x 140 x 165 mm (16-1/8 x 5-1/2 x 6-1/2")
Net weight	2.7 - 3.3 kg (6.0 - 7.3 lbs.)	2.9 - 3.5 kg (6.4 - 7.7 lbs.)	2.9 - 3.5 kg (6.4 - 7.7 lbs.)

Cordless Angle Grinder

40V max



XGT **BL** **AFT** **XPT**



	GA011G	GA012G	GA013G
Wheel diameter	100 mm (4")	115 mm (4-1/2")	125 mm (5")
No load speed	8,500 min ⁻¹	8,500 min ⁻¹	8,500 min ⁻¹
Dimensions (L x W x H)	w/ BL4040: 410 x 117 x 162 mm (16-1/8 x 4-5/8 x 6-3/8")	w/ BL4040: 410 x 130 x 168 mm (16-1/8 x 5-1/8 x 6-5/8")	w/ BL4040: 410 x 140 x 168 mm (16-1/8 x 5-1/2 x 6-5/8")
Net weight	2.8 - 3.4 kg (6.2 - 7.5 lbs.)	3.0 - 3.6 kg (6.6 - 7.9 lbs.)	3.0 - 3.6 kg (6.6 - 7.9 lbs.)

Cordless Angle Grinder

40V max



XGT **BL** **AFT** **XPT**



	GA014G	GA015G	GA016G
Wheel diameter	100 mm (4")	115 mm (4-1/2")	125 mm (5")
No load speed	8,500 min ⁻¹	8,500 min ⁻¹	8,500 min ⁻¹
Dimensions (L x W x H)	w/ BL4040: 410 x 117 x 158 mm (16-1/8 x 4-5/8 x 6-1/4")	w/ BL4040: 410 x 130 x 165 mm (16-1/8 x 5-1/8 x 6-1/2")	w/ BL4040: 410 x 140 x 165 mm (16-1/8 x 5-1/2 x 6-1/2")
Net weight	2.8 - 3.3 kg (6.2 - 7.3 lbs.)	2.9 - 3.5 kg (6.4 - 7.7 lbs.)	2.9 - 3.6 kg (6.4 - 7.9 lbs.)

Cordless Angle Grinder

40V max



XGT **BL** **AFT** **AWS** **XPT**



	GA021G	GA022G	GA023G
Wheel diameter	100 mm (4")	115 mm (4-1/2")	125 mm (5")
No load speed	3,000 - 8,500 min ⁻¹	3,000 - 8,500 min ⁻¹	3,000 - 8,500 min ⁻¹
Dimensions (L x W x H)	w/ BL4040: 425 x 117 x 162 mm (16-3/4 x 4-5/8 x 6-3/8")	w/ BL4040: 425 x 130 x 168 mm (16-3/4 x 5-1/8 x 6-5/8")	w/ BL4040: 425 x 140 x 168 mm (16-3/4 x 5-1/2 x 6-5/8")
Net weight	2.8 - 3.4 kg (6.2 - 7.5 lbs.)	3.0 - 3.6 kg (6.6 - 7.9 lbs.)	3.0 - 4.4 kg (6.6 - 9.7 lbs.)

Cordless Angle Grinder

40V max



XGT **BL** **AFT** **AWS** **XPT**



	GA024G	GA025G	GA026G
Wheel diameter	100 mm (4")	115 mm (4-1/2")	125 mm (5")
No load speed	3,000 - 8,500 min ⁻¹	3,000 - 8,500 min ⁻¹	3,000 - 8,500 min ⁻¹
Dimensions (L x W x H)	w/ BL4040: 425 x 117 x 158 mm (16-3/4 x 4-5/8 x 6-1/4")	w/ BL4040: 425 x 130 x 165 mm (16-3/4 x 5-1/8 x 6-1/2")	w/ BL4040: 425 x 140 x 165 mm (16-3/4 x 5-1/2 x 6-1/2")
Net weight	2.8 - 3.4 kg (6.2 - 7.5 lbs.)	2.9 - 3.5 kg (6.4 - 7.7 lbs.)	2.9 - 4.4 kg (6.4 - 9.7 lbs.)

Cordless Angle Grinder

40V max



XGT **BL** **AFT** **AWS** **XPT**



	GA027G	GA028G	GA029G
Wheel diameter	100 mm (4")	115 mm (4-1/2")	125 mm (5")
No load speed	3,000 - 8,500 min ⁻¹	3,000 - 8,500 min ⁻¹	3,000 - 8,500 min ⁻¹
Dimensions (L x W x H)	w/ BL4040: 425 x 117 x 162 mm (16-3/4 x 4-5/8 x 6-3/8")	w/ BL4040: 425 x 130 x 168 mm (16-3/4 x 5-1/8 x 6-5/8")	w/ BL4040: 425 x 140 x 168 mm (16-3/4 x 5-1/2 x 6-5/8")
Net weight	2.9 - 3.4 kg (6.4 - 7.5 lbs.)	3.0 - 3.6 kg (6.6 - 7.9 lbs.)	3.0 - 4.5 kg (6.6 - 9.9 lbs.)

Grinding/Sanding/Polishing

Cordless Angle Grinder

40V max



XGT **BL** **AFT** **AWS** **XPT**



	GA030G	GA031G	GA032G
Wheel diameter	100 mm (4")	115 mm (4-1/2")	125 mm (5")
No load speed	3,000 - 8,500 min ⁻¹	3,000 - 8,500 min ⁻¹	3,000 - 8,500 min ⁻¹
Dimensions (L x W x H)	w/ BL4040: 425 x 117 x 158 mm (16-3/4 x 4-5/8 x 6-1/4")	w/ BL4040: 425 x 130 x 165 mm (16-3/4 x 5-1/8 x 6-1/2")	w/ BL4040: 425 x 140 x 165 mm (16-3/4 x 5-1/2 x 6-1/2")
Net weight	2.8 - 3.4 kg (6.2 - 7.5 lbs.)	2.9 - 3.6 kg (6.4 - 7.9 lbs.)	3.0 - 4.4 kg (6.6 - 9.7 lbs.)

Cordless Angle Grinder

40V max



XGT **BL** **AFT** **AWS** **XLock** **XPT**



	GA039G	GA040G	GA041G
Wheel diameter	100 mm (4")	115 mm (4-1/2")	125 mm (5")
No load speed	3,000 - 8,500 min ⁻¹	3,000 - 8,500 min ⁻¹	3,000 - 8,500 min ⁻¹
Dimensions (L x W x H)	w/ BL4050F: 459 x 117 x 178 mm (18 x 4-5/8 x 7")	w/ BL4050F: 459 x 130 x 180 mm (18 x 5-1/8 x 7-1/8")	w/ BL4050F: 459 x 140 x 180 mm (18 x 5-1/2 x 7-1/8")
Net weight	3.0 - 5.3 kg (6.6 - 11.7 lbs.)	3.0 - 5.3 kg (6.6 - 11.7 lbs.)	3.0 - 5.3 kg (6.6 - 11.7 lbs.)

Cordless Angle Grinder

40V max



XGT **BL** **AFT** **AWS** **XLock** **XPT**



	GA042G	GA043G	GA044G
Wheel diameter	100 mm (4")	115 mm (4-1/2")	125 mm (5")
No load speed	3,000 - 8,500 min ⁻¹	3,000 - 8,500 min ⁻¹	3,000 - 8,500 min ⁻¹
Dimensions (L x W x H)	w/ BL4050F: 459 x 117 x 178 mm (18 x 4-5/8 x 7")	w/ BL4050F: 459 x 130 x 180 mm (18 x 5-1/8 x 7-1/8")	w/ BL4050F: 459 x 140 x 180 mm (18 x 5-1/2 x 7-1/8")
Net weight	3.0 - 5.4 kg (6.6 - 11.9 lbs.)	3.0 - 5.4 kg (6.6 - 11.9 lbs.)	3.0 - 5.4 kg (6.6 - 11.9 lbs.)

Cordless Angle Grinder

40V max



XGT **BL** **AFT** **XLock** **XPT**



	GA045G	GA046G	GA047G
Wheel diameter	100 mm (4")	115 mm (4-1/2")	125 mm (5")
No load speed	8,500 min ⁻¹	8,500 min ⁻¹	8,500 min ⁻¹
Dimensions (L x W x H)	w/ BL4050F: 444 x 117 x 178 mm (17-1/2 x 4-5/8 x 7")	w/ BL4050F: 444 x 130 x 180 mm (17-1/2 x 5-1/8 x 7-1/8")	w/ BL4050F: 444 x 140 x 180 mm (17-1/2 x 5-1/2 x 7-1/8")
Net weight	2.9 - 5.3 kg (6.4 - 11.7 lbs.)	3.0 - 5.3 kg (6.6 - 11.7 lbs.)	3.0 - 5.3 kg (6.6 - 11.7 lbs.)

Cordless Angle Grinder

40V max



XGT **BL** **AFT** **XPT**



	GA048G	GA049G	GA050G	GA051G
Wheel diameter	100 mm (4")	115 mm (4-1/2")	125 mm (5")	150 mm (6")
No load speed	11,000 min ⁻¹	11,000 min ⁻¹	11,000 min ⁻¹	9,000 min ⁻¹
Dimensions (L x W x H)	w/ BL4040F: 411 x 117 x 162 mm (16-1/8 x 4-5/8 x 6-3/8")	w/ BL4040F: 411 x 130 x 169 mm (16-1/8 x 5-1/8 x 6-5/8")	w/ BL4040F: 411 x 140 x 169 mm (16-1/8 x 5-1/2 x 6-5/8")	w/ BL4040F: 411 x 171 x 169 mm (16-1/8 x 6-3/4 x 6-5/8")
Net weight	2.8 - 5.2 kg (6.2 - 11.5 lbs.)	3.0 - 5.4 kg (6.6 - 11.9 lbs.)	3.0 - 5.4 kg (6.6 - 11.9 lbs.)	3.1 - 4.7 kg (6.8 - 10.4 lbs.)

Cordless Angle Grinder

40V max



XGT **BL** **AFT** **AWS** **XPT**



	GA037G	GA038G
Wheel diameter	180 mm (7")	230 mm (9")
No load speed	7,800 min ⁻¹	6,600 min ⁻¹
Dimensions (L x W x H)	w/ BL4050F: 535 x 200 x 180 mm (21 x 7-7/8 x 7-1/8")	w/ BL4050F: 535 x 250 x 180 mm (21 x 9-7/8 x 7-1/8")
Net weight	4.4 - 5.4 kg (9.7 - 11.9 lbs.)	4.6 - 7.4 kg (10.1 - 16.3 lbs.)

Cordless Angle Grinder

40V max



GA035G: Slide switch

XGT **BL** **AFT** **XPT**



GA036G: Paddle switch

	GA035G	GA036G
Wheel diameter	150 mm (6")	150 mm (6")
No load speed	8,500 min ⁻¹	8,500 min ⁻¹
Dimensions (L x W x H)	w/ BL4040: 410 x 171 x 168 mm (16-1/8 x 6-3/4 x 6-5/8")	w/ BL4040: 410 x 171 x 168 mm (16-1/8 x 6-3/4 x 6-5/8")
Net weight	3.0 - 3.7 kg (6.6 - 8.2 lbs.)	3.0 - 3.7 kg (6.6 - 8.2 lbs.)

Grinding/Sanding/Polishing

Cordless Angle Grinder

18V x2



DGA701 / DGA901

LXT **BL** **ADT** **AFT** **AWS** **XPT**



	DGA700	DGA701	DGA900	DGA901
Wheel diameter	180 mm (7")	180 mm (7")	230 mm (9")	230 mm (9")
No load speed	7,800 min ⁻¹	7,800 min ⁻¹	6,000 min ⁻¹	6,000 min ⁻¹
Dimensions (L x W x H)	499 x 200 x 158 mm (19-5/8 x 7-7/8 x 6-1/4")	499 x 200 x 158 mm (19-5/8 x 7-7/8 x 6-1/4")	499 x 250 x 158 mm (19-5/8 x 9-7/8 x 6-1/4")	499 x 250 x 158 mm (19-5/8 x 9-7/8 x 6-1/4")
Net weight	5.0 - 6.0 kg (11.02 - 13.23 lbs.)	5.0 - 6.0 kg (11.0 - 13.3 lbs.)	5.2 - 8 kg (11.46 - 17.64 lbs.)	5.2 - 8.0 kg (11.4 - 17.7 lbs.)

Cordless Angle Grinder

18V



LXT **BL** **ADT** **AFT** **AWS** **XPT**



	DGA414	DGA514
Wheel diameter	100 mm (4")	125 mm (5")
No load speed	3,000 - 8,500 min ⁻¹	3,000 - 8,500 min ⁻¹
Dimensions (L x W x H)	w/ BL1830B / BL1840B / BL1850B / BL1860B: 382 x 117 x 147 mm (15 x 4-5/8 x 5-3/4")	w/ BL1830B / BL1840B / BL1850B / BL1860B: 382 x 140 x 151 mm (15 x 5-1/2 x 5-15/16")
Net weight	2.2 - 2.8 kg (4.9 - 6.3 lbs.)	2.4 - 3 kg (5.2 - 6.7 lbs.)

Cordless Angle Grinder

18V



LXT **BL** **ADT** **AFT** **XPT**



	DGA413	DGA463	DGA513
Wheel diameter	100 mm (4")	115 mm (4-1/2")	125 mm (5")
No load speed	3,000 - 8,500 min ⁻¹	3,000 - 8,500 min ⁻¹	3,000 - 8,500 min ⁻¹
Dimensions (L x W x H)	w/ BL1830B / BL1840B / BL1850B / BL1860B: 382 x 117 x 147 mm (15 x 4-5/8 x 5-3/4")	w/ BL1830B / BL1840B / BL1850B / BL1860B: 382 x 130 x 151 mm (15 x 5-1/8 x 5-15/16")	w/ BL1830B / BL1840B / BL1850B / BL1860B: 382 x 140 x 151 mm (15 x 5-1/2 x 5-15/16")
Net weight	2.2 - 2.8 kg (4.9 - 6.2 lbs.)	2.3 - 3 kg (5.1 - 6.7 lbs.)	2.4 - 3 kg (5.2 - 6.7 lbs.)

Cordless Angle Grinder

18V



LXT **BL** **ADT** **AFT** **AWS** **XPT**



	DGA412	DGA512
Wheel diameter	100 mm (4")	125 mm (5")
No load speed	3,000 - 8,500 min ⁻¹	3,000 - 8,500 min ⁻¹
Dimensions (L x W x H)	w/ BL1830B / BL1840B / BL1850B / BL1860B: 382 x 117 x 140 mm (15 x 4-5/8 x 5-1/2")	w/ BL1830B / BL1840B / BL1850B / BL1860B: 382 x 140 x 145 mm (15 x 5-1/2 x 5-3/4")
Net weight	2.2 - 2.8 kg (4.8 - 6.1 lbs.)	2.3 - 3 kg (5.2 - 6.6 lbs.)

Cordless Angle Grinder

18V



LXT **BL** **ADT** **AFT** **XPT**



	DGA411	DGA511
Wheel diameter	100 mm (4")	125 mm (5")
No load speed	3,000 - 8,500 min ⁻¹	3,000 - 8,500 min ⁻¹
Dimensions (L x W x H)	w/ BL1830B / BL1840B / BL1850B / BL1860B: 382 x 117 x 140 mm (15 x 4-5/8 x 5-1/2")	w/ BL1830B / BL1840B / BL1850B / BL1860B: 382 x 140 x 145 mm (15 x 5-1/2 x 5-3/4")
Net weight	2.2 - 2.8 kg (4.8 - 6.1 lbs.)	2.3 - 3 kg (5.1 - 6.6 lbs.)

Cordless Angle Grinder

18V



LXT **BL** **ADT** **AFT** **XPT**



	DGA406	DGA456	DGA506
Wheel diameter	100 mm (4")	115 mm (4-1/2")	125 mm (5")
No load speed	8,500 min ⁻¹	8,500 min ⁻¹	8,500 min ⁻¹
Dimensions (L x W x H)	362 x 117 x 146 mm (14-1/4 x 4-5/8 x 5-3/4")	362 x 130 x 151 mm (14-1/4 x 5-1/8 x 5-15/16")	362 x 140 x 151 mm (14-1/4 x 5-1/2 x 5-15/16")
Net weight	2.18 - 2.77 kg (4.81 - 6.12 lbs.)	2.34 - 3.03 kg (5.17 - 6.67 lbs.)	2.35 - 3.83 kg (5.18 - 8.45 lbs.)

Cordless Angle Grinder

18V



DGA521

LXT **BL** **ADT** **AFT** **XLock** **XPT**



	DGA404	DGA454	DGA504	DGA521
Wheel diameter	100 mm (4")	115 mm (4-1/2")	125 mm (5")	125 mm (5")
No load speed	8,500 min ⁻¹	8,500 min ⁻¹	8,500 min ⁻¹	8,500 min ⁻¹
Dimensions (L x W x H)	362 x 117 x 140 mm (14-1/4 x 4-5/8 x 5-1/2")	362 x 130 x 145 mm (14-1/4 x 5-1/8 x 5-3/4")	362 x 140 x 145 mm (14-1/4 x 5-1/2 x 5-3/4")	w/ BL1830B / BL1840B / BL1850B / BL1860B: 375 x 140 x 146 mm (14-3/4 x 5-1/2 x 5-3/4")
Net weight	2.1 - 2.71 kg (4.63 - 5.98 lbs.)	2.24 - 2.89 kg (4.93 - 6.37 lbs.)	2.26 - 3.73 kg (4.98 - 8.23 lbs.)	2.4 - 3.0 kg (5.3 - 6.6 lbs.)

The weight may differ depending on the attachment(s), including the battery cartridge.

Grinding/Sanding/Polishing

Cordless Angle Grinder

18V



LXT



	DGA402	DGA452
Wheel diameter	100 mm (4")	115 mm (4-1/2")
No load speed	11,000 min ⁻¹	11,000 min ⁻¹
Dimensions (L x W x H)	317 x 118 x 118 mm (12-1/2 x 4-5/8 x 4-5/8")	317 x 129 x 126 mm (12-1/2 x 5-1/8 x 5")
Net weight	1.9 - 2.51 kg (4.19 - 5.54 lbs.)	2.06 - 2.71 kg (4.53 - 5.97 lbs.)

Cordless Angle Grinder

18V



LXT BL ADT AFT AWS XPT



	DGA418	DGA518
Wheel diameter	100 mm (4")	125 mm (5")
No load speed	3,000 - 8,500 min ⁻¹	3,000 - 8,500 min ⁻¹
Dimensions (L x W x H)	w/ BL1830B / BL1840B / BL1850B / BL1860B: 382 x 117 x 146 mm (15 x 4-5/8 x 5-3/4")	w/ BL1830B / BL1840B / BL1850B / BL1860B: 382 x 140 x 151 mm (15 x 5-1/2 x 6")
Net weight	2.2 - 2.9 kg (5 - 6.3 lbs.)	2.4 - 3.1 kg (5.3 - 6.8 lbs.)

Cordless Angle Grinder

18V



LXT BL ADT AFT XPT



	DGA417	DGA467	DGA517
Wheel diameter	100 mm (4")	115 mm (4-1/2")	125 mm (5")
No load speed	3,000 - 8,500 min ⁻¹	3,000 - 8,500 min ⁻¹	3,000 - 8,500 min ⁻¹
Dimensions (L x W x H)	w/ BL1830B / BL1840B / BL1850B / BL1860B: 382 x 117 x 146 mm (15 x 4-5/8 x 5-3/4")	w/ BL1830B / BL1840B / BL1850B / BL1860B: 382 x 130 x 151 mm (15 x 5-1/8 x 6")	w/ BL1830B / BL1840B / BL1850B / BL1860B: 382 x 140 x 151 mm (15 x 5-1/2 x 6")
Net weight	2.2 - 2.9 kg (4.9 - 6.3 lbs.)	2.4 - 3.1 kg (5.2 - 6.7 lbs.)	2.4 - 3.1 kg (5.2 - 6.7 lbs.)

Cordless Angle Grinder

18V



LXT BL ADT AFT XLock XPT



	DGA419	DGA469	DGA519
Wheel diameter	100 mm (4")	115 mm (4-1/2")	125 mm (5")
No load speed	3,000 - 8,500 min ⁻¹	3,000 - 8,500 min ⁻¹	3,000 - 8,500 min ⁻¹
Dimensions (L x W x H)	w/ BL1830B / BL1840B / BL1850B / BL1860B: 396 x 117 x 147 mm (15-1/2 x 4-5/8 x 5-3/4")	w/ BL1830B / BL1840B / BL1850B / BL1860B: 396 x 130 x 147 mm (15-1/2 x 5-1/8 x 5-3/4")	w/ BL1830B / BL1840B / BL1850B / BL1860B: 396 x 140 x 147 mm (15-1/2 x 5-1/2 x 5-3/4")
Net weight	2.4 - 3.0 kg (5.3 - 6.6 lbs.)	2.5 - 3.1 kg (5.5 - 6.8 lbs.)	2.5 - 3.1 kg (5.5 - 6.8 lbs.)

Cordless Angle Grinder

18V



LXT BL ADT AFT XPT



	DGA408	DGA458	DGA508
Wheel diameter	100 mm (4")	115 mm (4-1/2")	125 mm (5")
No load speed	8,500 min ⁻¹	8,500 min ⁻¹	8,500 min ⁻¹
Dimensions (L x W x H)	362 x 117 x 146 mm (14-1/4 x 4-5/8 x 5-3/4")	362 x 130 x 151 mm (14-1/4 x 5-1/8 x 5-15/16")	362 x 140 x 151 mm (14-1/4 x 5-1/2 x 5-15/16")
Net weight	2.18 - 2.8 kg (4.81 - 6.17 lbs.)	2.34 - 3.03 kg (5.17 - 6.67 lbs.)	2.35 - 3.83 kg (5.18 - 8.45 lbs.)

Cordless Angle Grinder

18V



DGA520

LXT BL ADT AFT XLock XPT



▲ DGA520

	DGA405	DGA455	DGA505	DGA520
Wheel diameter	100 mm (4")	115 mm (4-1/2")	125 mm (5")	125 mm (5")
No load speed	8,500 min ⁻¹	8,500 min ⁻¹	8,500 min ⁻¹	8,500 min ⁻¹
Dimensions (L x W x H)	362 x 117 x 140 mm (14-1/4 x 4-5/8 x 5-1/2")	362 x 130 x 145 mm (14-1/4 x 5-1/8 x 5-3/4")	362 x 140 x 145 mm (14-1/4 x 5-1/2 x 5-3/4")	w/ BL1830B / BL1840B / BL1850B / BL1860B: 376 x 140 x 147 mm (14-3/4 x 5-1/2 x 5-3/4")
Net weight	2.08 - 2.69 kg (4.59 - 5.94 lbs.)	2.24 - 2.92 kg (4.93 - 6.45 lbs.)	2.26 - 3.73 kg (4.98 - 8.23 lbs.)	2.4 - 3.0 kg (5.3 - 6.6 lbs.)

Angle Grinder



AFT SYSTEM



	GA4590	GA5090
Continuous rating Input	1,900W	1,900W
Wheel diameter	115 mm (4-1/2")	125 mm (5")
No load speed	2,800 - 11,500 min ⁻¹	2,800 - 11,500 min ⁻¹
Circumference of grip portion	205 mm (8-1/8")	205 mm (8-1/8")
Cutting depth	26 mm (1")	31 mm (1-1/4")
Dimensions (L x W x H)	326 x 130 x 123 mm (12-7/8 x 5-1/8 x 4-7/8")	326 x 130 x 123 mm (12-7/8 x 5-1/8 x 4-7/8")
Net weight	2.6 - 3.8 kg (5.7 - 8.4 lbs.)	2.6 - 3.8 kg (5.7 - 8.4 lbs.)

Angle Grinder



AFT **SYSTEM**



	GA4591	GA5091
Continuous rating Input	1,900W	1,900W
Wheel diameter	115 mm (4-1/2")	125 mm (5")
No load speed	2,800 - 11,500 min ⁻¹	2,800 - 11,500 min ⁻¹
Circumference of grip portion	205 mm (8-1/8")	205 mm (8-1/8")
Cutting depth	26 mm (1")	31 mm (1-1/4")
Dimensions (L x W x H)	349 x 130 x 129 mm (13-3/4 x 5-1/8 x 5-1/8")	349 x 140 x 129 mm (13-3/4 x 5-1/2 x 5-1/8")
Net weight	2.8 - 4.0 kg (6.2 - 8.8 lbs.)	2.8 - 4.0 kg (6.2 - 8.8 lbs.)

Angle Grinder



AFT **SYSTEM**



	GA4592	GA5092
Continuous rating Input	1,900W	1,900W
Wheel diameter	115 mm (4-1/2")	125 mm (5")
No load speed	11,500 min ⁻¹	11,500 min ⁻¹
Circumference of grip portion	205 mm (8-1/8")	205 mm (8-1/8")
Cutting depth	26 mm (1")	31 mm (1-1/4")
Dimensions (L x W x H)	326 x 130 x 123 mm (12-7/8 x 5-1/8 x 4-7/8")	326 x 140 x 123 mm (12-7/8 x 5-1/2 x 4-7/8")
Net weight	2.6 - 3.8 kg (5.7 - 8.4 lbs.)	2.6 - 5.7 kg (5.7 - 8.4 lbs.)

Angle Grinder



AFT **SYSTEM**



	GA4593	GA5093
Continuous rating Input	1,900W	1,900W
Wheel diameter	115 mm (4-1/2")	125 mm (5")
No load speed	2,800 - 11,500 min ⁻¹	2,800 - 11,500 min ⁻¹
Circumference of grip portion	207 mm (8-1/8")	207 mm (8-1/8")
Cutting depth	26 mm (1")	31 mm (1-1/4")
Dimensions (L x W x H)	349 x 130 x 129 mm (13-3/4 x 5-1/8 x 5-1/8")	349 x 140 x 129 mm (13-3/4 x 5-1/2 x 5-1/8")
Net weight	2.8 - 4.0 kg (6.2 - 8.8 lbs.)	2.9 - 4.0 kg (6.4 - 8.8 lbs.)

Angle Grinder



AFT **SYSTEM**



	GA4594	GA5094
Continuous rating Input	1,900W	1,900W
Wheel diameter	115 mm (4-1/2")	125 mm (5")
No load speed	11,500 min ⁻¹	11,500 min ⁻¹
Circumference of grip portion	207 mm (8-1/8")	207 mm (8-1/8")
Cutting depth	26 mm (1")	31 mm (1-1/4")
Dimensions (L x W x H)	349 x 130 x 129 mm (13-3/4 x 5-1/8 x 5-1/8")	349 x 140 x 129 mm (13-3/4 x 5-1/2 x 5-1/8")
Net weight	2.8 - 4.0 kg (6.2 - 8.8 lbs.)	2.9 - 4.0 kg (6.4 - 8.8 lbs.)

Angle Grinder



AFT **SYSTEM**



	GA4595	GA5095
Continuous rating Input	1,900W	1,900W
Wheel diameter	115 mm (4-1/2")	125 mm (5")
No load speed	11,500 min ⁻¹	11,500 min ⁻¹
Circumference of grip portion	207 mm (8-1/8")	207 mm (8-1/8")
Cutting depth	26 mm (1")	31 mm (1-1/4")
Dimensions (L x W x H)	326 x 130 x 123 mm (12-7/8 x 5-1/8 x 4-7/8")	326 x 140 x 123 mm (12-7/8 x 5-1/2 x 4-7/8")
Net weight	2.6 - 3.8 kg (5.7 - 8.4 lbs.)	2.6 - 3.8 kg (5.7 - 8.4 lbs.)

Angle Grinder



HYPER-DRIVE SYSTEM
SJS



	GA5021C	GA6021C
Continuous rating Input	1,450W	1,450W
Wheel diameter	125 mm (5")	150 mm (6")
No load speed	10,000 min ⁻¹	9,000 min ⁻¹
Dimensions (L x W x H)	390 x 139 x 120 mm (15-3/8 x 5-1/2 x 4-3/4")	390 x 169 x 120 mm (15-3/8 x 6-5/8 x 4-3/4")
Net weight	2.9 - 4.1 kg (6.5 - 9.1 lbs.)	3 - 3.5 kg (6.7 - 7.6 lbs.)

Angle Grinder



HYPER-DRIVE SYSTEM
SJS



	GA5020C	GA6020C
Continuous rating Input	1,450W	1,450W
Wheel diameter	125 mm (5")	150 mm (6")
No load speed	10,000 min ⁻¹	9,000 min ⁻¹
Dimensions (L x W x H)	390 x 139 x 120 mm (15-3/8 x 5-1/2 x 4-3/4")	390 x 169 x 120 mm (15-3/8 x 6-5/8 x 4-3/4")
Net weight	2.9 - 4.1 kg (6.5 - 9.1 lbs.)	3 - 3.5 kg (6.7 - 7.6 lbs.)

Grinding/Sanding/Polishing

Angle Grinder



SJS



GA5041C	
Continuous rating Input	1,400W
Wheel diameter	125 mm (5")
No load speed	2,800 - 11,000 min ⁻¹
Dimensions (L x W x H)	325 x 140 x 121 mm (12-3/4 x 5-1/2 x 4-3/4")
Net weight	2.7 - 3.8 kg (5.9 - 8.4 lbs.)

Angle Grinder



SJS



	GA4040C	GA4540C	GA5040C	GA6040C
Continuous rating Input	1,400W	1,400W	1,400W	1,400W
Wheel diameter	100 mm (4")	115 mm (4-1/2")	125 mm (5")	150 mm (6")
No load speed	2,800 - 11,000 min ⁻¹	2,800 - 11,000 min ⁻¹	2,800 - 11,000 min ⁻¹	4,000 - 9,000 min ⁻¹
Dimensions (L x W x H)	303 x 117 x 111 mm (11-7/8 x 4-5/8 x 4-3/8")	303 x 130 x 116 mm (11-7/8 x 5-1/8 x 4-9/16")	303 x 140 x 116 mm (11-7/8 x 5-1/2 x 4-9/16")	303 x 171 x 116 mm (11-7/8 x 6-3/4 x 4-9/16")
Net weight	2.3 - 2.6 kg (5.1 - 5.7 lbs.)	2.4 - 2.8 kg (5.4 - 6.2 lbs.)	2.5 - 3.6 kg (5.6 - 8 lbs.)	2.5 - 2.9 kg (5.5 - 6.4 lbs.)

Angle Grinder



SJS



	GA4542C	GA5042C	GA6042C
Continuous rating Input	1,400W	1,400W	1,400W
Wheel diameter	115 mm (4-1/2")	125 mm (5")	150 mm (6")
No load speed	2,800 - 11,000 min ⁻¹	2,800 - 11,000 min ⁻¹	4,000 - 9,000 min ⁻¹
Dimensions (L x W x H)	303 x 130 x 116 mm (11-7/8 x 5-1/8 x 4-9/16")	303 x 140 x 116 mm (11-7/8 x 5-1/2 x 4-9/16")	303 x 171 x 116 mm (11-7/8 x 6-3/4 x 4-9/16")
Net weight	2.4 - 2.8 kg (5.2 - 6.2 lbs.)	2.5 - 3.6 kg (5.4 - 8 lbs.)	2.5 - 2.9 kg (5.5 - 6.4 lbs.)

Angle Grinder



SUPER-DRY SYSTEM SJS



	9565CVR	9564CV	9565CV
Continuous rating Input	1,400W	1,400W	1,400W
Wheel diameter	125 mm (5")	115 mm (4-1/2")	125 mm (5")
No load speed	2,800 - 12,000 min ⁻¹	2,800 - 12,000 min ⁻¹	2,800 - 12,000 min ⁻¹
Dimensions (L x W x H)	299 x 139 x 103 mm (11-3/4 x 5-1/2 x 4-1/16")	299 x 129 x 103 mm (11-3/4 x 5-1/16 x 4")	299 x 139 x 103 mm (11-3/4 x 5-1/2 x 4-1/16")
Net weight	2.4 - 3.5 kg (5.2 - 7.7 lbs.)	2.3 - 2.6 kg (5.1 - 5.8 lbs.)	2.4 - 3.5 kg (5.2 - 7.7 lbs.)

Angle Grinder



SUPER-DRY SYSTEM SJS



9565CR	
Continuous rating Input	1,400W
Wheel diameter	125 mm (5")
No load speed	12,000 min ⁻¹
Dimensions (L x W x H)	299 x 139 x 103 mm (11-3/4 x 5-1/2 x 4-1/16")
Net weight	2.4 - 3.5 kg (5.2 - 7.7 lbs.)

Angle Grinder



SUPER-DRY SYSTEM SJS



	9565C	9566C
Continuous rating Input	1,400W	1,400W
Wheel diameter	125 mm (5")	150 mm (6")
No load speed	12,000 min ⁻¹	10,000 min ⁻¹
Dimensions (L x W x H)	299 x 139 x 103 mm (11-3/4 x 5-1/2 x 4-1/16")	299 x 169 x 103 mm (11-3/4 x 6-5/8 x 4-1/16")
Net weight	2.4 - 3.5 kg (5.3 - 7.7 lbs.)	2.5 - 2.8 kg (5.4 - 6.2 lbs.)

Angle Grinder



SUPER-DRY SYSTEM SJS



	9564PCV	9565PCV	9566PCV
Continuous rating Input	1,400W	1,400W	1,400W
Wheel diameter	115 mm (4-1/2")	125 mm (5")	150 mm (6")
No load speed	2,800 - 12,000 min ⁻¹	12,000 min ⁻¹	4,000 - 10,000 min ⁻¹
Dimensions (L x W x H)	307 x 129 x 103 mm (12-1/8 x 5-1/8 x 4")	307 x 139 x 103 mm (12-1/8 x 5-1/2 x 4")	307 x 169 x 103 mm (12-1/8 x 6-5/8 x 4")
Net weight	2.4 - 2.7 kg (5.3 - 5.9 lbs.)	2.4 - 3.5 kg (5.3 - 7.7 lbs.)	2.4 - 2.8 kg (5.3 - 6.2 lbs.)

Grinding/Sanding/Polishing

Angle Grinder



SJS



	9564PC	9565PC	9566PC
Continuous rating Input	1,400W	1,400W	1,400W
Wheel diameter	115 mm (4-1/2")	125 mm (5")	150 mm (6")
No load speed	12,000 min ⁻¹	12,000 min ⁻¹	10,000 min ⁻¹
Dimensions (L x W x H)	307 x 129 x 103 mm (12-1/8 x 5-1/8 x 4")	307 x 139 x 103 mm (12-1/8 x 5-1/2 x 4")	307 x 169 x 103 mm (12-1/8 x 6-5/8 x 4")
Net weight	2.4 - 2.7 kg (5.3 - 6 lbs.)	2.4 - 3.5 kg (5.3 - 7.7 lbs.)	2.4 - 2.8 kg (5.3 - 6.2 lbs.)

Angle Grinder



	GA4050	GA4550	GA5050
Continuous rating Input	1,300W	1,300W	1,300W
Wheel diameter	100 mm (4")	115 mm (4-1/2")	125 mm (5")
No load speed	11,000 min ⁻¹	11,000 min ⁻¹	11,000 min ⁻¹
Circumference of grip portion	212 mm (8-3/8")	212 mm (8-3/8")	212 mm (8-3/8")
Dimensions (L x W x H)	325 x 117 x 100 mm (12-3/4 x 4-5/8 x 4-5/16")	325 x 130 x 117 mm (12-3/4 x 5-1/8 x 4-5/8")	325 x 140 x 117 mm (12-3/4 x 5-1/2 x 4-5/8")
Net weight	2.3 - 2.6 kg (5.1 - 5.7 lbs.)	2.4 - 2.8 kg (5.3 - 6.2 lbs.)	2.5 - 2.8 kg (5.5 - 6.2 lbs.)

Angle Grinder



	GA4552	GA5052
Continuous rating Input	1,300W	1,300W
Wheel diameter	115 mm (4-1/2")	125 mm (5")
No load speed	11,000 min ⁻¹	11,000 min ⁻¹
Circumference of grip portion	212 mm (8-3/8")	212 mm (8-3/8")
Dimensions (L x W x H)	325 x 130 x 117 mm (12-3/4 x 5-1/8 x 4-5/8")	325 x 140 x 117 mm (12-3/4 x 5-1/2 x 4-5/8")
Net weight	2.4 - 2.8 kg (5.3 - 6.2 lbs.)	2.5 - 2.8 kg (5.5 - 6.2 lbs.)

Angle Grinder



	GA4050R	GA4550R	GA5050R
Continuous rating Input	1,300W	1,300W	1,300W
Wheel diameter	100 mm (4")	115 mm (4-1/2")	125 mm (5")
No load speed	11,000 min ⁻¹	11,000 min ⁻¹	11,000 min ⁻¹
Circumference of grip portion	212 mm (8-3/8")	212 mm (8-3/8")	212 mm (8-3/8")
Dimensions (L x W x H)	325 x 117 x 100 mm (12-3/4 x 4-5/8 x 4-5/16")	325 x 130 x 117 mm (12-3/4 x 5-1/8 x 4-5/8")	325 x 140 x 117 mm (12-3/4 x 5-1/2 x 4-5/8")
Net weight	2.3 - 2.6 kg (5.1 - 5.7 lbs.)	2.4 - 2.8 kg (5.3 - 6.2 lbs.)	2.5 - 2.8 kg (5.5 - 6.2 lbs.)

Angle Grinder



	GA4552R	GA5052R
Continuous rating Input	1,300W	1,300W
Wheel diameter	115 mm (4-1/2")	125 mm (5")
No load speed	11,000 min ⁻¹	11,000 min ⁻¹
Circumference of grip portion	212 mm (8-3/8")	212 mm (8-3/8")
Dimensions (L x W x H)	325 x 130 x 117 mm (12-3/4 x 5-1/8 x 4-5/8")	325 x 140 x 117 mm (12-3/4 x 5-1/2 x 4-5/8")
Net weight	2.4 - 2.8 kg (5.3 - 6.2 lbs.)	2.5 - 2.8 kg (5.5 - 6.2 lbs.)

Angle Grinder



	GA4051R	GA4551R	GA5051R
Continuous rating Input	1,300W	1,300W	1,300W
Wheel diameter	100 mm (4")	115 mm (4-1/2")	125 mm (5")
No load speed	11,000 min ⁻¹	11,000 min ⁻¹	11,000 min ⁻¹
Circumference of grip portion	212 mm (8-3/8")	212 mm (8-3/8")	212 mm (8-3/8")
Dimensions (L x W x H)	325 x 117 x 100 mm (12-3/4 x 4-5/8 x 4-5/16")	325 x 130 x 117 mm (12-3/4 x 5-1/8 x 4-5/8")	325 x 140 x 117 mm (12-3/4 x 5-1/2 x 4-5/8")
Net weight	2.3 - 2.5 kg (5.1 - 5.5 lbs.)	2.4 - 2.7 kg (5.3 - 6.0 lbs.)	2.5 - 2.7 kg (5.5 - 6.0 lbs.)

Angle Grinder



	GA4553R	GA5053R
Continuous rating Input	1,300W	1,300W
Wheel diameter	115 mm (4-1/2")	125 mm (5")
No load speed	11,000 min ⁻¹	11,000 min ⁻¹
Circumference of grip portion	212 mm (8-3/8")	212 mm (8-3/8")
Dimensions (L x W x H)	325 x 130 x 117 mm (12-3/4 x 5-1/8 x 4-5/8")	325 x 140 x 117 mm (12-3/4 x 5-1/2 x 4-5/8")
Net weight	2.4 - 2.7 kg (5.3 - 6.0 lbs.)	2.5 - 2.7 kg (5.5 - 6.0 lbs.)

Grinding/Sanding/Polishing

Angle Grinder



SJS



	GA4540R	GA5040R	GA6040R
Continuous rating Input	1,100W	1,100W	1,100W
Wheel diameter	115 mm (4-1/2")	125 mm (5")	150 mm (6")
No load speed	11,000 min ⁻¹	11,000 min ⁻¹	9,000 min ⁻¹
Dimensions (L x W x H)	303 x 130 x 116 mm (11-7/8 x 5-1/8 x 4-9/16")	303 x 140 x 116 mm (11-7/8 x 5-1/2 x 4-9/16")	303 x 171 x 116 mm (11-7/8 x 6-3/4 x 4-9/16")
Net weight	2.4 - 2.8 kg (5.4 - 6.1 lbs.)	2.5 - 3.6 kg (5.4 - 8 lbs.)	2.5 - 2.9 kg (5.5 - 6.4 lbs.)

Angle Grinder



SJS



	GA4040	GA4540	GA5040	GA6040
Continuous rating Input	1,100W	1,100W	1,100W	1,100W
Wheel diameter	100 mm (4")	115 mm (4-1/2")	125 mm (5")	150 mm (6")
No load speed	11,000 min ⁻¹	11,000 min ⁻¹	11,000 min ⁻¹	9,000 min ⁻¹
Dimensions (L x W x H)	303 x 117 x 111 mm (11-7/8 x 4-5/8 x 4-3/8")	303 x 130 x 116 mm (11-7/8 x 5-1/8 x 4-9/16")	303 x 140 x 116 mm (11-7/8 x 5-1/2 x 4-9/16")	303 x 171 x 116 mm (11-7/8 x 6-3/4 x 4-9/16")
Net weight	2.2 - 2.5 kg (4.9 - 5.6 lbs.)	2.3 - 2.7 kg (5.2 - 5.9 lbs.)	2.4 - 3.5 kg (5.2 - 7.8 lbs.)	2.4 - 2.8 kg (5.3 - 6.2 lbs.)

Angle Grinder



SJS



	9565HR
Continuous rating Input	1,100W
Wheel diameter	125 mm (5")
No load speed	12,000 min ⁻¹
Dimensions (L x W x H)	299 x 140 x 111 mm (11-3/4 x 5-1/2 x 4-3/8")
Net weight	2.4 - 3.5 kg (5.2 - 7.6 lbs.)

Angle Grinder



SJS



	9564P
Continuous rating Input	1,100W
Wheel diameter	115 mm (4-1/2")
No load speed	12,000 min ⁻¹
Dimensions (L x W x H)	307 x 129 x 103 mm (12-1/8 x 5-1/8 x 4")
Net weight	2.4 - 2.7 kg (5.3 - 5.9 lbs.)

Angle Grinder



SJS



	GA5021	GA5011	GA6021
Continuous rating Input	1,050W	1,050W	1,050W
Wheel diameter	125 mm (5")	125 mm (5")	150 mm (6")
No load speed	10,000 min ⁻¹	12,000 min ⁻¹	10,000 min ⁻¹
Dimensions (L x W x H)	384 x 139 x 120 mm (15-1/8 x 5-1/2 x 4-3/4")	384 x 139 x 113 mm (15-1/8 x 5-1/2 x 4-7/16")	384 x 172 x 120 mm (15-1/8 x 6-3/4 x 4-3/4")
Net weight	2.7 - 3.9 kg (6 - 8.6 lbs.)	2.6 - 3.8 kg (5.8 - 8.4 lbs.)	2.8 - 3.2 kg (6.1 - 7.1 lbs.)

Angle Grinder



SJS



	GA5020	GA5010	GA6020	GA6010
Continuous rating Input	1,050W	1,050W	1,050W	1,050W
Wheel diameter	125 mm (5")	125 mm (5")	150 mm (6")	150 mm (6")
No load speed	12,000 min ⁻¹	12,000 min ⁻¹	10,000 min ⁻¹	10,000 min ⁻¹
Dimensions (L x W x H)	356 x 139 x 120 mm (14 x 5-1/2 x 4-3/4")	356 x 139 x 112 mm (14 x 5-1/2 x 4-3/8")	356 x 169 x 120 mm (14 x 6-5/8 x 4-3/4")	356 x 169 x 112 mm (14 x 6-5/8 x 4-3/8")
Net weight	2.7 - 3.9 kg (6 - 8.6 lbs.)	2.6 - 3.8 kg (5.8 - 8.4 lbs.)	2.8 - 3.2 kg (6.1 - 7.1 lbs.)	2.7 - 3.1 kg (5.9 - 6.9 lbs.)

Angle Grinder



SJS



	GA5080R	GA5080
Continuous rating Input	1,400W	1,400W
Wheel diameter	125 mm (5")	125 mm (5")
No load speed	12,000 min ⁻¹	12,000 min ⁻¹
Circumference of grip portion	205 mm (8-1/8")	205 mm (8-1/8")
Cutting depth	31 mm (1-1/4")	31 mm (1-1/4")
Dimensions (L x W x H)	309 x 141 x 113 mm (12-1/8 x 5-9/16 x 4-7/16")	309 x 141 x 113 mm (12-1/8 x 5-9/16 x 4-7/16")
Net weight	2.5 - 3.6 kg (5.5 - 7.9 lbs.)	2.5 - 3.6 kg (5.5 - 7.9 lbs.)

Angle Grinder



Lock



GA4570

Continuous rating Input	840W
Wheel diameter	115 mm (4-1/2")
No load speed	11,000 min ⁻¹
Circumference of grip portion	195 mm (7-5/8")
Cutting depth	26 mm (1")
Dimensions (L x W x H)	288 x 131 x 112 mm (11-3/8 x 5-1/8 x 4-3/8")
Net weight	2.2 - 2.5 kg (4.9 - 5.5 lbs.)

Angle Grinder



9556HB

Continuous rating Input	840W
Wheel diameter	100 mm (4")
No load speed	11,000 min ⁻¹
Dimensions (L x W x H)	271 x 118 x 97 mm (10-5/8 x 4-5/8 x 3-13/16")
Net weight	1.6 - 2 kg (3.6 - 4.4 lbs.)

9556HN

Continuous rating Input	840W
Wheel diameter	100 mm (4")
No load speed	11,000 min ⁻¹
Dimensions (L x W x H)	271 x 130 x 97 mm (10-5/8 x 4-5/8 x 3-13/16")
Net weight	1.6 - 2 kg (3.6 - 4.4 lbs.)

9557HN

Continuous rating Input	840W
Wheel diameter	115 mm (4-1/2")
No load speed	11,000 min ⁻¹
Dimensions (L x W x H)	271 x 129 x 106 mm (10-5/8 x 5-1/8 x 4-3/16")
Net weight	1.7 - 2.2 kg (3.8 - 4.8 lbs.)

9558HN

Continuous rating Input	840W
Wheel diameter	125 mm (5")
No load speed	11,000 min ⁻¹
Dimensions (L x W x H)	271 x 139 x 106 mm (10-5/8 x 5-1/2 x 4-3/16")
Net weight	1.7 - 3 kg (3.8 - 6.6 lbs.)

Angle Grinder



9557NBR

Continuous rating Input	840W
Wheel diameter	115 mm (4-1/2")
No load speed	11,000 min ⁻¹
Dimensions (L x W x H)	271 x 130 x 106 mm (10-5/8 x 4-5/8 x 4-3/16")
Net weight	1.7 - 2.4 kg (3.8 - 5.3 lbs.)

9557HNR

Continuous rating Input	840W
Wheel diameter	115 mm (4-1/2")
No load speed	11,000 min ⁻¹
Dimensions (L x W x H)	271 x 130 x 106 mm (10-5/8 x 4-5/8 x 4-3/16")
Net weight	1.7 - 2.4 kg (3.8 - 5.3 lbs.)

9558NBR

Continuous rating Input	840W
Wheel diameter	125 mm (5")
No load speed	11,000 min ⁻¹
Dimensions (L x W x H)	271 x 140 x 106 mm (10-5/8 x 5-1/2 x 4-3/16")
Net weight	1.7 - 3.2 kg (3.8 - 7 lbs.)

9558HNR

Continuous rating Input	840W
Wheel diameter	125 mm (5")
No load speed	11,000 min ⁻¹
Dimensions (L x W x H)	271 x 140 x 106 mm (10-5/8 x 5-1/2 x 4-3/16")
Net weight	1.7 - 3.2 kg (3.8 - 7.1 lbs.)

Angle Grinder

new



9556HNR

Continuous rating Input	840W
Wheel diameter	100 mm (4")
No load speed	11,000 min ⁻¹
Circumference of grip portion	195 mm (7-5/8")
Dimensions (L x W x H)	271 x 118 x 106 mm (10-5/8 x 4-5/8 x 4-3/16")
Net weight	1.9 - 2.9 kg (4.2 - 6.4 lbs.)

Angle Grinder



9556HP

Continuous rating Input	840W
Wheel diameter	100 mm (4")
No load speed	11,000 min ⁻¹
Dimensions (L x W x H)	273 x 118 x 97 mm (10-3/4 x 4-5/8 x 3-13/16")
Net weight	1.7 - 2 kg (3.7 - 4.5 lbs.)

9557HP

Continuous rating Input	840W
Wheel diameter	115 mm (4-1/2")
No load speed	11,000 min ⁻¹
Dimensions (L x W x H)	273 x 129 x 106 mm (10-3/4 x 5-1/8 x 4-3/16")
Net weight	1.7 - 2.2 kg (3.7 - 4.9 lbs.)

9558HP

Continuous rating Input	840W
Wheel diameter	125 mm (5")
No load speed	11,000 min ⁻¹
Dimensions (L x W x H)	273 x 139 x 106 mm (10-3/4 x 5-1/2 x 4-3/16")
Net weight	1.8 - 3 kg (3.9 - 6.7 lbs.)

Angle Grinder



GA4031

Continuous rating Input	720W
Wheel diameter	100 mm (4")
No load speed	11,000 min ⁻¹
Dimensions (L x W x H)	259 x 118 x 104 mm (10-1/4 x 4-5/8 x 4-1/8")
Net weight	1.71 - 2 kg (3.77 - 4.41 lbs.)

GA4032

Continuous rating Input	720W
Wheel diameter	100 mm (4")
No load speed	9,000 min ⁻¹
Dimensions (L x W x H)	259 x 118 x 104 mm (10-1/4 x 4-5/8 x 4-1/8")
Net weight	1.67 - 1.96 kg (3.68 - 4.32 lbs.)

Angle Grinder



GA4030R

Continuous rating Input	720W
Wheel diameter	100 mm (4")
No load speed	11,000 min ⁻¹
Dimensions (L x W x H)	266 x 118 x 102 mm (10-1/2 x 4-5/8 x 4")
Net weight	1.72 - 2.01 kg (3.79 - 4.43 lbs.)

GA4530R

Continuous rating Input	720W
Wheel diameter	115 mm (4-1/2")
No load speed	11,000 min ⁻¹
Dimensions (L x W x H)	266 x 130 x 108 mm (10-1/2 x 5-1/2 x 4-1/4")
Net weight	1.88 - 2.22 kg (4.14 - 4.89 lbs.)

GA5030R

Continuous rating Input	720W
Wheel diameter	125 mm (5")
No load speed	11,000 min ⁻¹
Dimensions (L x W x H)	266 x 140 x 108 mm (10-1/2 x 5-1/2 x 4-1/4")
Net weight	1.91 - 3.06 kg (4.21 - 6.75 lbs.)

Grinding/Sanding/Polishing

Angle Grinder



	GA4030	GA4530	GA5030
Continuous rating Input	720W	720W	720W
Wheel diameter	100 mm (4")	115 mm (4-1/2")	125 mm (5")
No load speed	11,000 min ⁻¹	11,000 min ⁻¹	11,000 min ⁻¹
Dimensions (L x W x H)	266 x 117 x 95 mm (10-1/2 x 4-5/8 x 3-3/4")	266 x 128 x 103 mm (10-1/2 x 5 x 4-1/16")	266 x 138 x 103 mm (10-1/2 x 5-7/16 x 4-1/16")
Net weight	1.73 - 2.02 kg (3.81 - 4.45 lbs.)	1.89 - 2.23 kg (4.17 - 4.91 lbs.)	1.92 - 3.07 kg (4.23 - 6.77 lbs.)



Angle Grinder



	GA4034	GA4534	GA5034
Continuous rating Input	720W	720W	720W
Wheel diameter	100 mm (4")	115 mm (4-1/2")	125 mm (5")
No load speed	11,000 min ⁻¹	11,000 min ⁻¹	11,000 min ⁻¹
Dimensions (L x W x H)	265 x 118 x 95 mm (10-3/8 x 4-5/8 x 3-3/4")	265 x 128 x 103 mm (10-3/8 x 5 x 4-1/16")	265 x 139 x 103 mm (10-3/8 x 5-1/2 x 4-1/16")
Net weight	1.77 - 2.06 kg (3.9 - 4.54 lbs.)	1.98 - 2.31 kg (4.37 - 5.09 lbs.)	2 - 3.15 kg (4.41 - 6.94 lbs.)



Angle Grinder



	9553HN	9554HN	9555HN
Continuous rating Input	710W	710W	710W
Wheel diameter	100 mm (4")	115 mm (4-1/2")	125 mm (5")
No load speed	11,000 min ⁻¹	10,000 min ⁻¹	10,000 min ⁻¹
Dimensions (L x W x H)	258 x 118 x 97 mm (10-1/8 x 4-5/8 x 3-13/16")	258 x 129 x 106 mm (10-1/8 x 5-1/8 x 4-3/16")	258 x 139 x 106 mm (10-1/8 x 5-1/2 x 4-3/16")
Net weight	1.5 - 1.8 kg (3.2 - 4.1 lbs.)	1.6 - 2 kg (3.5 - 4.4 lbs.)	1.6 - 2.9 kg (3.5 - 6.3 lbs.)



Angle Grinder



	9553HB
Continuous rating Input	710W
Wheel diameter	100 mm (4")
No load speed	11,000 min ⁻¹
Dimensions (L x W x H)	258 x 118 x 97 mm (10-1/8 x 4-5/8 x 3-13/16")
Net weight	1.5 - 1.9 kg (3.3 - 4.1 lbs.)



Angle Grinder

9500NB: Double Insulation



	9500NB	N9500N
Continuous rating Input	570W	570W
Wheel diameter	100 mm (4")	100 mm (4")
No load speed	12,000 min ⁻¹	12,000 min ⁻¹
Overall length	253 mm (10")	245 mm (9-5/8")
Net weight	1.9 kg (3.5 - 4.3 lbs.)	1.6 - 1.9 kg (3.5 - 4.2 lbs.)

▼ 9500NB



N9500N: Disc Grinder



Grinding/Sanding/Polishing

Angle Grinder



AFT



	GA7070	GA9070
Continuous rating Input	2,800W	2,800W
Wheel diameter	180 mm (7")	230 mm (9")
No load speed	8,500 min ⁻¹	6,600 min ⁻¹
Dimensions (L x W x H)	506 x 200 x 146 mm (20 x 7-7/8 x 5-3/4")	506 x 250 x 146 mm (20 x 9-7/8 x 5-3/4")
Net weight	6.1 - 6.6 kg (13.5 - 14.6 lbs.)	6.3 - 8.5 kg (13.9 - 18.7 lbs.)

Angle Grinder



AFT



	GA7071	GA9071
Continuous rating Input	2,800W	2,800W
Wheel diameter	180 mm (7")	230 mm (9")
No load speed	8,500 min ⁻¹	6,600 min ⁻¹
Dimensions (L x W x H)	506 x 200 x 146 mm (20 x 7-7/8 x 5-3/4")	506 x 250 x 146 mm (20 x 9-7/8 x 5-3/4")
Net weight	6.2 - 6.7 kg (13.7 - 14.8 lbs.)	6.4 - 8.5 kg (14.1 - 18.7 lbs.)

Angle Grinder



	GA7080	GA9080
Continuous rating Input	2,700W	2,700W
Wheel diameter	180 mm (7")	230 mm (9")
No load speed	8,500 min ⁻¹	6,600 min ⁻¹
Dimensions (L x W x H)	509 x 200 x 144 mm (20 x 7-7/8 x 5-5/8")	509 x 250 x 144 mm (20 x 9-7/8 x 5-5/8")
Net weight	6.3 - 6.8 kg (13.9 - 15.0 lbs.)	6.5 - 8.6 kg (14.3 - 19.0 lbs.)

Angle Grinder



	GA7081	GA9081
Continuous rating Input	2,700W	2,700W
Wheel diameter	180 mm (7")	230 mm (9")
No load speed	8,500 min ⁻¹	6,600 min ⁻¹
Dimensions (L x W x H)	461 x 200 x 144 mm (18-1/8 x 7-7/8 x 5-5/8")	461 x 250 x 144 mm (18-1/8 x 9-7/8 x 5-5/8")
Net weight	6.1 - 6.6 kg (13.4 - 14.6 lbs.)	6.3 - 8.4 kg (13.9 - 18.5 lbs.)

Angle Grinder



	GA7082	GA9082
Continuous rating Input	2,700W	2,700W
Wheel diameter	180 mm (7")	230 mm (9")
No load speed	8,500 min ⁻¹	6,600 min ⁻¹
Dimensions (L x W x H)	461 x 200 x 144 mm (18-1/8 x 7-7/8 x 5-5/8")	461 x 250 x 144 mm (18-1/8 x 9-7/8 x 5-5/8")
Net weight	6.0 - 6.5 kg (13.2 - 14.3 lbs.)	6.2 - 8.3 kg (13.7 - 18.3 lbs.)

Angle Grinder



	GA9040R
Continuous rating Input	2,600W
Wheel diameter	230 mm (9")
No load speed	6,600 min ⁻¹
Dimensions (L x W x H)	503 x 250 x 140 mm (19-3/4 x 9-7/8 x 5-1/2")
Net weight	6.69 - 8.98 kg (14.8 - 19.6 lbs.)

Angle Grinder



	GA7040S	GA9040S
Continuous rating Input	2,600W	2,600W
Wheel diameter	180 mm (7")	230 mm (9")
No load speed	8,500 min ⁻¹	6,600 min ⁻¹
Dimensions (L x W x H)	511 x 200 x 140 mm (20-1/8 x 7-7/8 x 5-1/2")	503 x 250 x 140 mm (19-3/4 x 9-7/8 x 5-1/2")
Net weight	6.45 - 6.95 kg (14.2 - 15.3 lbs.)	6.65 - 8.94 kg (14.7 - 19.7 lbs.)

Grinding/Sanding/Polishing

Angle Grinder



	GA7030R	GA9030R
Continuous rating Input	2,400W	2,400W
Wheel diameter	180 mm (7")	230 mm (9")
No load speed	8,500 min ⁻¹	6,600 min ⁻¹
Dimensions (L x W x H)	503 x 200 x 140 mm (19-3/4 x 7-7/8 x 5-1/2")	503 x 250 x 140 mm (19-3/4 x 9-7/8 x 5-1/2")
Net weight	6.17 - 6.67 kg (13.6 - 14.7 lbs.)	6.36 - 8.65 kg (14 - 19.1 lbs.)



Angle Grinder



	GA9030S
Continuous rating Input	2,400W
Wheel diameter	230 mm (9")
No load speed	6,600 min ⁻¹
Dimensions (L x W x H)	503 x 250 x 140 mm (19-3/4 x 9-7/8 x 5-1/2")
Net weight	6.27 - 8.56 kg (13.8 - 18.9 lbs.)



Angle Grinder



	GA7030	GA9030
Continuous rating Input	2,400W	2,400W
Wheel diameter	180 mm (7")	230 mm (9")
No load speed	8,500 min ⁻¹	6,600 min ⁻¹
Dimensions (L x W x H)	511 x 200 x 140 mm (20-1/8 x 7-7/8 x 5-1/2")	503 x 250 x 140 mm (19-3/4 x 9-7/8 x 5-1/2")
Net weight	6.06 - 6.56 kg (13.36 - 14.46 lbs.)	6.26 - 8.55 kg (13.8 - 18.9 lbs.)



Angle Grinder

AC/DC Trigger Switch



	GA7031	GA9031
Continuous rating Input	2,400W	2,400W
Wheel diameter	180 mm (7")	230 mm (9")
No load speed	8,500 min ⁻¹	6,600 min ⁻¹
Dimensions (L x W x H)	504 x 200 x 140 mm (19-7/8 x 7-7/8 x 5-1/2")	504 x 250 x 140 mm (19-7/8 x 9-7/8 x 5-1/2")
Net weight	5.93 - 6.43 kg (13.1 - 14.2 lbs.)	6.13 - 8.42 kg (13.5 - 18.6 lbs.)



Angle Grinder



	GA7061R	GA9061R
Continuous rating Input	2,200W	2,200W
Wheel diameter	180 mm (7")	230 mm (9")
No load speed	8,500 min ⁻¹	6,600 min ⁻¹
Dimensions (L x W x H)	450 x 200 x 145 mm (17-3/4 x 7-7/8 x 5-3/4")	450 x 250 x 145 mm (17-3/4 x 9-7/8 x 5-3/4")
Net weight	5.57 - 6.08 kg (12.3 - 13.4 lbs.)	5.68 - 8.04 kg (12.5 - 17.7 lbs.)

SJS™



Angle Grinder



	GA7061	GA9061
Continuous rating Input	2,200W	2,200W
Wheel diameter	180 mm (7")	230 mm (9")
No load speed	8,500 min ⁻¹	6,600 min ⁻¹
Dimensions (L x W x H)	450 x 200 x 145 mm (17-3/4 x 7-7/8 x 5-3/4")	450 x 250 x 145 mm (17-3/4 x 9-7/8 x 5-3/4")
Net weight	5.53 - 6.04 kg (12.2 - 13.3 lbs.)	5.63 - 7.99 kg (12.4 - 17.6 lbs.)

SJS™



Angle Grinder



	GA9062
Continuous rating Input	2,200W
Wheel diameter	230 mm (9")
No load speed	6,600 min ⁻¹
Dimensions (L x W x H)	450 x 250 x 144 mm (17-3/4 x 9-7/8 x 5-5/8")
Net weight	5.61 - 7.97 kg (12.4 - 17.6 lbs.)



Grinding/Sanding/Polishing

Angle Grinder



	GA7060R	GA9060R
Continuous rating Input	2,200W	2,200W
Wheel diameter	180 mm (7")	230 mm (9")
No load speed	8,500 min ⁻¹	6,600 min ⁻¹
Dimensions (L x W x H)	450 x 200 x 144 mm (17-3/4 x 7-7/8 x 5-5/8")	450 x 250 x 144 mm (17-3/4 x 9-7/8 x 5-5/8")
Net weight	5.42 - 5.93 kg (12 - 13.1 lbs.)	5.52 - 7.88 kg (12.8 - 17.4 lbs.)



Angle Grinder



	GA7064	GA7060	GA9060
Continuous rating Input	2,200W	2,200W	2,200W
Wheel diameter	180 mm (7")	180 mm (7")	230 mm (9")
No load speed	6,600 min ⁻¹	8,500 min ⁻¹	6,600 min ⁻¹
Dimensions (L x W x H)	450 x 200 x 144 mm (17-3/4 x 7-7/8 x 5-5/8")	450 x 200 x 144 mm (17-3/4 x 7-7/8 x 5-5/8")	450 x 250 x 144 mm (17-3/4 x 9-7/8 x 5-5/8")
Net weight	5.34 - 5.85 kg (11.8 - 12.9 lbs.)	5.38 - 5.89 kg (11.9 - 13 lbs.)	5.5 - 7.86 kg (12.1 - 17.3 lbs.)



Angle Grinder

new



	GA7090	GA9090
Continuous rating input	2,200 W	2,200 W
Wheel diameter	180 mm (7")	230 mm (9")
No load speed	8,500 min ⁻¹	6,600 min ⁻¹
Cutting depth	69 mm (2-3/4")	69 mm (2-3/4")
Dimensions (L x W x H)	438 x 200 x 144 mm (17-1/4 x 7-7/8 x 5-5/8")	438 x 250 x 144 mm (17-1/4 x 9-7/8 x 5-5/8")
Net weight	5.1 - 7.3 kg (11.2 - 16.1 lbs.)	5.3 - 7.4 kg (11.7 - 16.3 lbs.)



Angle Grinder



	GA7020R	GA9020R
Continuous rating Input	2,200W	2,200W
Wheel diameter	180 mm (7")	230 mm (9")
No load speed	8,500 min ⁻¹	6,600 min ⁻¹
Dimensions (L x W x H)	473 x 200 x 140 mm (18-5/8 x 7-7/8 x 5-1/2")	473 x 250 x 140 mm (18-5/8 x 9-7/8 x 5-1/2")
Net weight	5.66 - 6.16 kg (12.48 - 13.58 lbs.)	5.8 - 8.09 kg (12.8 - 17.8 lbs.)



Angle Grinder



	GA7020	GA9020
Continuous rating Input	2,200W	2,200W
Wheel diameter	180 mm (7")	230 mm (9")
No load speed	8,500 min ⁻¹	6,600 min ⁻¹
Dimensions (L x W x H)	473 x 200 x 140 mm (18-5/8 x 7-7/8 x 5-1/2")	473 x 249 x 140 mm (18-5/8 x 9-3/4 x 5-1/2")
Net weight	5.56 - 6.06 kg (12.26 - 13.36 lbs.)	5.76 - 8.05 kg (12.7 - 17.8 lbs.)



Angle Grinder



	GA7020S	GA9020S
Continuous rating Input	2,200W	2,200W
Wheel diameter	180 mm (7")	230 mm (9")
No load speed	8,500 min ⁻¹	6,600 min ⁻¹
Dimensions (L x W x H)	473 x 200 x 140 mm (18-5/8 x 7-7/8 x 5-1/2")	473 x 249 x 140 mm (18-5/8 x 9-3/4 x 5-1/2")
Net weight	5.69 - 6.19 kg (12.55 - 13.65 lbs.)	5.85 - 8.14 kg (12.9 - 18 lbs.)



Angle Grinder



	GA7050R	GA9050R
Continuous rating Input	2,000W	2,000W
Wheel diameter	180 mm (7")	230 mm (9")
No load speed	8,500 min ⁻¹	6,600 min ⁻¹
Dimensions (L x W x H)	455 x 200 x 132 mm (17-7/8 x 7-7/8 x 5-3/16")	455 x 250 x 132 mm (17-7/8 x 9-7/8 x 5-3/16")
Net weight	4.66 - 5.18 kg (10.3 - 11.4 lbs.)	4.82 - 7.12 kg (10.6 - 15.7 lbs.)



Grinding/Sanding/Polishing

Angle Grinder



	GA7050	GA9050
Continuous rating Input	2,000W	2,000W
Wheel diameter	180 mm (7")	230 mm (9")
No load speed	8,500 min ⁻¹	6,600 min ⁻¹
Dimensions (L x W x H)	432 x 200 x 132 mm (17 x 7-7/8 x 5-3/16")	432 x 250 x 132 mm (17 x 9-7/8 x 5-3/16")
Net weight	3.98 - 5 kg (8.8 - 11 lbs.)	4.64 - 6.94 kg (10.2 - 15.3 lbs.)



Angle Grinder



	GA7012C	GA9012C
Continuous rating Input	1,800W	1,800W
Wheel diameter	180 mm (7")	230 mm (9")
No load speed	8,400 min ⁻¹	6,000 min ⁻¹
Dimensions (L x W x H)	453 x 200 x 137 mm (17-7/8 x 7-7/8 x 5-3/8")	453 x 250 x 137 mm (17-7/8 x 9-7/8 x 5-3/8")
Net weight	4 - 4.5 kg (8.82 - 9.92 lbs.)	4.37 - 6.66 kg (9.6 - 14.7 lbs.)



Angle Grinder



	GA7010C	GA9010C
Continuous rating Input	1,800W	1,800W
Wheel diameter	180 mm (7")	230 mm (9")
No load speed	8,400 min ⁻¹	6,000 min ⁻¹
Dimensions (L x W x H)	453 x 200 x 137 mm (17-7/8 x 7-7/8 x 5-3/8")	453 x 250 x 137 mm (17-7/8 x 9-7/8 x 5-3/8")
Net weight	4.2 - 4.7 kg (9.26 - 10.36 lbs.)	4.36 - 6.65 kg (9.6 - 14.7 lbs.)



Comparison List

Model No.			No load speed (rpm)	Switch	AWS	BL motor	AFT	ADT	XPT	Brake	Anti-restart function	X-Lock
40Vmax Cordless Angle Grinder												
100mm	115mm	125mm										
GA003G	GA004G	GA005G	8,500	Slide	-	●	●	-	●	●	●	-
GA006G	GA007G	GA008G	8,500	Slide	-	●	●	-	●	-	●	-
GA011G	GA012G	GA013G	8,500	Paddle	-	●	●	-	●	●	●	-
GA014G	GA015G	GA016G	8,500	Paddle	-	●	●	-	●	-	●	-
GA021G	GA022G	GA023G	3,000 - 8,500	Slide	●	●	●	-	●	●	●	-
GA024G	GA025G	GA026G	3,000 - 8,500	Slide	●	●	●	-	●	-	●	-
GA027G	GA028G	GA029G	3,000 - 8,500	Paddle	●	●	●	-	●	●	●	-
GA030G	GA031G	GA032G	3,000 - 8,500	Paddle	●	●	●	-	●	-	●	-
GA039G	GA040G	GA041G	3,000 - 8,500	Slide	●	●	●	-	●	●	●	●
GA042G	GA043G	GA044G	3,000 - 8,500	Paddle	●	●	●	-	●	●	●	●
GA045G	GA046G	GA047G	8,500	Paddle	-	●	●	-	●	●	●	●
GA048G	GA049G	GA050G	11,000	Paddle	-	●	●	-	●	●	●	-
150mm	180mm	230mm										
GA035G	-	-	8,500	Slide	-	●	●	-	●	●	●	-
GA036G	-	-	8,500	Paddle	-	●	●	-	●	●	●	-
-	GA037G	-	7,800	Large Trigger	●	●	●	-	●	●	●	-
-	-	GA038G	6,600	Large Trigger	●	●	●	-	●	●	●	-
GA051G	-	-	9,000	Paddle	-	●	●	-	●	●	●	-
18V x2 Cordless Angle Grinder												
180mm	230mm											
DGA700	-	-	7,800	Large Trigger	-	●	●	●	●	●	●	-
DGA701	-	-	7,800	Large Trigger	●	●	●	●	●	●	●	-
-	DGA900	-	6,000	Large Trigger	-	●	●	●	●	●	●	-
-	DGA901	-	6,000	Large Trigger	●	●	●	●	●	●	●	-
18V Cordless Angle Grinder												
100mm	115mm	125mm										
DGA414	-	DGA514	3,000 - 8,500	Slide	●	●	●	●	●	●	●	-
DGA413	DGA463	DGA513	3,000 - 8,500	Slide	-	●	●	●	●	●	●	-
DGA412	-	DGA512	3,000 - 8,500	Slide	●	●	●	●	●	-	●	-
DGA411	DGA461	DGA511	3,000 - 8,500	Slide	-	●	●	●	●	-	●	-
DGA406	DGA456	DGA506	8,500	Slide	-	●	●	●	●	●	●	-
DGA404	DGA454	DGA504	8,500	Slide	-	●	●	●	●	-	●	-
-	-	DGA521	8,500	Slide	-	●	●	●	●	-	●	●
DGA402	DGA452	-	11,000	Slide	-	-	-	-	-	-	●	-
DGA418	-	DGA518	3,000 - 8,500	Paddle	●	●	●	●	●	●	●	-
DGA417	DGA467	DGA517	3,000 - 8,500	Paddle	-	●	●	●	●	●	●	-
DGA419	DGA469	DGA519	3,000 - 8,500	Paddle	-	●	●	●	●	●	●	●
DGA408	DGA458	DGA508	8,500	Paddle	-	●	●	●	●	●	●	-
DGA405	DGA455	DGA505	8,500	Paddle	-	●	●	●	●	-	●	-
-	-	DGA520	8,500	Paddle	-	●	●	●	●	●	●	●

Comparison List

Model No.				Continuous rating Input (W)	Switch	SJS / SJS2	Anti-restart function	Variable Speed	Constant Speed	AFT	Brake	Soft Start	X-Lock
Angle Grinder													
100mm	115mm	125mm	150mm										
-	GA4590	GA5090	-	1,900	Slide	SJS2	●	●	●	●	-	●	-
-	GA4591	GA5091	-	1,900	Slide	SJS2	●	●	●	●	●	●	-
-	GA4592	GA5092	-	1,900	Slide	SJS2	●	-	●	●	-	●	-
-	GA4593	GA5093	-	1,900	Paddle	SJS2	●	●	●	●	●	●	-
-	GA4594	GA5094	-	1,900	Paddle	SJS2	●	-	●	●	●	●	-
-	GA4595	GA5095	-	1,900	Paddle	SJS2	●	-	●	●	-	●	-
-	-	GA5021C	GA6021C	1,450	Large trigger	SJS	●	-	●	-	-	●	-
-	-	GA5020C	GA6020C	1,450	Finger trigger	SJS	●	-	●	-	-	●	-
-	-	GA5041C	-	1,400	Slide	SJS2	●	●	●	-	●	●	-
GA4040C	GA4540C	GA5040C	GA6040C	1,400	Slide	SJS2	●	●	●	-	-	●	-
-	GA4542C	GA5042C	GA6042C	1,400	Slide	SJS2	-	●	●	-	-	●	-
-	-	9565CVR	-	1,400	Slide	SJS	●	●	●	-	-	●	-
-	9564CV	9565CV	9566CV	1,400	Slide	SJS	-	●	●	-	-	●	-
-	-	9565CR	-	1,400	Slide	SJS	●	-	●	-	-	●	-
-	-	9565C	-	1,400	Slide	SJS	-	-	●	-	-	●	-
-	9564PCV	9565PCV	9566PCV	1,400	Paddle	SJS	-	●	●	-	-	●	-
-	9564PC	9565PC	9566PC	1,400	Paddle	SJS	-	-	●	-	-	●	-
-	-	GA5080 / GA5080R	-	1,400	Slide	SJS	●	-	●	-	-	●	●
GA4050	GA4550 / GA4552	GA5050 / GA5052	-	1,300	Paddle	-	-	-	-	-	-	-	-
GA4050R	GA4550R / GA4552R	GA5050R / GA5052R	-	1,300	Paddle	-	●	-	-	-	-	●	-
GA4051R	GA4551R / GA4553R	GA5051R / GA5053R	-	1,300	Paddle	-	●	-	-	-	-	●	-
-	GA4540R	GA5040R	GA6040R	1,100	Slide	SJS2	●	-	-	-	-	●	-
GA4040	GA4540	GA5040	GA6040	1,100	Slide	SJS2	-	-	-	-	-	-	-
-	-	9565HR	-	1,100	Slide	SJS	●	-	-	-	-	●	-
-	9564P	-	-	1,100	Paddle	SJS	-	-	-	-	-	-	-
-	-	GA5021	GA6021	1,050	Large trigger	SJS	-	-	-	-	-	-	-
-	-	GA5011	-	1,050	Large trigger	-	-	-	-	-	-	-	-
-	-	GA5010 / GA5020	GA6010 / GA6020	1,050	Finger trigger	- / SJS	-	-	-	-	-	-	-
GA4100	GA4600	GA5100	-	850	Slide	-	●	●	●	-	-	●	-
GA4570	-	-	-	840	Slide	-	-	-	-	-	-	-	●
9556HN	9557HN	9558HN	-	840	Slide	-	-	-	-	-	-	-	-
-	9557NBR / 9557HNR	9558NBR / 9558HNR	-	840	Slide	-	●	-	-	-	-	●	-
9556HP	9557HP	9558HP	-	840	Paddle	-	-	-	-	-	-	-	-
9556HB	-	-	-	840	Toggle	-	-	-	-	-	-	-	-
GA4031 / GA4032	-	-	-	720	Toggle	-	-	-	-	-	-	-	-
GA4030R	GA4530R	GA5030R	-	720	Slide	-	●	-	-	-	-	●	-
GA4030	GA4530	GA5030	-	720	Slide	-	-	-	-	-	-	-	-
GA4034	GA4534	GA5034	-	720	Paddle	-	-	-	-	-	-	-	-
9553HN	9554HN	9555HN	-	710	Slide	-	-	-	-	-	-	-	-
9553HB	-	-	-	710	Toggle	-	-	-	-	-	-	-	-
9500NB / N9500N	-	-	-	570	Toggle	-	-	-	-	-	-	-	-



Comparison List

Model No.		Continuous rating Input (W)	Switch	SJS / SJS2	Anti-restart function	Constant Speed	AFT	Brake	Torque Limiter	Soft Start	X-Lock
180mm	230mm										
GA7070	GA9070	2,800W	Large trigger	-	●	●	●	●	●	●	-
GA7071	GA9071	2,800W	Large trigger	-	●	●	●	●	●	●	-
GA7080 / GA7081	GA9080 / GA9081	2,700W	Large trigger	-	●	-	-	-	●	●	-
GA7082	GA9082	2,700W	Large trigger	-	-	-	-	-	●	-	-
GA7040S	GA9040S	2,600W	Large trigger	-	-	-	-	-	●	●	-
-	GA9040	2,600W	Large trigger	-	-	-	-	-	●	-	-
GA7030R	GA9030R	2,400W	Large trigger	-	●	-	-	-	●	●	-
- / GA7030	GA9030S / GA9030	2,400W	Large trigger	-	-	-	-	-	●	● / -	-
GA7031	GA9031	2,400W	AC/DC trigger	-	-	-	-	-	●	-	-
GA7061R	GA9061R	2,200W	Large trigger	SJS2	●	-	-	-	-	●	-
GA7061	GA9061	2,200W	Large trigger	SJS2	-	-	-	-	-	-	-
GA7060R	GA9060R / GA9062R	2,200W	Large trigger	-	●	-	-	-	-	●	-
GA7060 / GA7064	GA9060	2,200W	Large trigger	-	-	-	-	-	-	-	-
GA7090	GA9090	2,200W	Large trigger	-	-	-	-	-	-	-	-
GA7020R	GA9020R	2,200W	Large trigger	-	●	-	-	-	-	●	-
GA7020	GA9020	2,200W	Large trigger	-	-	-	-	-	-	-	-
GA7020S	GA9020S	2,200W	Large trigger	-	-	-	-	-	-	●	-
GA7050 / GA7050R	GA9050 / GA9050R	2,000W	Large trigger	-	- / ●	-	-	-	-	- / ●	-
GA7012C	GA9012C	1,800W	Large trigger	-	●	●	-	-	-	●	-
GA7010C	GA9010C	1,800W	Large trigger	-	-	●	-	-	-	●	-

Grinding / Sanding / Polishing



Grinding/Sanding/Polishing

**Angle Sander
SA7000C**

Continuous rating Input	1,600W
Abrasive disc size	180 mm (7")
No load speed	1,500 - 4,000 min ⁻¹
Dimensions (L x W x H)	453 x 170 x 136 mm (17-7/8 x 6-11/16 x 5-3/8")
Net weight	3.5 - 3.6 kg (7.7 - 7.9 lbs.)

**Angle Sander
SA5040C**

Continuous rating Input	1,400W
Wheel diameter	125 mm (5")
No load speed	2,000 - 7,800 min ⁻¹
Dimensions (L x W x H)	315 x 115 x 121 mm (12-3/8 x 4-1/2 x 4-3/4")
Net weight	2.5 - 3.7 kg (5.5 - 8.2 lbs.)

**Angle Sander
SA7000**

Continuous rating Input	1,400W
Abrasive disc size	180 mm (7")
No load speed	5,000 min ⁻¹
Dimensions (L x W x H)	453 x 170 x 136 mm (17-7/8 x 6-11/16 x 5-3/8")
Net weight	3.5 - 3.6 kg (7.7 - 7.9 lbs.)

**Angle Sander
PK5011C**

Continuous rating Input	1,600W
Wheel diameter	125 mm (5")
No load speed	2,000 - 5,500 min ⁻¹
Dimensions (L x W x H)	468 x 159 x 155 mm (18-1/2 x 6-1/4 x 6-1/8")
Net weight	4.3 - 4.4 kg (9.5 - 9.7 lbs.)

**Disc Sander
GV7000C**

Continuous rating Input	900W
Abrasive disc size	180 mm (7")
Capacity	Pad: 180 mm (7")
No load speed	2,500 - 4,700 min ⁻¹
Overall length	210 mm (8-1/4")
Net weight	2.1 kg (4.6 lbs.)

**Disc Sander
GV7000**

Continuous rating Input	550W
Abrasive disc size	180 mm (7")
Capacity	Pad: 180 mm (7")
No load speed	4,700 min ⁻¹
Overall length	210 mm (8-1/4")
Net weight	2.1 kg (4.7 lbs.)

**Disc Sander
GV6010**

Continuous rating Input	440W
Abrasive disc size	150 mm (6")
Capacity	Pad: 120 mm (4-3/4")
No load speed	4,500 min ⁻¹
Dimensions (L x W x H)	200 x 74 x 181 mm (7-7/8 x 2-15/16 x 7-1/8")
Net weight	1.2 kg (2.6 lbs.)

**Disc Sander
GV5010**

Continuous rating Input	440W
Abrasive disc size	125 mm (5")
Capacity	Pad: 120 mm (4-3/4")
No load speed	4,500 min ⁻¹
Dimensions (L x W x H)	200 x 74 x 181 mm (7-7/8 x 2-15/16 x 7-1/8")
Net weight	1.2 kg (2.6 lbs.)

**Cordless Polisher
PV001G**

40V max

Brush pad capacity	180 mm (7")
Pad diameter	165 mm (6-1/2")
No load speed	by Trigger: 0 - 2,200 min ⁻¹ by Dial: 600 - 2,200 min ⁻¹
Dimensions (L x W x H)	w/ BL4080F: 550 x 196 x 195 mm (21-5/8 x 7-3/4 x 7-5/8")
Net weight	3.0 - 4.4 kg (6.6 - 9.7 lbs.)



Grinding/Sanding/Polishing

Polisher 9237CB

Continuous rating Input	1,200W
Capacity	Wool bonnet: 180 mm (7") Curved blade design: 180 mm (7")
No load speed	0 - 3,200 min ⁻¹
Dimensions (L x W x H)	431 x 198 x 187 mm (17 x 7-3/4 x 7-3/8")
Net weight	3.2 - 3.4 kg (7 - 7.5 lbs.)



Polisher 9237C

Continuous rating Input	1,200W
Capacity	Wool bonnet: 180 mm (7") Curved blade design: 180 mm (7")
No load speed	0 - 3,200 min ⁻¹
Dimensions (L x W x H)	431 x 198 x 187 mm (17 x 7-3/4 x 7-3/8")
Net weight	3.4 kg (7.5 lbs.)



Polisher PV7000C

Continuous rating Input	900W
Capacity	Pad: 180 mm (7") Wool bonnet: 180 mm (7")
No load speed	600 - 2,100 min ⁻¹
Overall length	210 mm (8-1/4")
Net weight	2.1 kg (4.6 lbs.)



Polisher PV7001C

Continuous rating Input	900W
Capacity	Pad: 180 mm (7") Wool bonnet: 180 mm (7")
No load speed	600 - 2,000 min ⁻¹
Overall length	210 mm (8-1/4")
Net weight	2.1 - 2.2 kg (4.6 - 4.9 lbs.)



Cordless Sander Polisher DPV300

18V



Pad / disc diameter	Twist-on / Twist-off style: 50 mm (2") Hook & Loop Style: 80 mm (3-1/8")
Backing pad diameter	Twist-on / Twist-off style: 46 mm (1-13/16") Hook & Loop style: 75 mm (2-15/16")
Brush pad capacity	80 mm (3-1/8")
Disc paper diameter	50 mm (2")
No load speed	Polishing: 0 - 2,800 min ⁻¹ Sanding: 0 - 9,500 min ⁻¹
Head length	127 mm (5")
Dimensions (L x W x H)	w/ BL1830B / BL1840B / BL1850B / BL1860B: 160 x 79 x 256 mm (6-5/16 x 3-1/8 x 10-1/8")
Net weight	1.3 - 1.6 kg (2.9 - 3.5 lbs.)

LXI MOTOR BL XPT



Cordless Sander Polisher PV301D

12V max



Pad / disc diameter	Twist-on / Twist-off style: 50 mm (2") Hook & Loop Style: 80 mm (3-1/8")
Backing pad diameter	Twist-on / Twist-off style: 46 mm (1-13/16") Hook & Loop style: 75 mm (2-15/16")
Brush pad capacity	80 mm (3-1/8")
Disc paper diameter	50 mm (2")
No load speed	Polishing: 0 - 2,800 min ⁻¹ Sanding: 0 - 9,500 min ⁻¹
Head length	127 mm (5")
Dimensions (L x W x H)	w/ BL1041B: 139 x 67 x 249 mm (5-1/2 x 2-5/8 x 9-3/4")
Net weight	1.1 - 1.2 kg (2.4 - 2.6 lbs.)

CXI MOTOR BL XPT



Stone Polisher PW5000C



Continuous rating Input	900W
Wheel diameter	100 - 125 mm (4 - 5")
Capacity	Pad: 100 - 125 mm (4 - 5")
No load speed	2,000 - 4,000 min ⁻¹
Overall length	313 mm (12-3/8")
Net weight	2.3 - 2.6 kg (5.1 - 5.7 lbs.)



Stone Polisher PW5001C



Continuous rating Input	900W
Wheel diameter	100 - 125 mm (4 - 5")
Capacity	Pad: 100 - 125 mm (4 - 5")
No load speed	2,000 - 4,000 min ⁻¹
Overall length	359 mm (14-1/8")
Net weight	2.3 - 2.6 kg (5.1 - 5.7 lbs.)



Grinding/Sanding/Polishing

**Cordless Die Grinder
DGD800**

18V

Collet size	3 / 6 / 8 mm (1/8 / 1/4")
Wheel diameter	36 mm (1-7/16")
No load speed	26,000 min ⁻¹
Mandrel (shank) length	46 mm
Dimensions (L x W x H)	402 x 82 x 118 mm (15-3/4 x 3-1/4 x 4-5/8")
Net weight	1.7 - 2.2 kg (3.8 - 4.9 lbs.)



LXT

**Die Grinder
GD0810C**

Continuous rating Input	750W
Collet size	3 / 6 / 8 mm (1/8 / 1/4")
Wheel diameter	50 mm (2")
No load speed	7,000 min ⁻¹
Overall length	371 mm (14-5/8")
Net weight	1.9 kg (4.2 lbs.)

SUPER JOINT SYSTEM
SJS**Die Grinder
GD0800C**

Continuous rating Input	750W
Collet size	3 / 6 / 8 mm (1/8 / 1/4")
Wheel diameter	25 mm (1")
No load speed	28,000 min ⁻¹
Dimensions (L x W x H)	371 x 75 x 75 mm (14-5/8 x 2-15/16 x 2-15/16")
Net weight	1.88 kg (4.14 lbs.)

SUPER JOINT SYSTEM
SJS**Die Grinder
GD0800**

Continuous rating Input	500W
Collet size	3 / 6 / 8 mm (1/8 / 1/4")
Wheel diameter	25 mm (1")
No load speed	28,000 min ⁻¹
Dimensions (L x W x H)	371 x 75 x 75 mm (14-5/8 x 2-15/16 x 2-15/16")
Net weight	1.78 kg (3.92 lbs.)

SUPER JOINT SYSTEM
SJS**Die Grinder
GD0602**

Continuous rating Input	400W
Collet size	3 / 6 / 8 mm (1/8 / 1/4")
Wheel diameter	38 mm (1-1/2")
No load speed	25,000 min ⁻¹
Dimensions (L x W x H)	264 x 82 x 82 mm (10-3/8 x 3-1/4 x 3-1/4")
Net weight	1.41 - 1.57 kg (3.11 - 3.46 lbs.)

**Cordless Die Grinder
DGD801**

18V

Collet size	3 / 6 / 8 mm (1/8 / 1/4")
Wheel diameter	36 mm (1-7/16")
No load speed	26,000 min ⁻¹
Mandrel (shank) length	46 mm
Dimensions (L x W x H)	307 x 82 x 118 mm (12-1/8 x 3-1/4 x 4-5/8")
Net weight	1.5 - 2 kg (3.3 - 4.3 lbs.)



LXT

**Die Grinder
GD0811C**

Continuous rating Input	750W
Collet size	3 / 6 / 8 mm (1/8 / 1/4")
Wheel diameter	50 mm (2")
No load speed	7,000 min ⁻¹
Dimensions (L x W x H)	390 x 75 x 88 mm (15-3/8 x 2-15/16 x 3-1/2")
Net weight	1.99 - 2 kg (4.39 - 4.41 lbs.)

SUPER JOINT SYSTEM
SJS**Die Grinder
GD0801C**

Continuous rating Input	750W
Collet size	8 mm (1/4")
Wheel diameter	25 mm
No load speed	29,000 min ⁻¹
Dimensions (L x W x H)	390 x 75 x 88 mm (15-3/8 x 2-15/16 x 3-1/2")
Net weight	1.96 - 1.97 kg (4.32 - 4.34 lbs.)

SUPER JOINT SYSTEM
SJS**Die Grinder
GD0601**

Continuous rating Input	400W
Collet size	3 / 6 mm (1/8 / 1/4")
Wheel diameter	38 mm (1-1/2")
No load speed	25,000 min ⁻¹
Dimensions (L x W x H)	359 x 82 x 82 mm (14-1/8 x 3-1/4 x 3-1/4")
Net weight	1.68 - 1.84 kg (3.7 - 4.06 lbs.)

**Die Grinder
GD0600**

Continuous rating Input	400W
Collet size	3 / 6 mm (1/8 / 1/4")
Wheel diameter	38 mm (1-1/2")
No load speed	25,000 min ⁻¹
Dimensions (L x W x H)	358 x 82 x 82 mm (14-1/8 x 3-1/4 x 3-1/4")
Net weight	1.71 - 1.87 kg (3.77 - 4.12 lbs.)



Die Grinder GD0603

Continuous rating Input	240W
Collet size	6 mm (1/4")
Wheel diameter	23 mm
No load speed	28,000 min ⁻¹
Diameter of grip portion	65 mm
Circumference of grip portion	203 mm
Dimensions (L x W x H)	289 x 64 x 67 mm (11-3/8 x 2-1/2 x 2-5/8")
Net weight	0.98 kg (2.16 lbs.)



Straight Grinder GS5000

Continuous rating Input	750W
Wheel diameter	125 mm (5")
Hole diameter	12.7, 20 mm (1/2" / 3/4")
No load speed	5,600 min ⁻¹
Dimensions (L x W x H)	590 x 189 x 116 mm (23-1/4 x 7-7/16 x 4-9/16")
Net weight	5 - 5.2 kg (11 - 11.5 lbs.)



Bench Grinder GB602W

Continuous rating Input	250W
Wheel diameter	150 mm (6")
Wheel width	6.4 mm (1/4") / 16 mm (5/8")
Hole diameter	12.7 mm (1/2")
H.P.	1/3
No load speed	2,850 min ⁻¹ (50 Hz) / 3,450 min ⁻¹ (60 Hz)
Dimensions (L x W x H)	375 x 348 x 286 mm (14-49/64 x 13-45/64 x 11-17/64")
Net weight	9.27 - 8.93 kg (19.69 - 20.44 lbs.)



Cordless Random Orbit Polisher DPO600

18V

Pad size	150 mm (6")
Orbits per minute	Normal mode: 0 - 6,800 min ⁻¹ Finishing mode: 0 - 5,200 min ⁻¹
Strokes per minute	Normal mode: 0 - 13,600 min ⁻¹ Finishing mode: 0 - 10,400 min ⁻¹
No load speed	Normal mode: 0 - 780 min ⁻¹ Finishing mode: 0 - 600 min ⁻¹
Orbit diameter	5.5 mm (7/32")
Dimensions (L x W x H)	530 x 148 x 126 mm (20-7/8 x 5-7/8 x 5")
Net weight	3.1 - 3.6 kg (6.9 - 7.9 lbs.)



LXI **BL** **XPT**



Random Orbit Polisher PO6000C

Continuous rating Input	900W
Pad size	150 mm (6")
Orbits per minute	0 - 6,800 min ⁻¹
Strokes per minute	0 - 13,600 min ⁻¹
No load speed	0 - 780 min ⁻¹
Orbit diameter	5.5 mm (7/32")
Dimensions (L x W x H)	451 x 148 x 126 mm (17-3/4 x 5-7/8 x 5")
Net weight	2.8 - 3 kg (6.2 - 6.5 lbs.)



Straight Grinder GS6000

Continuous rating Input	750W
Wheel diameter	150 mm (6")
Hole diameter	12.7, 20 mm (1/2" / 3/4")
No load speed	5,600 min ⁻¹
Dimensions (L x W x H)	590 x 216 x 130 mm (23-1/4 x 8-1/2 x 5-1/8")
Net weight	5.2 - 5.4 kg (11.4 - 12 lbs.)



Bench Grinder GB801

Continuous rating Input	550W
Wheel diameter	205 mm (8")
Wheel width	19 mm (3/4")
Hole diameter	15.88 mm (5/8")
H.P.	3/4
No load speed	2,850 min ⁻¹ (50 Hz) / 3,450 min ⁻¹ (60 Hz)
Dimensions (L x W x H)	395 x 265 x 333 mm (15-9/16 x 10-7/16 x 13-7/64")
Net weight	19.91 - 19.63 kg (43.89 - 43.28 lbs.)



Bench Grinder GB602

Continuous rating Input	250W
Wheel diameter	150 mm (6")
Wheel width	16 mm (5/8")
Hole diameter	12.7 mm (1/2")
H.P.	1/3
No load speed	2,850 min ⁻¹ (50 Hz) / 3,450 min ⁻¹ (60 Hz)
Dimensions (L x W x H)	375 x 205 x 286 mm (14-49/64 x 8 x 11-17/64")
Net weight	9.31 - 9.08 kg (20.02 - 20.52 lbs.)



Cordless Random Orbit Polisher DPO500

18V

Pad size	125 mm (5")
Orbits per minute	Normal mode: 0 - 6,800 min ⁻¹ Finishing mode: 0 - 5,200 min ⁻¹
Strokes per minute	Normal mode: 0 - 13,600 min ⁻¹ Finishing mode: 0 - 10,400 min ⁻¹
No load speed	Normal mode: 0 - 780 min ⁻¹ Finishing mode: 0 - 600 min ⁻¹
Orbit diameter	5.5 mm (7/32")
Dimensions (L x W x H)	530 x 123 x 134 mm (20-7/8 x 4-7/8 x 5-1/4")
Net weight	3.1 - 3.6 kg (6.9 - 7.9 lbs.)



LXI **BL** **XPT**



Random Orbit Polisher PO5000C

Continuous rating Input	900W
Pad size	125 mm (5")
Orbits per minute	0 - 6,800 min ⁻¹
Strokes per minute	0 - 13,600 min ⁻¹
No load speed	0 - 780 min ⁻¹
Orbit diameter	5.5 mm (7/32")
Dimensions (L x W x H)	451 x 123 x 134 mm (17-3/4 x 4-7/8 x 5-1/4")
Net weight	2.8 - 3 kg (6.2 - 6.5 lbs.)



Grinding/Sanding/Polishing

**Random Orbit Sander
BO6050**

Continuous rating Input	750W
Pad diameter	150 mm (6")
Abrasive disc size	150 mm (6")
Orbits per minute	1,600 - 6,800 min ⁻¹
Sanding strokes per minute	3,200 - 13,600 min ⁻¹
Pad speed in Roto-orbit mode	140 - 600 min ⁻¹
Orbit diameter	5.5 mm (7/32")
Dimensions (L x W x H)	330 x 155 x 145 mm (13 x 6-1/8 x 5-3/4")
Net weight	2.6 kg (5.7 lbs.)

**Random Orbit Sander
BO5041**

Continuous rating Input	300W
Pad diameter	123 mm (4-7/8")
Abrasive disc size	125 mm (5")
Orbits per minute	4,000 - 12,000 min ⁻¹
Dimensions (L x W x H)	218 x 123 x 153 mm (8-5/8 x 4-7/8 x 6")
Net weight	1.4 kg (3.1 lbs.)

**Random Orbit Sander
BO5040**

Continuous rating Input	300W
Pad diameter	123 mm (4-7/8")
Abrasive disc size	125 mm (5")
Orbits per minute	12,000 min ⁻¹
Dimensions (L x W x H)	218 x 123 x 153 mm (8-5/8 x 4-7/8 x 6")
Net weight	1.4 kg (3.1 lbs.)

**Orbital Sander
9046**

Continuous rating Input	600W
Pad size	115 x 229 mm (4-1/2 x 9")
Abrasive paper size	115 x 280 mm (4-1/2 x 11")
Orbits per minute	6,000 min ⁻¹
Overall length	283 mm (11-1/8")
Orbit diameter	5 mm (3/16")
Net weight	3.0 kg (6.6 lbs.)

**Battery Powered Random Orbit Sander
BO001CG**

40V max

new

Orbits per minute	6,000 - 10,000 min ⁻¹
Orbit diameter	5.0 mm (3/16")
Abrasive disc size	125 mm (5")
Dimensions (L x W x H)	234 x 123 x 96 mm (9-1/4 x 4-7/8 x 3-3/4")
Net weight (Tool only)	0.92 kg (2.0 lbs.)



XGT BL AWS XPT

**Random Orbit Sander
BO6030**

Continuous rating Input	310W
Pad diameter	150 mm (6")
Abrasive disc size	150 mm (6")
Orbits per minute	4,000 - 10,000 min ⁻¹
Orbit diameter	3.0 mm (1/8")
Overall length	309 mm (12-1/8")
Net weight	2.4 kg (5.2 lbs.)

**Random Orbit Sander
BO5031**

Continuous rating Input	300W
Pad diameter	123 mm (4-7/8")
Abrasive disc size	125 mm (5")
Orbits per minute	4,000 - 12,000 min ⁻¹
Dimensions (L x W x H)	153 x 123 x 153 mm (6 x 4-7/8 x 6")
Net weight	1.3 kg (3 lbs.)

**Random Orbit Sander
BO5030**

Continuous rating Input	300W
Pad diameter	123 mm (4-7/8")
Abrasive disc size	125 mm (5")
Orbits per minute	12,000 min ⁻¹
Dimensions (L x W x H)	153 x 123 x 153 mm (6 x 4-7/8 x 6")
Net weight	1.3 kg (2.9 lbs.)

**Battery Powered Random Orbit Sander
BO002CG**

40V max

new

Orbits per minute	6,000 - 10,000 min ⁻¹
Orbit diameter	5.0 mm (3/16")
Abrasive disc size	150 mm (6")
Dimensions (L x W x H)	247 x 148 x 96 mm (9-3/4 x 5-7/8 x 3-3/4")
Net weight (Tool only)	0.98 kg (2.2 lbs.)



XGT BL AWS XPT



Grinding/Sanding/Polishing

Battery Powered Random Orbit Sander BO003CG

40V max

new



Orbits per minute	6,000 - 10,000 min ⁻¹
Orbit diameter	3.0 mm (1/8")
Abrasive disc size	125 mm (5")
Dimensions (L x W x H)	233 x 123 x 96 mm (9-1/8 x 4-7/8 x 3-3/4")
Net weight (Tool only)	0.91 kg (2.0 lbs.)

XGT BL MOTOR AWS XPT



Battery Powered Orbital Sander BO005CG

40V max

new



Orbits per minute	6,000 - 10,000 min ⁻¹
Orbit diameter	3.0 mm (1/8")
Abrasive paper size	Square: 80 x 130 mm (3-1/8 x 5-1/8") Triangular: 100 x 150 mm (3-15/16 x 5-7/8")
Pad size	80 x 130 mm (3-1/8 x 5-1/8")
Dimensions (L x W x H)	236 x 80 x 99 mm (9-1/4 x 3-1/8 x 3-7/8")
Net weight (Tool only)	0.93 kg (2.1 lbs.)

XGT BL MOTOR AWS XPT



Battery Powered Orbital Sander BO007CG

40V max

new



Orbits per minute	6,000 - 12,000 min ⁻¹
Orbit diameter	2.0 mm (1/16")
Pad size	93 x 185 mm (3-5/8 x 7-1/4")
Dimensions (L x W x H)	263 x 92 x 106 mm (10-3/8 x 3-5/8 x 4-3/16")
Net weight (Tool only)	1.1 kg (2.4 lbs.)

XGT BL MOTOR AWS XPT



Battery Powered Random Orbit Sander BO004CG

40V max

new



Orbits per minute	6,000 - 10,000 min ⁻¹
Orbit diameter	3.0 mm (1/8")
Abrasive disc size	150 mm (6")
Dimensions (L x W x H)	246 x 148 x 96 mm (9-11/16 x 5-7/8 x 3-3/4")
Net weight (Tool only)	0.96 kg (2.1 lbs.)

XGT BL MOTOR AWS XPT



Battery Powered Orbital Sander BO006CG

40V max

new



Orbits per minute	6,000 - 10,000 min ⁻¹
Orbit diameter	3.0 mm (1/8")
Abrasive paper size	Square: 80 x 130 mm (3-1/8 x 5-1/8") Triangular: 100 x 150 mm (3-15/16 x 5-7/8")
Dimensions (L x W x H)	263 x 100 x 99 mm (10-3/8 x 3-15/16 x 3-7/8")
Net weight (Tool only)	0.93 kg (2.1 lbs.)

XGT BL MOTOR AWS XPT



Cordless Finishing Sander DBO480

18V



Orbits per minute	High: 14,000 min ⁻¹ / Low: 11,000 min ⁻¹
Strokes per minute	High: 28,000 min ⁻¹ / Low: 22,000 min ⁻¹
Orbit diameter	1.5 mm (1/16")
Abrasive paper size	Hook & Loop type: 114 x 102 mm (4-1/2 x 4") Clamp type: 140 x 114 mm (5-1/2 x 4-1/2")
Compatible Hook & Loop paper size	Square: 114 x 102 mm (4-1/2 x 4") Rectangular: 114 x 190 mm (4-1/2 x 7-1/2") Triangular: 96 x 96 mm (3-3/4 x 3-3/4")
Pad size	112 x 102 mm (4-3/8 x 4")
Dimensions (L x W x H)	w/ BL1830B / BL1840B / BL1850B / BL1860B: 171 x 112 x 152 mm (6-3/4 x 4-3/8 x 6")
Net weight	1.4 - 1.7 kg (3.1 - 3.8 lbs.)



Cordless Finishing Sander DBO481

18V



Orbits per minute	High: 14,000 min ⁻¹ / Low: 11,000 min ⁻¹
Strokes per minute	High: 28,000 min ⁻¹ / Low: 22,000 min ⁻¹
Orbit diameter	1.5 mm (1/16")
Abrasive paper size	Clamp type: 140 x 114 mm (5-1/2 x 4-1/2") Square: 114 x 102 mm (4-1/2 x 4")
Compatible Hook & Loop paper size	Rectangular: 114 x 190 mm (4-1/2 x 7-1/2") Triangular: 96 x 96 mm (3-3/4 x 3-3/4")
Pad size	112 x 102 mm (4-3/8 x 4")
Dimensions (L x W x H)	w/ BL1830B / BL1840B / BL1850B / BL1860B: 171 x 112 x 151 mm (6-3/4 x 4-3/8 x 5-15/16")
Net weight	1.4 - 1.7 kg (3.1 - 3.8 lbs.)



Cordless Finishing Sander DBO482

18V



Orbits per minute	High: 14,000 min ⁻¹ / Low: 11,000 min ⁻¹
Strokes per minute	High: 28,000 min ⁻¹ / Low: 22,000 min ⁻¹
Orbit diameter	1.5 mm (1/16")
Abrasive paper size	Clamp type: 140 x 114 mm (5-1/2 x 4-1/2") Square: 114 x 102 mm (4-1/2 x 4")
Compatible Hook & Loop paper size	Rectangular: 114 x 190 mm (4-1/2 x 7-1/2") Triangular: 96 x 96 mm (3-3/4 x 3-3/4")
Pad size	112 x 102 mm (4-3/8 x 4")
Dimensions (L x W x H)	w/ BL1830B / BL1840B / BL1850B / BL1860B: 171 x 112 x 150 mm (6-3/4 x 4-3/8 x 5-7/8")
Net weight	1.4 - 1.8 kg (3.1 - 4.0 lbs.)



Cordless Finishing Sander DBO484

18V



Orbits per minute	High: 14,000 min ⁻¹ / Low: 11,000 min ⁻¹
Strokes per minute	High: 28,000 min ⁻¹ / Low: 22,000 min ⁻¹
Orbit diameter	1.5 mm (1/16")
Abrasive paper size	Hook & Loop type: 114 x 102 mm (4-1/2 x 4") Clamp type: 140 x 114 mm (5-1/2 x 4-1/2")
Compatible Hook & Loop paper size	Square: 114 - 102 mm (4-1/2 - 4") Rectangular: 114 - 190 mm (4-1/2 - 7-1/2") Triangular: 96 - 96 mm (3-3/4 - 3-3/4")
Pad size	112 x 102 mm (4-3/8 x 4")
Dimensions (L x W x H)	w/ BL1830B / BL1840B / BL1850B / BL1860B: 171 x 112 x 151 mm (6-3/4 x 4-3/8 x 5-15/16")
Net weight	1.4 - 1.8 kg (3.1 - 4.0 lbs.)



Grinding/Sanding/Polishing

Cordless Finishing Sander DBO380

18V

Clamp
type paper Aluminum
base

Orbits per minute	4,000 / 8,000 / 12,000 min ⁻¹
Strokes per minute	8,000 / 16,000 / 24,000 min ⁻¹
Orbit diameter	2.0 mm (1/16")
Abrasive paper size	Rectangular: 93 x 228 mm (3-5/8 x 9")
Pad size	93 x 185 mm (3-5/8 x 7-1/4")
Dimensions (L x W x H)	w/ BL1830B / BL1840B / BL1850B / BL1860B: 336 x 92 x 169 mm (13-1/4 x 3-5/8 x 6-5/8")
Net weight	1.9 - 2.2 kg (4.2 - 4.9 lbs.)

LXI BL MOTOR XPT



Cordless Finishing Sander DBO381

18V

Clamp
type paper Aluminum
base

Orbits per minute	4,000 / 8,000 / 12,000 min ⁻¹
Strokes per minute	8,000 / 16,000 / 24,000 min ⁻¹
Orbit diameter	2.0 mm (1/16")
Abrasive paper size	Rectangular: 93 x 228 mm (3-5/8 x 9")
Pad size	93 x 185 mm (3-5/8 x 7-1/4")
Dimensions (L x W x H)	w/ BL1830B / BL1840B / BL1850B / BL1860B: 336 x 92 x 169 mm (13-1/4 x 3-5/8 x 6-5/8")
Net weight	1.9 - 2.2 kg (4.2 - 4.9 lbs.)

LXI BL AWS MOTOR XPT



Cordless Finishing Sander DBO382

18V

Hook & loop or Clamp
type paper Aluminum
base

Orbits per minute	4,000 / 8,000 / 12,000 min ⁻¹
Strokes per minute	8,000 / 16,000 / 24,000 min ⁻¹
Orbit diameter	2.0 mm (1/16")
Abrasive paper size	Hook & Loop type: 93 x 185 mm (3-5/8 x 7-1/4")
Clamp type:	93 x 228 mm (3-5/8 x 9")
Pad size	93 x 185 mm (3-5/8 x 7-1/4")
Dimensions (L x W x H)	w/ BL1830B / BL1840B / BL1850B / BL1860B: 336 x 92 x 169 mm (13-1/4 x 3-5/8 x 6-5/8")
Net weight	1.9 - 2.2 kg (4.2 - 4.9 lbs.)

LXI BL MOTOR XPT



Finishing Sander BO4900V



Continuous rating Input	330W
Orbits per minute	4,000 - 10,000 min ⁻¹
Abrasive paper size	115 x 232 mm (4-1/2 x 9-1/8")
Pad size	229 x 115 mm (9 x 4-1/2")
Overall length	289 mm (11-3/8")
Net weight	2.9 kg (6.4 lbs.)



Finishing Sander BO4900



Continuous rating Input	330W
Orbits per minute	10,000 min ⁻¹
Abrasive paper size	115 x 232 mm (4-1/2 x 9-1/8")
Pad size	229 x 115 mm (9 x 4-1/2")
Overall length	289 mm (11-3/8")
Net weight	2.9 kg (6.4 lbs.)



Finishing Sander BO4901



Continuous rating Input	330W
Orbits per minute	10,000 min ⁻¹
Abrasive paper size	115 x 280 mm (4-1/2 x 11")
Pad size	229 x 115 mm (9 x 4-1/2")
Overall length	289 mm (11-3/8")
Net weight	2.8 kg (6.2 lbs.)



Finishing Sander BO4556



Continuous rating Input	200W
Orbits per minute	14,000 min ⁻¹
Abrasive paper size	114 x 140 mm (4-1/2 x 5-1/2")
Pad size	102 x 112 mm (4 x 4-3/8")
Dimensions (L x W x H)	131 x 112 x 141 mm (5-1/8 x 4-3/8 x 5-9/16")
Net weight	1.1 kg (2.5 lbs.)



Finishing Sander BO4555



Continuous rating Input	200W
Orbits per minute	14,000 min ⁻¹
Abrasive paper size	114 x 102 mm (4-1/2 x 4")
Pad size	102 x 112 mm (4 x 4-3/8")
Dimensions (L x W x H)	131 x 112 x 141 mm (5-1/8 x 4-3/8 x 5-9/16")
Net weight	1.1 kg (2.5 lbs.)



Finishing Sander BO4558



Continuous rating Input	200W
Orbits per minute	14,000 min ⁻¹
Abrasive paper size	114 x 140 mm (4-1/2 x 5-1/2")
Pad size	102 x 112 mm (4 x 4-3/8")
Dimensions (L x W x H)	131 x 112 x 141 mm (5-1/8 x 4-3/8 x 5-9/16")
Net weight	1.2 kg (2.5 lbs.)



Grinding/Sanding/Polishing

Finishing Sander BO4565

Continuous rating Input	200W
Orbits per minute	14,000 min ⁻¹
Abrasive paper size	114 x 102 mm (4-1/2 x 4")
Pad size	112 x 190 mm (4-3/8 x 7-1/2")
Dimensions (L x W x H)	219 x 112 x 139 mm (8-5/8 x 4-3/8 x 5-1/2")
Net weight	1.2 kg (2.6 lbs.)



Finishing Sander BO4566

Continuous rating Input	200W
Orbits per minute	14,000 min ⁻¹
Abrasive paper size	102 x 166 mm (4 x 6-1/2")
Pad size	164 x 100 mm (6-1/2 x 3-15/16")
Dimensions (L x W x H)	197 x 100 x 137 mm (7-3/4 x 3-15/16 x 5-3/8")
Net weight	1.2 kg (2.6 lbs.)



Finishing Sander BO3711

Continuous rating Input	190W
Orbits per minute	4,000 - 11,000 min ⁻¹
Strokes per minute	8,000 - 22,000 min ⁻¹
Orbit diameter	2.0 mm (1/16")
Abrasive paper size	93 x 228 mm (3-5/8 x 9")
Pad size	185 x 93 mm (7-1/4 x 3-5/8")
Dimensions (L x W x H)	253 x 92 x 154 mm (10 x 3-5/8 x 6-1/16")
Net weight	1.6 kg (3.5 lbs.)



Finishing Sander BO3710

Continuous rating Input	190W
Orbits per minute	11,000 min ⁻¹
Strokes per minute	22,000 min ⁻¹
Orbit diameter	2.0 mm (1/16")
Abrasive paper size	93 x 228 mm (3-5/8 x 9")
Pad size	185 x 93 mm (7-1/4 x 3-5/8")
Dimensions (L x W x H)	253 x 92 x 154 mm (10 x 3-5/8 x 6-1/16")
Net weight	1.6 kg (3.5 lbs.)



Finishing Sander BO4557

Continuous rating Input	180W
Orbits per minute	14,000 min ⁻¹
Abrasive paper size	114 x 140 mm (4-1/2 x 5-1/2")
Pad size	102 x 112 mm (4 x 4-3/8")
Dimensions (L x W x H)	131 x 112 x 137 mm (5-1/8 x 4-3/8 x 5-3/8")
Net weight	1 kg (2.1 lbs.)



Finishing Sander 9035H

Continuous rating Input	180W
Orbits per minute	11,000 min ⁻¹
Abrasive paper size	93 x 228 mm (3-5/8 x 9")
Pad size	185 x 93 mm (7-1/4 x 3-5/8")
Dimensions (L x W x H)	236 x 93 x 146 mm (9-1/4 x 3-5/8 x 5-3/4")
Net weight	1.5 kg (3.3 lbs.)



Finishing Sander BO4510H

Continuous rating Input	170W
Orbits per minute	12,000 min ⁻¹
Abrasive paper size	114 x 140 mm (4-1/2 x 5-1/2")
Pad size	100 x 110 mm (3-15/16 x 4-5/16")
Dimensions (L x W x H)	116 x 110 x 129 mm (4-9/16 x 4-5/16 x 5-1/8")
Net weight	1.1 kg (2.4 lbs.)



Cordless Random Orbit Sander DBO180

Orbits per minute	7,000 / 9,500 / 11,000 min ⁻¹
Abrasive disc size	125 mm (5")
Pad diameter	123 mm (4-7/8")
Dimensions (L x W x H)	175 x 123 x 153 mm (6-7/8 x 4-7/8 x 6")
Net weight	1.4 - 1.7 kg (3 - 3.7 lbs.)



LXT



Cordless Drywall Sander DSL801

Abrasive disc size	225 mm (8-7/8")
Pad diameter	210 mm (8-1/4")
No load speed	1,000 - 1,800 min ⁻¹
Dimensions (L x W x H)	1,120 - 1,540 x 278 x 273 mm (44 - 60-1/2 x 11 x 10-3/4")
Net weight	4.6 - 5.8 kg (10.1 - 12.8 lbs.)



LXT BL MOTOR AWS XPT



Grinding/Sanding/Polishing

Cordless Belt Sander
BS001G

40V max

new



Belt width	76 mm (3")
Belt length	533 mm (21")
Belt speed	120 - 470 m/min (390 - 1,540 ft/min)
Dimensions (L x W x H)	440 x 148 x 165 mm (17-1/4 x 5-7/8 x 6-1/2")
Net weight	4.5 - 5.1 kg (9.9 - 11.2 lbs.)

XGT BL MOTOR AWS XPT

**Belt Sander**
9403

Continuous rating Input	1,200W
Belt size	100 x 610 mm (4 x 24")
Belt speed	500 m/min (1,640 ft/min)
Overall length	353 mm (13-7/8")
Net weight	5.9 kg (13 lbs.)

**Belt Sander**
9920

Continuous rating Input	1,010W
Belt size	76 x 610 mm (3 x 24")
Belt speed	210 - 440 m/min (690 - 1,440 ft/min)
Overall length	334 mm (13-1/8")
Net weight	4.5 kg (9.9 lbs.)

**Belt Sander**
9903

Continuous rating Input	1,010W
Belt size	76 x 533 mm (3 x 21")
Belt speed	210 - 440 m/min (690 - 1,440 ft/min)
Overall length	296 mm (11-5/8")
Net weight	4.3 kg (9.5 lbs.)

**Belt Sander**
9910

Continuous rating Input	650W
Belt size	76 x 457 mm (3 x 18")
Belt speed	270 m/min (900 ft/min)
Overall length	262 mm (10-5/16")
Net weight	2.7 kg (6 lbs.)

**Cordless Belt Sander**
DBS180

18V



Belt width	6 / 9 / 13 mm (1/4 / 3/8 / 1/2")
Belt length	533 mm (21")
Belt speed	600 - 1,700 m/min
Dimensions (L x W x H)	w/ BL1830B / BL1840B / BL1850B / BL1860B: 500 x 96 x 116 mm (19-3/4 x 3-3/4 x 4-9/16")
Net weight	1.8 - 2.1 kg (4.0 - 4.6 lbs.)

LXT BL MOTOR

**Belt Sander**
9404

Continuous rating Input	1,010W
Belt size	100 x 610 mm (4 x 24")
Belt speed	210 - 440 m/min (690 - 1,440 ft/min)
Overall length	334 mm (13-1/8")
Net weight	4.7 kg (10.3 lbs.)

**Belt Sander**
9924DB

Continuous rating Input	850W
Belt size	76 x 610 mm (620 x 3")
Belt speed	400 m/min (1,300 ft/min)
Overall length	355 mm (14")
Net weight	4.8 kg (10.6 lbs.)

**Belt Sander**
9911

Continuous rating Input	650W
Belt size	76 x 457 mm (3 x 18")
Belt speed	75 - 270 m/min (250 - 900 ft/min)
Overall length	262 mm (10-3/8")
Net weight	2.7 kg (6 lbs.)

**Belt Sander**
9031

Continuous rating Input	550W
Belt size	30 x 533 mm (1-3/16 x 21")
Belt speed	200 - 1,000 m/min (656 - 3,280 ft/min)
Overall length	380 mm (15")
Net weight	2.1 kg (4.6 lbs.)



Grinding/Sanding/Polishing

Belt Sander 9032

Continuous rating Input	500W
Belt size	6 - 13 x 533 mm (1/4 - 1/2 x 21")
Belt speed	300 - 1,700 m/min (980 - 5,600 ft/min)
Max sanding depth	110 mm (4-5/16")
Overall length	420 mm (16-1/2")
Net weight	1.6 kg (3.5 lbs.)



Wheel Sander 9741

Continuous rating Input	860W
Wheel diameter	100 x 120 mm (4 x 4-3/4")
No load speed	3,500 min ⁻¹
Overall length	310 mm (12-1/4")
Net weight	4.2 kg (9.3 lbs.)



PRODUCTS

Cutting



-  Double Insulation
-  Variable Speed
-  Brake
-  Reversing
-  Anti-restart function
-  Constant Speed
-  Soft Start
-  Bevel Cutting 45 left
-  Orbital Cutting
-  Bayonet Shank Jig Saw Blade
-  Dust Collection
-  Toolless blade change
-  Built-in Job Light
-  Carrying Case

Cutting

Cordless Dustless Cutter DCC500

18V



Wheel diameter	125 mm (5")
Hole diameter	20 mm (13/16")
Max cutting capacity	0°: 40 mm (1-9/16") 45°: 27 mm (1-1/16")
No load speed	8,800 min ⁻¹
Dimensions (L x W x H)	w/ BL1830B / BL1840B / BL1850B / BL1860B: 283 x 158 x 172 mm (11-1/8 x 6-1/4 x 6-3/4")
Net weight	2.5 - 3.0 kg (5.5 - 6.6 lbs.)

LXI MOTOR ADT AWS XPT



Cordless Cutter DCC501

18V



Wheel diameter	125 mm (5")
Hole diameter	20 mm (13/16")
Max cutting capacity	0°: 40 mm (1-9/16") 45°: 27 mm (1-1/16")
No load speed	8,800 min ⁻¹
Dimensions (L x W x H)	w/ Water supply tank, w/ BL1830B / BL1840B / BL1850B / BL1860B: 283 x 163 x 291 mm (11-1/8 x 6-3/8 x 11-1/2")
Net weight	2.7 - 3.0 kg (6.0 - 6.6 lbs.)

LXI MOTOR ADT AWS XPT



Cordless Cutter CC301D

12V max



Wheel diameter	85 mm (3-3/8")
Hole diameter	15 mm (9/16")
Max cutting capacity	0°: 25.5 mm (1") 45°: 16.5 mm (5/8")
No load speed	1,600 min ⁻¹
Tank capacity	0.5 L
Dimensions (L x W x H)	313 x 170 x 125 mm (12-3/8 x 6-11/16 x 4-7/8")
Net weight	1.9 kg (4.1 lbs.)

CXT



Dustless Cutter 4100KB

12V max



Continuous rating Input	1,400W
Wheel diameter	125 mm (5")
Hole diameter	20 mm (13/16")
Max cutting capacity	40.0 mm (1-9/16")
No load speed	12,200 min ⁻¹
Dimensions (L x W x H)	231 x 220 x 179 mm (9-1/8 x 8-5/8 x 7")
Net weight	3 kg (6.6 lbs.)



Cutter 4100NH3

12V max



Continuous rating Input	1,300W
Wheel diameter	130 mm (5-1/8")
Max cutting capacity	110 mm (4-3/8")
No load speed	0°: 32 mm (1-1/4") 45°: 22 mm (7/8")
Dimensions (L x W x H)	227 x 209 x 166 mm (8-15/16 x 8-1/4 x 6-1/2")
Net weight	2.8 kg (6.2 lbs.)



Cutter 4100NH2

12V max



Continuous rating Input	1,400W
Wheel diameter	110 - 125 mm (4-3/8 - 5")
Max cutting capacity	0°: 32.5 mm (1-1/4") 45°: 21.5 mm (7/8")
Dimensions (L x W x H)	w/ 110mm (4-3/8") wheel 45°: 21.5 mm (7/8") 0°: 40.0 mm (1-9/16") 45°: 27.0 mm (1-1/16")
No load speed	12,200 min ⁻¹
Dimensions (L x W x H)	238 x 214 x 169 mm (9-3/8 x 8-3/8 x 6-5/8")
Net weight	3 kg (6.6 lbs.)



Cutter 4101RH

12V max



Continuous rating Input	860W
Wheel diameter	125 mm (5")
Max cutting capacity	0°: 41.5 mm (1-5/8") 45°: 26 mm (1")
No load speed	12,000 min ⁻¹
Overall length	236 mm (9-5/16")
Net weight	3 kg (11.5 lbs.)



Cutter 4107R

12V max



Continuous rating Input	1,400W
Wheel diameter	180 mm (7-1/8")
Hole diameter	25/25.4 mm (1/1")
Capacity	Max cutting: 60 mm (2-3/8")
No load speed	5,000 min ⁻¹
Overall length	370 mm (14-9/16")
Net weight	6.3 kg (14.5 lbs.)



Cutter 4100NH2R

12V max



Continuous rating Input	1,450W
Wheel diameter	110 mm (4-3/8")
No load speed	12,200 min ⁻¹
Max cutting capacity	45°: 24.5 mm (15/16") 48°: 23.5 mm (15/16")
Dimensions (L x W x H)	398 x 365 x 267 mm (15-5/8 x 14-3/8 x 10-1/2")
Net weight	6.5 kg (14.2 lbs.)



Roller base

Cutter 4100NH2W

12V max



Continuous rating Input	1,450W
Wheel diameter	110 mm (4-3/8")
Max cutting capacity	45°: 24.5 mm (15/16") 48°: 23.5 mm (15/16")
No load speed	12,200 min ⁻¹
Dimensions (L x W x H)	398 x 365 x 267 mm (15-5/8 x 14-3/8 x 10-1/2")
Net weight	6.3 kg (13.8 lbs.)



Wet cutting base

Cutting

Cordless Metal Cutter
CS002G

40V max



Wheel diameter	185 mm (7-1/4")
Max cutting capacity	0°: 67 mm (2-5/8")
No load speed	3,500 min ⁻¹
Dimensions (L x W x H)	350 x 232 x 270 mm (13-3/4 x 9-1/8 x 10-5/8")
Net weight	4.2 - 5.4 kg (9.3 - 11.9 lbs.)

XGT BL MOTOR XPT

Cordless Metal Cutter
DCS553

18V



Wheel diameter	150 mm (5-7/8")
Max cutting capacity	0°: 57.5 mm (2-1/4")
No load speed	4,200 min ⁻¹
Dimensions (L x W x H)	267 x 186 x 250 mm (10-1/2 x 7-3/8 x 9-7/8")
Net weight	2.8 - 3.1 kg (6.1 - 6.8 lbs.)

LXI BL MOTOR ADT XPT

Cordless Metal Cutter
DCS552

18V



Wheel diameter	136 mm (5-3/8")
Max cutting capacity	0°: 50.5 mm (2")
No load speed	3,600 min ⁻¹
Dimensions (L x W x H)	348 x 196 x 203 mm (13-3/4 x 7-3/4 x 8")
Net weight	2.4 - 2.7 kg (5.3 - 6.0 lbs.)

LXI

Metal Cutter
4131

Continuous rating Input	1,100W
Wheel diameter	185 mm (7-1/4")
Hole diameter	15.88 / 20 / 30 mm (5/8 / 13/16 / 1-3/16")
Capacity	Max cutting: 63 mm (2-1/2")
No load speed	3,500 min ⁻¹
Overall length	358 mm (14-1/8")
Net weight	4.8 kg (11.3 lbs.)

Metal Cutting Saw
LC1230

Continuous rating Input	1,750W
Wheel diameter	305 mm (12")
Hole diameter	25.4 mm (1")
Max cutting capacity	0°: 115 mm (4-1/2") 45°: 90 mm (3-1/2")
No load speed	1,300 min ⁻¹
Dimensions (L x W x H)	516 x 306 x 603 mm (20-1/4 x 12 x 23-3/4")
Net weight	19.3 kg (42.5 lbs.)

Cordless Power Cutter
CE002G

40V max x2



Wheel diameter	355 mm (14")
Max cutting capacity	127 mm (5")
No load speed	4,200 min ⁻¹
Dimensions (L x W x H)	825 x 272 x 487 mm (32-1/2 x 10-3/4 x 19-1/4")
Net weight	13.1 - 15.1 kg (28.9 - 33.3 lbs.)

XGT BL MOTOR AFT AWS

Cordless Power Cutter
CE001G

40V max x2



Wheel diameter	355 mm (14")
Max cutting capacity	127 mm (5")
No load speed	5,300 min ⁻¹
Dimensions (L x W x H)	w/ BL4080F: 786 x 283 x 433 mm (31 x 11-1/8 x 17")
Net weight	12.2 - 14.1 kg (26.9 - 31.1 lbs.)

XGT BL MOTOR AFT XPT

Cordless Power Cutter
CE004G

40V max



Wheel diameter	305 mm (12")
Max cutting capacity	121 mm (4-3/4")
No load speed	5,000 min ⁻¹
Dimensions (L x W x H)	663 x 240 x 406 mm (26-1/8 x 9-1/2 x 16")
Net weight	6.7 - 7.7 kg (14.8 - 17.0 lbs.)

XGT BL MOTOR AFT XPT

Cordless Power Cutter
CE003G

40V max



new

Wheel diameter	230 mm (9")
Max cutting capacity	88 mm (3-1/2")
No load speed	6,600 min ⁻¹
Dimensions (L x W x H)	603 x 240 x 350 mm (23-3/4 x 9-1/2 x 13-3/4")
Net weight	6.4 - 7.4 kg (14.1 - 16.3 lbs.)

XGT BL MOTOR AFT XPT

Cordless Power Cutter
DCE090

18V x2



Wheel diameter	230 mm (9")
Max cutting capacity	88 mm (3-1/2")
No load speed	6,600 min ⁻¹
Dimensions (L x W x H)	554 x 241 x 283 mm (21-3/4 x 9-1/2 x 11-1/8")
Net weight	5.6 - 6.3 kg (12.3 - 13.9 lbs.)

LXI BL MOTOR AFT XPT



Cutting

Angle Cutter 4114S



Continuous rating Input	2,400W
Wheel diameter	355 mm (14")
Capacity	Max cutting: 125 mm (5")
No load speed	3,500 min ⁻¹
Dimensions (L x W x H)	673 x 240 x 329 mm (26-1/2 x 9-1/2 x 13")
Net weight	10.8 kg (23.9 lbs.)



Angle Cutter 4114



Continuous rating Input	1,650W
Wheel diameter	355 mm (14")
Capacity	Max cutting: 125 mm (5")
No load speed	3,500 min ⁻¹
Dimensions (L x W x H)	673 x 240 x 329 mm (26-1/2 x 9-1/2 x 13")
Net weight	12 kg (26.5 lbs.)



Wall Chaser SG1251



Continuous rating Input	1,400W
Blade diameter	125 mm (5")
Capacity	Depth: 0 - 30 mm (0 - 1-3/16") Width: 6 - 30 mm (1/4 - 1-3/16")
No load speed	10,000 min ⁻¹
Dimensions (L x W x H)	350 x 151 x 178 mm (13-3/4 x 5-15/16 x 7")
Net weight	4.3 kg (9.5 lbs.)



Aluminum Groove Cutter CA5000



Continuous rating Input	1,300W
Wheel diameter	118 mm (4-5/8")
Hole diameter	20 mm (13/16")
Max cutting capacity w/ Cutter blade	w/ Guide rail: 11 mm (7/16")
Max cutting capacity w/ TCT Saw blade	w/ Guide rail: 36 mm (1-7/16") w/o Guide rail: 41 mm (1-5/8")
No load speed	2,200 - 6,400 min ⁻¹
Dimensions (L x W x H)	346 x 250 x 250 mm (13-5/8 x 9-7/8 x 9-7/8")
Net weight	4.7 kg (10.4 lbs.)



Cordless Portable Cut-off DLW140

18V x2



Wheel diameter	355 mm (14")
Hole diameter	25.4 mm (1")
Capacity at 0°	Round: 127 mm (5")
Capacity at 45°	Round: 127 mm (5") Rectangular: 115 x 103 mm (4-1/2 x 4-1/16")
Capacity at 90°	Rectangular: 115, 102, 70 x 130, 194, 233 mm (4-1/2, 4, 2-3/4 x 5-1/8, 7-5/8, 9-1/8")
Dimensions (L x W x H)	w/ European type safety guard: 537 x 290 x 640 mm (21-1/8 x 11-3/8 x 25-1/4")
Net weight	17.2 - 17.8 kg (37.9 - 39.3 lbs.)



Portable Cut-off 2416S



Continuous rating Input	1,430W
Wheel diameter	405 mm (16")
Hole diameter	25.4 mm (1")
No load speed	2,300 min ⁻¹
Dimensions (L x W x H)	610 x 265 x 535 mm (24 x 10-3/8 x 21")
Net weight	19.2 kg (42.3 lbs.)

Portable Cut-off LW1400



Continuous rating Input	2,200W
Wheel diameter	355 mm (14")
Hole diameter	25.4 mm (1")
Capacity at 0°	Round: 127 mm (5")
Capacity at 45°	Round: 127 mm (5") Rectangular: 115 x 103 mm (4-1/2 x 4-1/16")
Capacity at 90°	Rectangular: 115, 102, 70 x 233, 194, 130 mm (4-1/2, 4, 2-3/4 x 9-1/8, 7-5/8, 5-1/8")
No load speed	3,800 min ⁻¹
Dimensions (L x W x H)	530 x 295 x 640 mm (20-7/8 x 11-5/8 x 25-1/4")
Net weight	18.7 kg (41.2 lbs.)



Portable Cut-off LW1401



Continuous rating Input	2,200W
Wheel diameter	355 mm (14")
Hole diameter	25.4 mm (1")
No load speed	3,800 min ⁻¹
Capacity at 0°	Round: 127 mm (5")
Capacity at 45°	Round: 127 mm (5") Rectangular: 115 x 103 mm (4-1/2 x 4-1/16")
Capacity at 90°	Rectangular: 115, 102, 70 x 130, 194, 233 mm (4-1/2, 4, 2-3/4 x 5-1/8, 7-5/8, 9-1/8")
Dimensions (L x W x H)	500 x 295 x 640 mm (19-3/4 x 11-5/8 x 25-1/4")
Net weight	18.3 kg (40.3 lbs.)



Cordless Steel Rod Cutter DSC251

18V



Blade diameter	110 mm (4-5/16")
Cutting capacity	Dia.: 10 - 25 mm (3/8 - 1")
No load speed	2,200 min ⁻¹
Dimensions (L x W x H)	471 x 137 x 139 mm (18-1/2 x 5-25/64 x 5-15/32")
Net weight	4.0 kg (8.8 lbs.)



Cutting

Cordless Steel Rod Cutter
DSC191

18V



Cutting capacity	Dia.: 3 - 20 mm (1/8 - 3/4")
Cutting speed (sec)	6.5
Dimensions (L x W x H)	412 x 212 x 284 mm (16-1/5 x 8-3/8 x 11-1/8")
Net weight	11.1 - 11.2 kg (24.5 - 24.6 lbs.)

LXT

Cordless Threaded Rod Cutter
DSC121

18V



Capacity	Steel: 8 - 12 mm (5/16 - 1/2")
Cutting speed (sec)	3.0
Dimensions (L x W x H)	w/ BL1830B / BL1840B / BL1850B / BL1860B: 212 x 323 x 260 mm (8-3/8 x 12-3/4 x 10-1/4")
Net weight	6.0 kg (13.2 lbs.)

LXT BL MOTOR

Cordless Threaded Rod Cutter
SC103D

12V max



Max cutting capacity	Mild steel: M10 Stainless steel: W3/8
Min. cutting length	20 mm (13/16")
Dimensions (L x W x H)	w/ BL1041B: 180 x 107 x 289 mm (7-1/8 x 4-1/4 x 11-3/8")
Net weight	2.7 - 2.8 kg (6.0 - 6.2 lbs.)

CXI BL MOTOR

Cordless Multi Cutter
CP100D

12V max



Max cutting capacity	6 mm (1/4")
No load speed	300 min ⁻¹
Dimensions (L x W x H)	w/ BL1041B: 291 x 66 x 121 mm (11-1/2 x 2-5/8 x 4-3/4")
Net weight	0.72 - 0.88 kg (1.6 - 1.9 lbs.)

CXI

Cordless Portable Band Saw
DPB180

18V



Capacity	Round: 120 mm (4-3/4") Rectangular: 120 x 120 mm (4-3/4 x 4-3/4")
Blade speed	1.4 - 275 m/min (2.7 - 530 ft/min)
Blade size	Length: 1,140 mm (44-7/8") Width: 13 mm (1/2") Thickness: 0.5 mm (0.02")
Dimensions (L x W x H)	523 x 231 x 313 mm (20-5/8 x 9-1/8 x 12-3/8")
Net weight	6.8 - 7.1 kg (14.9 - 15.7 lbs.)

LXT

Cordless Steel Rod Cutter
DSC163

18V



Cutting capacity	Dia.: 3 - 16 mm (1/8 - 5/8")
Cutting speed (sec)	2.8
Dimensions (L x W x H)	360 x 108 x 276 mm (14-1/8 x 4-1/4 x 10-7/8")
Net weight	6.9 kg (15.2 lbs.)

LXT

Cordless Threaded Rod Cutter
DSC102

18V



Capacity	Mild steel: W3/8, M10, M8, M6 Stainless steel: W3/8, M8, M6
Min. cutting length	20 mm (13/16")
Dimensions (L x W x H)	w/ BL1830B / BL1840B / BL1850B / BL1860B: 199 x 103 x 308 mm (7-7/8 x 4-1/16 x 12-1/8")
Net weight	2.8 - 3.2 kg (6.2 - 7 lbs.)

LXT BL MOTOR

Cordless Compact Cut Off
DMC300

18V



Wheel diameter	76 mm (3")
Hole diameter	9.5, 10.0 mm (3/8, 13/32")
Wheel plate thickness	1.0 mm (1/32")
Max cutting capacity	w/ Dust cover attachment: 13.5 mm (1/2") w/o Dust cover attachment: 16.0 mm (5/8")
No load speed	20,000 min ⁻¹
Dimensions (L x W x H)	w/ BL1830B / BL1840B / BL1850B / BL1860B: 271 x 104 x 182 mm (10-5/8 x 4-1/8 x 7-1/8")
Net weight	1.2 - 1.7 kg (2.6 - 3.7 lbs.)

LXT BL MOTOR AFT XPT

Cordless Portable Band Saw
PB002G

40V max



Capacity	Round: 127 mm (5") Square: 127 x 127 mm (5 x 5")
Blade speed	0 - 3.2 m/s (0 - 630 ft/min.)
Blade size	Length: 1,140 mm (45") Width: 13 mm (1/2") Thickness: 0.5 mm (0.02")
Dimensions (L x W x H)	w/ BL4080F: 510 x 218 x 346 mm (20 x 8-5/8 x 13-5/8")
Net weight	6.6 - 7.8 kg (14.6 - 17.2 lbs.)

XGT BL MOTOR XPT

Cordless Portable Band Saw
DPB183

18V



Capacity	Round: 66 mm (2-5/8") Square: 66 x 66 mm (2-5/8 x 2-5/8")
Blade speed	0 - 3.2 m/s (0 - 630 ft/min.)
Blade size	Length: 835 mm (32-7/8") Width: 13 mm (1/2") Thickness: 0.5 mm (0.02")
Dimensions (L x W x H)	392 x 174 x 242 mm (15-1/2 x 6-7/8 x 9-1/2")
Net weight	3.6 - 3.9 kg (7.9 - 8.6 lbs.)

LXT BL MOTOR



Cutting

Cordless Portable Band Saw DPB182

18V



Capacity	Round: 64 mm (2-1/2") Rectangular: 64 x 64 mm (2-1/2 x 2-1/2")
Blade speed	3.2 m/s (630 ft/min.)
Blade size	Length: 835 mm (32-7/8") Width: 13 mm (1/2") Thickness: 0.5 mm (0.02")
Dimensions (L x W x H)	477 x 197 x 229 mm (18-3/4 x 7-3/4 x 9")
Net weight	3.8 - 4.1 kg (8.3 - 9.0 lbs.)

LXT



Cordless Portable Band Saw DPB184

18V



Capacity	Round: 51 mm (2") Square: 51 x 51 mm (2 x 2")
Blade speed	0 - 3.2 m/s (0 - 630 ft/min.)
Blade size	Length: 730 mm (28-3/4") Width: 13 mm (1/2") Thickness: 0.5 mm (0.02")
Dimensions (L x W x H)	w/ BL1830B / BL1840B / BL1850B / BL1860B: 373 x 162 x 223 mm (14-3/4 x 6-3/8 x 8-3/4")
Net weight	3.3 - 3.6 kg (7.3 - 7.9 lbs.)

LXT **BL MOTOR**



Portable Band Saw 2107F



Continuous rating Input	710W
Capacity	Round: 120 mm (4-3/4") Rectangular: 120 x 120 mm (4-3/4 x 4-3/4")
Blade speed	1.0 - 1.7 m/s
Blade size	Length: 1,140 mm Width: 13 mm Thickness: 0.5 mm
Dimensions (L x W x H)	508 x 188 x 256 mm (20 x 7-3/8 x 10-1/8")
Net weight	6.3 kg (13.9 lbs.)



Cutting

Cordless Hole Puncher PP001G

40V max

new



Capacity	Steel: 20 mm Stainless steel: 20 mm
Dimensions (L x W x H)	w/ BL4020 / BL4025: 398 x 129 x 315 mm (15-5/8 x 5-1/8 x 12-3/8")
Net weight	11.6 - 12.8 kg (25.6 - 28.2 lbs.)

XGT **BL MOTOR**



Cordless Hole Puncher DPP200

18V



Capacity	Steel: 20 mm (13/16") Stainless steel: 20 mm (13/16")
Max throat depth	40 mm (1-9/16")
Dimensions (L x W x H)	w/ BL1830B / BL1840B / BL1850B / BL1860B: 417 x 127 x 315 mm (16-3/8 x 5 x 12-3/8")
Net weight	10.5 kg (23.2 lbs.)

LXT

Cordless Metal Shear DJS200

18V



Max cutting capacity	Steel: 2.0 mm (14 gauge) Stainless steel: 1.6 mm (16 gauge)
Strokes per minute	0 - 3,000 min ⁻¹
Dimensions (L x W x H)	w/ BL1830B / BL1840B / BL1850B / BL1860B: 345 x 79 x 207 mm (13-5/8 x 3-1/8 x 8-1/8")
Net weight	2.2 - 2.5 kg (4.9 - 5.5 lbs.)

LXT **BL MOTOR** **XPT**



Cordless Metal Shear DJS131

18V



Max cutting capacity	Steel: 1.3 mm (18 gauge) Stainless steel: 1.0 mm (20 gauge)
Strokes per minute	0 - 3,000 min ⁻¹
Dimensions (L x W x H)	w/ BL1830B / BL1840B / BL1850B / BL1860B: 332 x 79 x 252 mm (13-1/8 x 3-1/8 x 9-7/8")
Net weight	2.0 - 2.3 kg (4.4 - 5.1 lbs.)

LXT **BL MOTOR** **XPT**



Cordless Metal Shear DJS130

18V



Capacity	Steel up to 400 N/mm ² : 1.3 mm Steel up to 600 N/mm ² : 1.0 mm
No load speed	2,800 min ⁻¹
Dimensions (L x W x H)	350 x 80 x 193 mm (13-3/4 x 3-1/8 x 7-5/8")
Net weight	2.3 - 2.6 kg (5 - 5.8 lbs.)

LXT

Cordless Straight Shear DJS161

18V



Capacity	Steel up to 400 N/mm ² : 1.6 mm Steel up to 600 N/mm ² : 1.2 mm Aluminum up to 200 N/mm ² : 2.5 mm
Strokes per minute	4,300 min ⁻¹
Dimensions (L x W x H)	362 x 78 x 118 mm (14-1/4 x 3-1/16 x 4-5/8")
Net weight	1.8 - 2.2 kg (4.1 - 4.8 lbs.)

LXT



Cutting

Cordless Metal Shear
DJS101

18V



Capacity	Steel up to 400 N/mm ² : 1.0 mm Steel up to 600 N/mm ² : 0.7 mm Aluminum up to 200 N/mm ² : 2.5 mm
Strokes per minute	4,300 min ⁻¹
Dimensions (L x W x H)	364 x 78 x 118 mm (14-3/8 x 3-1/16 x 4-5/8")
Net weight	1.8 - 2.2 kg (4 - 4.7 lbs.)

LXT

Cordless Cement Shear
DJS800

18V



Max cutting capacity	13 mm (1/2")
Strokes per minute	0 - 3,000 min ⁻¹
Dimensions (L x W x H)	w/ BL1830B / BL1840B / BL1850B / BL1860B: 379 x 79 x 216 mm (14-7/8 x 3-1/8 x 8-1/2")
Net weight	2.1 - 2.5 kg (4.6 - 5.5 lbs.)

LXT BL MOTOR XPT

Straight Metal Shear
JS1601

Continuous rating Input	380W
Capacity	Steel up to 400 N/mm ² : 1.6 mm Steel up to 600 N/mm ² : 1.2 mm Steel up to 800 N/mm ² : 0.8 mm Aluminum up to 200 N/mm ² : 2.5 mm
Min. cutting radius	250 mm (9-7/8")
Strokes per minute	4,500 min ⁻¹
Dimensions (L x W x H)	320 x 70 x 78 mm (12-5/8 x 2-3/4 x 3-1/16")
Net weight	1.4 kg (3.2 lbs.)

Metal Shear
JS1602

Continuous rating Input	380W
Capacity	Steel up to 400 N/mm ² : 1.6 mm Steel up to 600 N/mm ² : 1.2 mm Steel up to 800 N/mm ² : 0.8 mm Aluminum up to 200 N/mm ² : 2.5 mm
Min. cutting radius	30 mm (1-3/16")
Strokes per minute	4,000 min ⁻¹
Dimensions (L x W x H)	255 x 74 x 146 mm (10 x 2-15/16 x 5-3/4")
Net weight	1.6 kg (3.4 lbs.)

Nibbler
JN1601

Continuous rating Input	550W
Capacity	Steel up to 400 N/mm ² : 1.6 mm Steel up to 600 N/mm ² : 1.2 mm Steel up to 800 N/mm ² : 0.8 mm Aluminum up to 200 N/mm ² : 2.5 mm
Min. cutting radius	Outside edge: 50 mm (2") Inside edge: 45 mm (1-3/4")
Strokes per minute	2,200 min ⁻¹
Overall length	261 mm (10-1/4")
Net weight	1.6 kg (3.6 lbs.)

Cordless Nibbler
DJN161

18V



Capacity	Steel up to 400 N/mm ² : 1.6 mm Steel up to 600 N/mm ² : 1.2 mm Aluminum up to 200 N/mm ² : 2.5 mm
Min. cutting radius	Inside edge: 45 mm (1-3/4") Outside edge: 50 mm (2")
Strokes per minute	1,900 min ⁻¹
Dimensions (L x W x H)	313 x 78 x 189 mm (12-3/8 x 3-1/16 x 7-7/16")
Net weight	1.9 - 2.3 kg (4.3 - 5 lbs.)

LXT

Cement Shear
JS8000

Continuous rating Input	570W
Capacity	Max cutting: 8 mm (5/16")
Strokes per minute	0 - 2,500 min ⁻¹
Dimensions (L x W x H)	346 x 70 x 223 mm (13-5/8 x 2-3/4 x 8-3/4")
Net weight	2.2 kg (4.8 lbs.)

Metal Shear
JS1000

Continuous rating Input	380W
Capacity	Steel up to 400 N/mm ² : 1.0 mm Steel up to 600 N/mm ² : 0.7 mm Steel up to 800 N/mm ² : 0.5 mm Aluminum up to 200 N/mm ² : 2.5 mm
Min. cutting radius	30 mm (1-3/16")
Strokes per minute	4,500 min ⁻¹
Dimensions (L x W x H)	322 x 70 x 78 mm (12-5/8 x 2-3/4 x 3-1/16")
Net weight	1.4 kg (3.2 lbs.)

Metal Shear
JS3201

Continuous rating Input	710W
Capacity	Steel up to 400 N/mm ² : 3.2 mm Steel up to 600 N/mm ² : 2.5 mm Steel up to 800 N/mm ² : 1.5 mm Aluminum up to 200 N/mm ² : 4.0 mm
Min. cutting radius	50 mm (2")
Strokes per minute	1,600 min ⁻¹
Dimensions (L x W x H)	213 x 90 x 239 mm (8-3/8 x 3-1/2 x 9-3/8")
Net weight	3.4 kg (7.5 lbs.)

Nibbler
JN3201

Continuous rating Input	710W
Capacity	Steel up to 400 N/mm ² : 3.2 mm Steel up to 600 N/mm ² : 2.5 mm Steel up to 800 N/mm ² : 1.0 mm Aluminum up to 200 N/mm ² : 3.5 mm
Min. cutting radius	Outside edge: 128 mm (5-1/16") Inside edge: 120 mm (4-3/4")
Strokes per minute	1,300 min ⁻¹
Dimensions (L x W x H)	225 x 90 x 254 mm (8-7/8 x -1/2 x 10")
Net weight	3.4 kg (7.4 lbs.)



Cutting

Cordless Cable Cutter DTC100

18V

new



Max blade opening width 50 mm (2")
 Max cable cutting capacity 600V-CV: 500mm² single-core (38mm (1-1/2))
 6600V-CV: 500mm² single-core (45mm (1-3/4))
 600V-IV: 500mm² single-core (35mm (1-3/8))
 600V-VVR: 150mm² triple-core (47mm (1-7/8))

Dimensions (L x W x H) w/ BL1830B / BL1840B / BL1850B / BL1860B: 116 x 197 x 363 mm (4-9/16 x 7-3/4 x 14-1/4")

Net weight 2.9 kg (6.4 lbs.)



Cordless Cable Cutter DTC101

18V

new



Max blade opening width 50 mm (2")
 Max cable cutting capacity 600V-CV: 500mm² single-core (38mm (1-1/2))
 6600V-CV: 500mm² single-core (45mm (1-3/4))
 600V-IV: 500mm² single-core (35mm (1-3/8))
 600V-VVR: 150mm² triple-core (47mm (1-7/8))

Dimensions (L x W x H) w/ BL1830B / BL1840B / BL1850B / BL1860B: 116 x 190 x 430 mm (4-9/16 x 7-1/2 x 17")

Net weight 3.6 kg (7.9 lbs.)



Cordless Cable Cutter DTC102

18V

new



Max blade opening width 65 mm (2-9/16")
 Max cable cutting capacity Non-ferrous materials only (Al or Cu): 65 mm (2-9/16")

Dimensions (L x W x H) w/ BL1830B / BL1840B / BL1850B / BL1860B: 116 x 240 x 401 mm (4-9/16 x 9-1/2 x 15-3/4")

Net weight 3.5 kg (7.7 lbs.)



Cordless Cable Cutter DTC103

18V

new



Max blade opening width 54 mm (2-1/8")
 Max cable cutting capacity ACSR: Al 550mm² / ST 70mm²

Dimensions (L x W x H) w/ BL1830B / BL1840B / BL1850B / BL1860B: 116 x 240 x 401 mm (4-9/16 x 9-1/2 x 15-3/4")

Net weight 5.5 kg (12.1 lbs.)



Cutting

Cordless Multi Tool TM001G

40V max

new



Oscillation angle	3.6°
Oscillations per minute	10,000 - 20,000 min ⁻¹
Circumference of grip portion	169 mm (6-5/8")
Dimensions (L x W x H)	326 x 91.5 x 123 mm (12-7/8 x 3-5/8 x 4-7/8")
Net weight	2.1 - 3.3 kg (4.6 - 7.3 lbs.)

XGT BL MOTOR AVT XPT



Cordless Multi Tool DTM52

18V



Oscillation angle	3.6°
Oscillations per minute	10,000 - 20,000 min ⁻¹
Circumference of grip portion	169 mm (6-5/8")
Dimensions (L x W x H)	w/ BL1830B / BL1840B / BL1850B / BL1860B: 322 x 95 x 126 mm (12-5/8 x 3-3/4 x 5")
Net weight	1.7 - 2.0 kg (3.7 - 4.4 lbs.)

LXT BL MOTOR AVT XPT



Cordless Multi Tool DTM51

18V



Oscillation angle	3.2°
Oscillations per minute	6,000 - 20,000 min ⁻¹
Dimensions (L x W x H)	340 x 80 x 122 mm (13-3/8 x 3-1/8 x 4-13/16")
Net weight	2 - 2.4 kg (4.4 - 5.3 lbs.)

LXT



Cordless Multi Tool DTM50

18V



Oscillations per minute	6,000 - 20,000 min ⁻¹
Dimensions (L x W x H)	307 x 80 x 122 mm (12-1/4 x 3-1/8 x 4-13/16")
Net weight	1.8 - 2.2 kg (3.9 - 4.8 lbs.)

LXT



Cordless Multi Tool TM30D

12V max



Oscillation angle	3.2°
Oscillations per minute	6,000 - 20,000 min ⁻¹
Dimensions (L x W x H)	277 x 65 x 98 mm (10-7/8 x 2-9/16 x 3-7/8")
Net weight	1.1 - 1.3 kg (2.3 - 2.9 lbs.)

CXT



Multi Tool TM3010C



Continuous rating Input	320W
Strokes per minute	6,000 - 20,000 min ⁻¹
Dimensions (L x W x H)	283 x 68 x 87 mm (11-1/8 x 2-11/16 x 3-7/16")
Net weight	1.6 - 1.7 kg (3.7 - 3.9 lbs.)



Multi Tool TM3000C





















Continuous rating Input	320W
Strokes per minute	6,000 - 20,000 min ⁻¹
Dimensions (L x W x H)	275 x 64 x 92 mm (10-7/8 x 2-1/2 x 3-5/8")
Net weight	1.4 - 1.5 kg (3.2 - 3.3 lbs.)



PRODUCTS

Sawing



-  Double Insulation
-  Variable Speed
-  Brake
-  Anti-restart function
-  Mechanical 2-Speed
-  Electronic 2-Speed
-  Torque Limiter
-  Constant Speed
-  Soft Start
-  Bevel Cutting 45 left
-  Bevel Cutting 45 LR
-  Bevel Cutting L45 R5
-  Orbital Cutting
-  Bayonet Shank Jig Saw Blade
-  Laser Marker
-  Dust Collection
-  Toolless blade change
-  Built-in Job Light
-  Carrying Case

Sawing

Cordless Slide Compound Miter Saw
LS003G

40V max



Wheel diameter	305 mm (12")
No load speed	3,600 min ⁻¹
Bevel angle	Left: 48° / Right: 48°
Miter angle	Left: 60° / Right: 60°
Max cutting capacity	92 x 382 mm (3-5/8 x 15")
(Bevel 0° / Miter 0°)	107 x 363 mm (4-1/4 x 14-1/4")
Max cutting capacity	61 x 268 mm (2-3/8 x 10-1/2")
(Bevel 45°L / Miter 45°LR)	71 x 255 mm (2-13/16 x 10")
Dimensions (L x W x H)	898 x 690 x 725 mm
(35-1/4 x 27-1/4 x 28-1/2")	
Net weight	30.5 - 31.1 kg (67.2 - 68.6 lbs.)

XGT MOTOR DXT AWS

Cordless Slide Compound Miter Saw
LS002G

40V max



Wheel diameter	216 mm (8-1/2")
No load speed	4,800 min ⁻¹
Bevel angle	Left: 48° / Right: 48°
Miter angle	Left: 60° / Right: 60°
Max cutting capacity	0° Miter: 70 x 312 mm (2-3/4 x 12-1/4")
45° Miter, L/R:	70 x 220 mm
(2-3/4 x 8-5/8")	
Max cutting capacity	70 x 312 mm (2-3/4 x 12-1/4")
(Bevel 0° / Miter 0°)	
Max cutting capacity	50 x 220 mm (2 x 8-5/8")
(Bevel 45°L / Miter 45°LR)	
Dimensions (L x W x H)	702 x 551 x 557 mm
(27-5/8 x 21-3/4 x 22")	
Net weight	16.4 - 17.0 kg (36.2 - 37.6 lbs.)

XGT MOTOR DXT AWS

Cordless Slide Compound Miter Saw
LS004G

40V max



Wheel diameter	255 - 260 mm (10 - 10-1/4")
No load speed	3,600 min ⁻¹
Bevel angle	Left: 48° / Right: 48°
Miter angle	Left: 60° / Right: 60°
Max cutting capacity	0° Miter: 91 x 279 mm (3-5/8 x 11")
45° Miter, L/R:	91 x 197 mm
(3-5/8 x 7-3/4")	
Max cutting capacity	68 x 310 mm (2-11/16 x 12-1/4")
(Bevel 0° / Miter 0°)	91 x 279 mm (3-5/8 x 11")
Max cutting capacity	42 x 218 mm (1-5/8 x 8-5/8")
(Bevel 45°L / Miter 45°LR)	58 x 197 mm (2-1/4 x 7-3/4")
Dimensions (L x W x H)	805 x 644 x 660 mm
(31-3/4 x 25-3/8 x 26")	
Net weight	26.6 - 27.2 kg (58.6 - 60.0 lbs.)

XGT MOTOR DXT AWS

Cordless Slide Compound Miter Saw
DLS212

18V x2



Wheel diameter	305 mm (12")
No load speed	4,400 min ⁻¹
Bevel angle	Left: 48° / Right: 48°
Miter angle	Left: 60° / Right: 60°
Max cutting capacity	0° Miter: 107 x 363 x 92 x 382 mm
(4-1/4 x 14-1/4 x 3-5/8 x 15")	
45° Miter, L/R:	107 x 255 x 92 x 268 mm
(4-1/4 x 10 x 3-5/8 x 10-1/2")	
Dimensions (L x W x H)	898 x 690 x 725 mm
(35-1/4 x 27-1/4 x 28-1/2")	
Net weight	30.7 - 31.3 kg (67.6 - 69.1 lbs.)

LXT MOTOR ADT DXT

Cordless Slide Compound Miter Saw
DLS211

18V x2



Wheel diameter	305 mm (12")
No load speed	4,400 min ⁻¹
Bevel angle	Left: 48° / Right: 48°
Miter angle	Left: 60° / Right: 60°
Max cutting capacity	0° Miter: 107 x 363 x 92 x 382 mm
(4-1/4 x 14-1/4 x 3-5/8 x 15")	
45° Miter, L/R:	107 x 255 x 92 x 268 mm
(4-1/4 x 10 x 3-5/8 x 10-1/2")	
Dimensions (L x W x H)	898 x 690 x 725 mm
(35-1/4 x 27-1/4 x 28-1/2")	
Net weight	30.7 - 31.3 kg (67.6 - 69.1 lbs.)

LXT MOTOR ADT DXT AWS

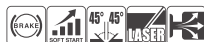
Cordless Slide Compound Miter Saw
DLS112

18V x2



Wheel diameter	255 - 260 mm (10 - 10-1/4")
No load speed	4,400 min ⁻¹
Bevel angle	Left: 48° / Right: 48°
Miter angle	Left: 60° / Right: 60°
Max cutting capacity	0° Miter: 91 x 279 x 68 x 310 mm
(3-5/8 x 11")	
45° Miter, L/R:	91 x 197 x 68 x 218 mm
(3-5/8 x 7-3/4")	
Dimensions (L x W x H)	805 x 644 x 660 mm
(31-3/4 x 25-3/8 x 26")	
Net weight	26.6 - 27.3 kg (58.6 - 60.2 lbs.)

LXT MOTOR ADT DXT

Cordless Slide Compound Miter Saw
DLS111

18V x2



Wheel diameter	255 - 260 mm (10 - 10-1/4")
No load speed	4,400 min ⁻¹
Bevel angle	Left: 48° / Right: 48°
Miter angle	Left: 60° / Right: 60°
Max cutting capacity	0° Miter: 91 x 279 x 68 x 310 mm
(3-5/8 x 11 x 2-11/16 x 12-1/4")	
45° Miter, L/R:	91 x 197 x 68 x 218 mm
(3-5/8 x 7-3/4 x 2-11/16 x 8-5/8")	
Dimensions (L x W x H)	805 x 644 x 660 mm
(31-3/4 x 25-3/8 x 26")	
Net weight	26.6 - 27.3 kg (58.6 - 60.2 lbs.)

LXT MOTOR ADT DXT AWS

Cordless Slide Compound Miter Saw
DLS110

18V x2



Wheel diameter	255 - 260 mm (10 - 10-1/4")
No load speed	4,400 min ⁻¹
Bevel angle	Left: 48° / Right: 48°
Miter angle	Left: 60° / Right: 60°
Max cutting capacity	0° Miter: 91 x 279 x 68 x 310 mm
(3-5/8 x 11")	
45° Miter, L/R:	91 x 197 x 68 x 218 mm
(3-5/8 x 7-3/4")	
Dimensions (L x W x H)	805 x 644 x 660 mm
(31-3/4 x 25-3/8 x 26")	
Net weight	26.6 - 27.3 kg (58.6 - 60.2 lbs.)

LXT MOTOR ADT DXT

Cordless Slide Compound Miter Saw
DLS714

18V x2



Wheel diameter	190 mm (7-1/2")
No load speed	5,700 min ⁻¹
Bevel angle	Left: 45° / Right: 5°
Miter angle	Left: 47° / Right: 57°
Max cutting capacity	0°: 52 x 300 mm (2-1/16 x 11-3/4")
Dimensions (L x W x H)	655 x 430 x 445 mm
(25-3/4 x 17 x 17-1/2")	
Net weight	12.6 kg (27.8 lbs.)

LXT MOTOR ADT

Cordless Slide Compound Miter Saw
DLS713

18V



Wheel diameter	190 mm (7-1/2")
No load speed	2,200 min ⁻¹
Bevel angle	Left: 45° / Right: 5°
Miter angle	Left: 47° / Right: 57°
Max cutting capacity	0°: 52 x 300 mm (2-1/16 x 11-3/4")
Dimensions (L x W x H)	655 x 430 x 454 mm
(25-3/4 x 17 x 17-7/8")	
Net weight	12.1 kg (26.7 lbs.)

LXT



Cordless Compound Miter Saw DLS600

18V



Wheel diameter	155 - 165 mm (6-1/8 - 6-1/2")
Hole diameter	15.88/ 20 mm (5/8/ 13/16")
No load speed	5,000 min ⁻¹
Bevel angle	Left: 46° / Right: 46°
Miter angle	Left: 52° / Right: 52°
Max cutting capacity	0° Miter: 46 x 92 mm (1-13/16 x 3-5/8") 45° Miter, L/R: 46 x 65 mm (1-13/16 x 2-9/16")
Dimensions (L x W x H)	340 x 400 x 440 mm (13-3/8 x 15-3/4 x 17-1/4")
Net weight	6.3 - 6.6 kg (13.9 - 14.6 lbs.)

LXT MOTOR ADT DXT



Slide Compound Miter Saw LS1219L



Continuous rating Input	1,800W
Wheel diameter	305 mm (12")
No load speed	3,200 min ⁻¹
Bevel angle	Left: 48° / Right: 48°
Miter angle	Left: 60° / Right: 60°
Max cutting capacity	0° Miter: 107 x 363 mm (4-1/4 x 14-1/4") 45° Miter, L/R: 107 x 255 mm (4-1/4 x 10")
Dimensions (L x W x H)	898 x 664 x 725 mm (35-1/4 x 26-1/8 x 28-1/2")
Net weight	29.5 kg (65 lbs.)

DXT



Slide Compound Miter Saw LS1219



Continuous rating Input	1,800W
Wheel diameter	305 mm (12")
No load speed	3,200 min ⁻¹
Bevel angle	Left: 48° / Right: 48°
Miter angle	Left: 60° / Right: 60°
Max cutting capacity	0° Miter: 107 x 363 mm (4-1/4 x 14-1/4") 45° Miter, L/R: 107 x 255 mm (4-1/4 x 10")
Dimensions (L x W x H)	898 x 664 x 725 mm (35-1/4 x 26-1/8 x 28-1/2")
Net weight	29.3 kg (64.6 lbs.)

DXT



Slide Compound Miter Saw LS1019L



Continuous rating Input	1,510W
Wheel diameter	255 - 260 mm (10 - 10-1/4")
No load speed	3,200 min ⁻¹
Bevel angle	Left: 48° / Right: 48°
Miter angle	Left: 60° / Right: 60°
Max cutting capacity	0° Miter: 68 x 310 mm (2-11/16 x 12-1/4") 45° Miter, L/R: 91 x 197 mm (3-5/8 x 7-3/4")
Dimensions (L x W x H)	805 x 644 x 660 mm (31-3/4 x 25-3/8 x 26")
Net weight	26.3 kg (57.9 lbs.)

DXT



Slide Compound Miter Saw LS1019



Continuous rating Input	1,510W
Wheel diameter	255 - 260 mm (10 - 10-1/4")
No load speed	3,200 min ⁻¹
Bevel angle	Left: 48° / Right: 48°
Miter angle	Left: 60° / Right: 60°
Max cutting capacity	0° Miter: 68 x 310 mm (2-11/16 x 12-1/4") 45° Miter, L/R: 91 x 197 mm (3-5/8 x 7-3/4")
Dimensions (L x W x H)	805 x 644 x 660 mm (31-3/4 x 25-3/8 x 26")
Net weight	26.1 kg (57.6 lbs.)

DXT



Slide Compound Miter Saw LS1110F



Continuous rating Input	1,450W
Wheel diameter	260 mm (10-1/4")
No load speed	4,500 min ⁻¹
Bevel angle	Left: 47° / Right: 2°
Miter angle	Left: 47° / Right: 47°
Max cutting capacity	Bevel 0° / Miter 0°: 91 x 310mm (3-5/8 x 12-1/4") Bevel 0° / Miter 45°LR: 91 x 220mm (3-5/8 x 8-5/8")
Dimensions (L x W x H)	745 x 497 x 565 mm (29-1/4 x 19-1/2 x 22-1/4")
Net weight	16.4 kg (36.2 lbs.)



Slide Compound Saw LS1018L



Continuous rating Input	1,430W
Wheel diameter	255 - 260 mm (10 - 10-1/4")
Blade body thickness	1.5 - 3.2 mm
No load speed	4,300 min ⁻¹
Bevel angle	Left: 45° / Right: 45°
Miter angle	Left: 47° / Right: 60°
Max cutting capacity	0°: 91 x 305 mm (3-5/8 x 12") 45°: 91 x 215 mm (3-5/8 x 8-1/2")
Dimensions (L x W x H)	825 x 536 x 633 mm (32-1/2 x 21-1/8 x 25")
Net weight	20.6 kg (45.4 lbs.)



Slide Compound Saw LS1017L



Continuous rating Input	1,430W
Wheel diameter	255 - 260 mm (10 - 10-1/4")
Blade body thickness	1.5 - 3.2 mm
No load speed	4,200 min ⁻¹
Bevel angle	Left: 45° / Right: 5°
Miter angle	Left: 47° / Right: 60°
Max cutting capacity	0°: 91 x 305 mm (3-5/8 x 12") 45°: 91 x 215 mm (3-5/8 x 8-1/2")
Dimensions (L x W x H)	825 x 536 x 581 mm (32-1/2 x 21-1/8 x 22-7/8")
Net weight	19.5 kg (43 lbs.)



Slide Compound Miter Saw LS0815FL



Continuous rating Input	1,400W
Wheel diameter	216 mm (8-1/2")
No load speed	5,000 min ⁻¹
Bevel angle	Left: 48° / Right: 5°
Miter angle	Left: 50° / Right: 60°
Max cutting capacity	0° Miter: 65 x 305 mm (2-9/16 x 12") 45° Miter, L/R: 65 x 215 mm (2-9/16 x 8-1/2")
Dimensions (L x W x H)	755 x 450 x 488 mm (29-3/4 x 17-3/4 x 19-1/4")
Net weight	14.1 kg (31.1 lbs.)

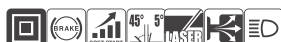

Slide Compound Miter Saw LS0815F



Continuous rating Input	1,400W
Wheel diameter	216 mm (8-1/2")
No load speed	5,000 min ⁻¹
Bevel angle	Left: 48° / Right: 5°
Miter angle	Left: 50° / Right: 60°
Max cutting capacity	0° Miter: 65 x 305 mm (2-9/16 x 12") 45° Miter, L/R: 65 x 215 mm (2-9/16 x 8-1/2")
Dimensions (L x W x H)	755 x 450 x 488 mm (29-3/4 x 17-3/4 x 19-1/4")
Net weight	14.1 kg (31.1 lbs.)



Sawing

Slide Compound Miter Saw
LS0816F

Continuous rating Input	1,200W
Wheel diameter	216 mm (8-1/2")
Hole diameter	30 mm (1-3/16")
No load speed	5,000 min ⁻¹
Bevel angle	Left: 47° / Right: 2°
Miter angle	Left: 47° / Right: 47°
Dimensions (L x W x H)	705 x 476 x 521 mm (27-3/4 x 18-3/4 x 20-1/2")
Net weight	13.9 kg (30.6 lbs.)

Slide Compound Saw
LS0714FL

Continuous rating Input	1,010W
Wheel diameter	190 mm (7-1/2")
Blade body thickness	1.3 - 2.0 mm
No load speed	6,000 min ⁻¹
Bevel angle	Left: 45° / Right: 5°
Miter angle	Left: 47° / Right: 57°
Max cutting capacity	0°: 52 x 300 mm (2-1/16 x 11-3/4") 45°: 52 x 212 mm (2-1/16 x 8-3/8")
Dimensions (L x W x H)	670 x 430 x 458 mm (26-3/8 x 17 x 18")
Net weight	13.7 kg (30.2 lbs.)

Slide Compound Saw
LS0714L

Continuous rating Input	1,010W
Wheel diameter	190 mm (7-1/2")
Blade body thickness	1.3 - 2.0 mm
No load speed	6,000 min ⁻¹
Bevel angle	Left: 45° / Right: 5°
Miter angle	Left: 47° / Right: 57°
Max cutting capacity	0°: 52 x 300 mm (2-1/16 x 11-3/4") 45°: 52 x 212 mm (2-1/16 x 8-3/8")
Dimensions (L x W x H)	670 x 430 x 458 mm (26-3/8 x 17 x 18")
Net weight	13.5 kg (29.8 lbs.)

Slide Compound Saw
LS0714F

Continuous rating Input	1,010W
Wheel diameter	190 mm (7-1/2")
Blade body thickness	1.3 - 2.0 mm
No load speed	6,000 min ⁻¹
Bevel angle	Left: 45° / Right: 5°
Miter angle	Left: 47° / Right: 57°
Max cutting capacity	0°: 52 x 300 mm (2-1/16 x 11-3/4") 45°: 52 x 212 mm (2-1/16 x 8-3/8")
Dimensions (L x W x H)	670 x 430 x 458 mm (26-3/8 x 17 x 18")
Net weight	13.4 kg (29.5 lbs.)

Slide Compound Saw
LS0714

Continuous rating Input	1,010W
Wheel diameter	190 mm (7-1/2")
Blade body thickness	1.3 - 2.0 mm
No load speed	6,000 min ⁻¹
Bevel angle	Left: 45° / Right: 5°
Miter angle	Left: 47° / Right: 57°
Max cutting capacity	0°: 52 x 300 mm (2-1/16 x 11-3/4") 45°: 52 x 212 mm (2-1/16 x 8-3/8")
Dimensions (L x W x H)	670 x 430 x 458 mm (26-3/8 x 17 x 18")
Net weight	13.1 kg (28.9 lbs.)

Compound Miter Saw
LS1221

Continuous rating Input	1,650W
Wheel diameter	305 mm (12")
Hole diameter	25.4/30 mm (1/1-3/16")
No load speed	4,000 min ⁻¹
Bevel angle	Left: 45°
Miter angle	Left: 48° / Right: 48°
Max cutting capacity	0°: 98 x 153 mm (3-7/8 x 6") 45°: 70 x 149 mm (2-3/4 x 5-7/8")
Dimensions (L x W x H)	674 x 610 x 607 mm (26-1/2 x 24 x 23-7/8")
Net weight	16.8 kg (37 lbs.)

Compound Miter Saw
LS1040F

Continuous rating Input	1,650W
Wheel diameter	255 - 260 mm (10/10-1/4")
Hole diameter	15.88/25/25.4/30 mm (5/8/1/1-3/16")
No load speed	4,600 min ⁻¹
Bevel angle	Left: 45°
Max cutting capacity	0°: 90.5 x 95 mm (3-9/16 x 3-3/4") 45°: 90.5 x 67 mm (3-9/16 x 2-5/8")
Dimensions (L x W x H)	530 x 476 x 532 mm (20-7/8 x 18-3/8 x 21")
Net weight	12.6 kg (27.8 lbs.)

Compound Miter Saw
LS1040

Continuous rating Input	1,650W
Wheel diameter	255 - 260 mm (10/10-1/4")
Hole diameter	15.88/25/25.4/30 mm (5/8/1/1-3/16")
No load speed	4,600 min ⁻¹
Bevel angle	Left: 45°
Max cutting capacity	0°: 90.5 x 95 mm (3-9/16 x 3-3/4") 45°: 90.5 x 67 mm (3-9/16 x 2-5/8")
Dimensions (L x W x H)	530 x 476 x 532 mm (20-7/8 x 18-3/8 x 21")
Net weight	12.4 kg (27.3 lbs.)

Compound Miter Saw
LS1045

Continuous rating Input	1,650W
Wheel diameter	255 - 260 mm (10/10-1/4")
Hole diameter	15.88/25/25.4/30 mm (5/8/1/1-3/16")
No load speed	4,600 min ⁻¹
Bevel angle	Left: 45°
Miter angle	Left: 45° / Right: 52°
Max cutting capacity	0°: 90.5 x 95 mm (3-9/16 x 3-3/4") 45°: 90.5 x 67 mm (3-9/16 x 2-5/8")
Dimensions (L x W x H)	530 x 476 x 532 mm (20-7/8 x 18-3/4 x 21")
Net weight	19.1 kg (42 lbs.)

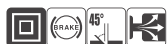
Miter Saw
LS1440

Continuous rating Input	1,380W
Wheel diameter	355 mm (14")
Hole diameter	25, 25.4 mm (1")
No load speed	3,200 min ⁻¹
Max cutting capacity	0°: 122 x 152 mm (4-13/16 x 6") 45°: 122 x 115 mm (4-13/16 x 4-1/2")
Dimensions (L x W x H)	530 x 596 x 435 mm (20-7/8 x 23-1/2 x 17-1/8")
Net weight	34.2 kg (75.4 lbs.)



Miter Saw LS1030N



Continuous rating Input	1,650W
Wheel diameter	255 / 260 mm (10")
Hole diameter	15.88, 25.0, 25.4, 30.0 mm (5/8, 1, 1-3/16")
No load speed	4,600 min ⁻¹
Max cutting capacity	0°: 90.5 x 95 mm (3-9/16 x 3-3/4") 45°: 90.5 x 67 mm (3-9/16 x 2-5/8")
Dimensions (L x W x H)	530 x 476 x 532 mm (20-7/8 x 18-3/4 x 21")
Net weight	12.1 kg (26.7 lbs.)



Table Top Miter Saw LH1201FL



Continuous rating Input	1,650W
Wheel diameter	305 mm (12")
Hole diameter	25.4/30 mm (1/ 1-3/16")
No load speed	3,800 min ⁻¹
Bevel angle	45° L
Miter angle	Left: 47° / Right: 52°
Max cutting capacity	0°: 62, 95 x 200, 155 mm (2-7/16, 3-3/4 x 7-7/8, 6-1/8") 45° Miter, L/R: 62 x 135 x 95 x 110 mm (2-7/16 x 5-5/16 x 3-3/4 x 4-5/16")
Dimensions (L x W x H)	610 x 535 x 692 mm (24 x 21 x 27-1/4")
Net weight	20.9 kg (46.1 lbs.)



Table Top Miter Saw LH1040F



Continuous rating Input	1,650W
Wheel diameter	255/ 260 mm (10/ 10-1/4")
Hole diameter	15.88/ 25.4/ 30 mm (5/8/ 1/ 1-3/16")
No load speed	4,800 min ⁻¹
Max cutting capacity	0°: 93 x 95 mm (3-5/8 x 3-3/4") 45°: 53 x 95 mm (2-1/6 x 3-3/4")
Dimensions (L x W x H)	530 x 476 x 535 mm (20-7/8 x 18-3/4 x 21")
Net weight	14.3 kg (31.5 lbs.)



Table Top Miter Saw LH1040



Continuous rating Input	1,650W
Wheel diameter	255/ 260 mm (10/ 10-1/4")
Hole diameter	15.88/ 25.4/ 30 mm (5/8/ 1/ 1-3/16")
No load speed	4,800 min ⁻¹
Max cutting capacity	0°: 93 x 95 mm (3-5/8 x 3-3/4") 45°: 53 x 95 mm (2-1/6 x 3-3/4")
Dimensions (L x W x H)	530 x 476 x 535 mm (20-7/8 x 18-3/4 x 21")
Net weight	14.3 kg (31.5 lbs.)



Flip Over Saw LF1000



Continuous rating Input	1,650W
Wheel diameter	260 mm (10-1/4")
Hole diameter	30/ 25.4 mm (1-3/16/ 1")
No load speed	2,700 min ⁻¹
Max cutting capacity	0°: 20, 68 x 155, 210 mm (13/16, 2-11/16 x 6-1/8, 8-1/4") 45°: 50 x 150 mm (2 x 5-7/8")
Dimensions (L x W x H)	Miter saw: 660 x 650 x 1,220 mm (26 x 25-1/2 x 48") Table saw: 660 x 650 x 1,060 mm (26 x 25-1/2 x 41-3/4")
Net weight	36 kg (79.4 lbs.)



Table Saw 2712



Wheel diameter	315 mm (12-3/8")
No load speed	50 Hz: 2,950 min ⁻¹ 60 Hz: 3,400 min ⁻¹
Bevel capacity	0 - 45°
Max cutting capacity	0°: 85 mm (3-3/8") 45°: 58 mm (2-1/4")
Dimensions (L x W x H)	1,670 x 700 x 810 mm (65-3/4 x 27-1/2 x 32")
Net weight	54 kg (118.9 lbs.)



Table Saw 2704N



Continuous rating Input	1,650W
Wheel diameter	260 mm (10-1/4")
No load speed	5,200 min ⁻¹
Bevel capacity	-0.5 - 50°
Max cutting capacity	0°: 93 mm (3-5/8") 45°: 64 mm (2-1/2")
Dimensions (L x W x H)	715-1,095 x 753-1,066 x 483 mm (28-1/8"-43" x 29-5/8"-42" x 19")
Net weight	35.2 - 37 kg (77.6 - 81.5 lbs.)



Table Saw 2704



Continuous rating Input	1,650W
Wheel diameter	260 mm (10-1/4")
No load speed	4,800 min ⁻¹
Bevel capacity	-0.5 - 45.5°
Max cutting capacity	0°: 93 mm (3-5/8") 45°: 64 mm (2-1/2")
Dimensions (L x W x H)	665 x 766 x 344 mm (26-1/4 x 30-1/4 x 13-1/2")
Net weight	35.6 - 37.3 kg (78.5 - 82.3 lbs.)



Table Saw MLT100N



Continuous rating Input	1,500W
Wheel diameter	260 mm (10-1/4")
No load speed	4,300 min ⁻¹
Bevel capacity	0 - 45°
Max cutting capacity	0°: 93 mm (3-5/8") 45°: 64 mm (2-1/2")
Max cutting width	on the right side of blade: 630 mm (24-3/4")
Dimensions (L x W x H)	726 x 984 x 473 mm (28-1/2 x 38-3/4 x 18-5/8")
Net weight	34.8 - 35.1 kg (76.7 - 77.4 lbs.)



Table Saw 2703



Continuous rating Input	1,650W
Wheel diameter	255 mm (10")
No load speed	4,600 min ⁻¹
Max cutting capacity	0°: 91 mm (3-9/16") 45°: 63 mm (2-1/2")
Dimensions (L x W x H)	560 x 686 x 308 mm (22 x 27 x 12-1/8")
Net weight	17.8 - 18.9 kg (39.2 - 41.7 lbs.)



Sawing

Cordless Circular Saw
HS013G

40V max

new



No load speed	2,100 min ⁻¹
Saw blade	Diameter: 415 mm (16-5/16")
Max cutting capacity	0°: 158 mm (6-1/4") 45°: 106 mm (4-3/16")
Dimensions (L x W x H)	606 x 233 x 476 mm (23-7/8 x 9-1/8 x 18-3/4")
Net weight	11.0 - 12.0 kg (24.3 - 26.5 lbs.)

XGT MOTOR BL AWS XPT

Cordless Circular Saw
HS010G

40V max



Wheel diameter	235 mm (9-1/4")
Hole diameter	25 / 25.4 / 30 mm (1 / 1 / 1-3/16")
No load speed	4,000 min ⁻¹
Max cutting capacity	0°: 85 mm (3-3/8") 45°: 61 mm (2-3/8") 60°: 41 mm (1-5/8")
Dimensions (L x W x H)	430 x 224 x 316 mm (17 x 8-7/8 x 12-1/2")
Net weight	5.5 - 6.1 kg (12.1 - 13.4 lbs.)

XGT MOTOR BL AWS XPT

Cordless Circular Saw
HS003G

40V max



Wheel diameter	185 - 190 mm (7-1/4 - 7-1/2")
Hole diameter	15.88 / 19 / 20 / 30 mm (5/8 / 3/4 / 13/16 / 1-3/16")
No load speed	6,000 min ⁻¹
Max cutting capacity	0°: 66 mm (2-5/8") 45°: 45.5 mm (1-13/16") 56°: 35.5 / 34 mm (1-3/8 / 1-5/16") w/ BL4040: 331 x 200 x 290 mm (13 x 7-7/8 x 11-3/8")
Dimensions (L x W x H)	
Net weight	4.1 - 4.4 kg (9.0 - 9.7 lbs.)

XGT MOTOR BL ADT AWS XPT

Cordless Circular Saw
HS012G

40V max



Wheel diameter	165 mm (6-1/2")
Hole diameter	20 mm (13/16")
No load speed	5,200 min ⁻¹
Max cutting capacity	0°: 57 mm (2-1/4") 45°: 41 mm (1-5/8")
Dimensions (L x W x H)	w/ BL4080F: 406 x 157 x 246 mm (16 x 6-3/16 x 9-11/16")
Net weight	3.2 - 4.4 kg (7.1 - 9.7 lbs.)

XGT MOTOR BL AWS XPT

Cordless Circular Saw
DHS901

18V x2



Wheel diameter	235 mm (9-1/4")
Hole diameter	15.88 / 25 / 25.4 / 30 mm (5/8 / 1 / 1-3/16")
No load speed	4,500 min ⁻¹
Max cutting capacity	0°: 85 mm (3-3/8") 45°: 61 mm (2-3/8") 60°: 41 mm (1-5/8")
Dimensions (L x W x H)	430 x 224 x 316 mm (17 x 8-7/8 x 12-1/2")
Net weight	5.8 - 6.4 kg (12.8 - 14.1 lbs.)

LXI MOTOR BL ADT AWS XPT

Cordless Circular Saw
HS011G

40V max



No load speed	3,500 min ⁻¹
Wheel diameter	255 - 270 mm (10 - 10-5/8")
Hole diameter	15.88 / 25 / 25.4 / 30 mm (5/8 / 1 / 1-3/16")
Max cutting capacity	0°: 94 - 101 mm (3-11/16 - 4") 45°: 65 - 71 mm (2-9/16 - 2-13/16") 60°: 45 - 51 mm (1-3/4 - 2")
Dimensions (L x W x H)	w/ BL4080F: 453 x 214 x 336 mm (17-7/8 x 8-3/8 x 13-1/4")
Net weight	5.5 - 6.7 kg (12.1 - 14.8 lbs.)

XGT MOTOR BL AWS XPT

Cordless Circular Saw
HS009G

40V max



Wheel diameter	235 mm (9-1/4")
Hole diameter	15.88 / 25 / 25.4 / 30 mm (5/8 / 1 / 1-3/16")
No load speed	4,000 min ⁻¹
Max cutting capacity	0°: 85 mm (3-3/8") 45°: 61 mm (2-3/8") 60°: 44 mm (1-3/4")
Dimensions (L x W x H)	413 x 196 x 316 mm (16-1/4 x 7-3/4 x 12-1/2")
Net weight	5.1 - 5.7 kg (11.2 - 12.6 lbs.)

XGT MOTOR BL AWS XPT

Cordless Circular Saw
HS004G

40V max



Wheel diameter	185 - 190 mm (7-1/4 - 7-1/2")
Hole diameter	15.88 / 19 / 20 / 30 mm (5/8 / 3/4 / 13/16 / 1-3/16")
No load speed	6,000 min ⁻¹
Max cutting capacity	0°: 62.5 / 60 mm (2-7/16 / 2-3/8") 45°: 44.5 / 43 mm (1-3/4 / 1-11/16") 48°: 42 / 41 mm (1-5/8 / 1-5/8")
Dimensions (L x W x H)	w/ BL4040: 337 x 210 x 290 mm (13-1/4 x 8-1/4 x 11-3/8")
Net weight	4.4 - 4.7 kg (9.7 - 10.4 lbs.)

XGT MOTOR BL ADT AWS XPT

Cordless Circular Saw
DHS900

18V x2



Wheel diameter	235 mm (9-1/4")
Hole diameter	15.88 / 25 / 25.4 / 30 mm (5/8 / 1 / 1-3/16")
No load speed	4,500 min ⁻¹
Max cutting capacity	0°: 85 mm (3-3/8") 45°: 61 mm (2-3/8") 60°: 44 mm (1-3/4")
Dimensions (L x W x H)	413 x 196 x 316 mm (16-1/4 x 7-3/4 x 12-1/2")
Net weight	5.3 - 6.0 kg (11.7 - 13.2 lbs.)

LXI MOTOR BL ADT AWS XPT

Cordless Circular Saw
DHS783

18V x2



Wheel diameter	185 / 190 mm (7-1/2 / 7-1/4")
Hole diameter	15.88 / 19 / 20 / 20.6 / 25.4 / 30 mm (5/8 / 3/4 / 13/16 / 13/16 / 1-3/16")
No load speed	6,000 min ⁻¹
Max cutting capacity	0°: 62.5 / 60 mm (2-7/16 / 2-3/8") 45°: 44.5 / 43 mm (1-3/4 / 1-11/16") 48°: 42 / 41 mm (1-5/8 / 1-5/8")
Dimensions (L x W x H)	348 x 210 x 290 mm (13-3/4 x 8-1/4 x 11-3/8")
Net weight	4.5 - 5.1 kg (9.9 - 11.3 lbs.)

LXI MOTOR BL ADT AWS XPT



Cordless Circular Saw DHS782

18V x2



Wheel diameter	185/190 mm (7-1/2/ 7-1/4")
Hole diameter	15.88 / 19 / 20 / 20.6 / 30 mm (5/8 / 3/4 / 13/16 / 1-3/16")
No load speed	6,000 min ⁻¹
Max cutting capacity	0°: 62.5 / 60 mm (2-7/16 / 2-3/8") 45°: 44.5 / 43 mm (1-3/4 / 1-11/16") 48°: 42 / 41 mm (1-5/8 / 1-5/8")
Dimensions (L x W x H)	348 x 210 x 290 mm (13-3/4 x 8-1/4 x 11-3/8")
Net weight	4.5 - 5.1 kg (9.9 - 11.3 lbs.)

LXI MOTOR ADT XPT



Cordless Circular Saw DHS781

18V x2



Wheel diameter	185/190 mm (7-1/2/ 7-1/4")
Hole diameter	15.88 / 20 / 20.6 / 30 mm (5/8 / 13/16 / 13/16 / 1-3/16")
No load speed	6,000 min ⁻¹
Max cutting capacity	0°: 68.5 / 66 mm (2-11/16 / 2-5/8") 45°: 47.5 / 45.5 mm (1-7/8 / 1-13/16") 56°: 35.5 / 34 mm (1-3/8 / 1-5/16")
Dimensions (L x W x H)	342 x 200 x 290 mm (13-1/2 x 7-7/8 x 11-3/8")
Net weight	4.2 - 4.8 kg (9.3 - 10.7 lbs.)

LXI MOTOR ADT AWS XPT



Cordless Circular Saw DHS780

18V x2



Wheel diameter	185/190 mm (7-1/2/ 7-1/4")
Hole diameter	15.88 / 20 / 20.6 / 25.4 / 30 mm (5/8 / 3/4 / 13/16 / 1 / 1-3/16")
No load speed	6,000 min ⁻¹
Max cutting capacity	0°: 68.5 / 66 mm (2-11/16 / 2-5/8") 45°: 47.5 / 45.5 mm (1-7/8 / 1-13/16") 56°: 35.5 / 34 mm (1-3/8 / 1-5/16")
Dimensions (L x W x H)	342 x 200 x 290 mm (13-1/2 x 7-7/8 x 11-3/8")
Net weight	4.2 - 4.8 kg (9.3 - 10.7 lbs.)

LXI MOTOR ADT XPT



Cordless Circular Saw DHS710

18V x2



Wheel diameter	185/190 mm (7-1/2/ 7-1/4")
Hole diameter	15.88 / 19 / 20 / 25.4 mm (5/8 / 3/4 / 13/16 / 1")
No load speed	4,800 min ⁻¹
Max cutting capacity	0°: 68.5 / 66 mm (2-11/16 / 2-5/8") 45°: 49 / 47.5 mm (1-15/16 / 1-7/8") 50°: 44 / 42.5 mm (1-3/4 / 1-11/16")
Dimensions (L x W x H)	356 x 217 x 298 mm (14 x 8-1/2 x 11-3/4")
Net weight	3.9 - 4.6 kg (8.6 - 10.1 lbs.)

LXI



Cordless Circular Saw DHS661

18V



Wheel diameter	165 mm (6-1/2")
Hole diameter	15.88 / 19 / 20 / 25.4 / 30 mm (5/8 / 3/4 / 13/16 / 1 / 1-3/16")
No load speed	5,000 min ⁻¹
Max cutting capacity	0°: 57 mm (2-1/4") 45°: 41 mm (1-5/8") 50°: 37 mm (1-7/16")
Dimensions (L x W x H)	270 x 186 x 250 mm (10-5/8 x 7-3/8 x 9-7/8")
Net weight	2.9 - 3.2 kg (6.4 - 7.1 lbs.)

LXI MOTOR ADT AWS XPT



Cordless Circular Saw DHS660

18V



Wheel diameter	165 mm (6-1/2")
Hole diameter	15.88 / 19 / 20 / 30 mm (5/8 / 3/4 / 13/16 / 1")
No load speed	5,000 min ⁻¹
Max cutting capacity	0°: 57 mm (2-1/4") 45°: 41 mm (1-5/8") 50°: 37 mm (1-7/16")
Dimensions (L x W x H)	270 x 186 x 250 mm (10-5/8 x 7-3/8 x 9-7/8")
Net weight	2.9 - 3.2 kg (6.3 - 7.0 lbs.)

LXI MOTOR ADT XPT



Cordless Circular Saw DHS680

18V



Wheel diameter	165 mm (6-1/2")
Hole diameter	15.88 / 20 / 25.4 / 30 mm (5/8 / 13/16 / 1 / 1-3/16")
No load speed	5,000 min ⁻¹
Max cutting capacity	0°: 57 mm (2-1/4") 45°: 41 mm (1-5/8") 50°: 37 mm (1-7/16")
Dimensions (L x W x H)	350 x 170 x 238 mm (13-3/4 x 6-11/16 x 9-3/8")
Net weight	3 - 3.3 kg (6.6 - 7.3 lbs.)

LXI MOTOR ADT



Cordless Circular Saw DHS630

18V



Wheel diameter	165 mm (6-1/2")
Hole diameter	20 mm (13/16")
No load speed	3,100 min ⁻¹
Max cutting capacity	0°: 66 mm (2-5/8") 45°: 46 mm (1-13/16")
Dimensions (L x W x H)	346 x 220 x 247 mm (13-5/8 x 8-5/8 x 9-3/4")
Net weight	3 - 3.4 kg (6.6 - 7.5 lbs.)

LXI



Cordless Circular Saw DSS610

18V



Wheel diameter	165 mm (6-1/2")
Hole diameter	15.88 / 20 mm (5/8 / 13/16")
No load speed	3,700 min ⁻¹
Max cutting capacity	0°: 0 - 57 mm (0 - 2-1/4") 45°: 0 - 40 mm (0 - 1-9/16") 50°: 0 - 36 mm (0 - 1-7/16")
Dimensions (L x W x H)	347 x 202 x 228 mm (13-5/8 x 8 x 9")
Net weight	3 - 3.4 kg (6.7 - 7.5 lbs.)

LXI



Cordless Circular Saw DSS611

18V



Wheel diameter	165 mm (6-1/2")
Hole diameter	15.88 / 20 / 25.4 / 30 mm (5/8 / 13/16 / 1 / 1-3/16")
No load speed	3,700 min ⁻¹
Max cutting capacity	0°: 57 mm (2-1/4") 45°: 40 mm (1-9/16") 50°: 36 mm (1-7/16")
Dimensions (L x W x H)	347 x 202 x 228 mm (13-5/8 x 8 x 9")
Net weight	2.9 - 3.2 kg (6.4 - 7.1 lbs.)

LXI



Sawing

Cordless Circular Saw
DSS501

18V



Wheel diameter	136 mm (5-3/8")
Hole diameter	15.88 / 20 mm (5/8 / 13/16")
No load speed	3,600 min ⁻¹
Max cutting capacity	0°: 51 mm (2") 45°: 35 mm (1-3/8")
Dimensions (L x W x H)	364 x 183 x 201 mm (14-3/8 x 7-1/4 x 7-7/8")
Net weight	2.4 - 2.7 kg (5.3 - 6 lbs.)

LXT

Cordless Circular Saw
HS300D

10.8V



Wheel diameter	85 mm (3-3/8")
Hole diameter	15 / 20 mm (9/16 / 13/16")
No load speed	1,400 min ⁻¹
Max cutting capacity	0°: 25.5 mm (1") 45°: 16.5 mm (5/8")
Dimensions (L x W x H)	300 x 170 x 154 mm (11-3/4 x 6-11/16 x 6-1/16")
Net weight	1.5 kg (3.4 lbs.)

Cordless Rear Handle Saw
RS001G

40V max



Wheel diameter	185 mm (7-1/4")
Hole diameter	15.88 / 19 / 20 / 30 mm (5/8 / 3/4 / 13/16 / 1-3/16")
No load speed	6,400 min ⁻¹
Max cutting capacity	0°: 65 mm (2-9/16") 45°: 45 mm (1-3/4") 53°: 38 mm (1-1/2")
Dimensions (L x W x H)	446 x 196 x 270 mm (17-1/2 x 7-3/4 x 10-5/8")
Net weight	5.0 - 5.6 kg (11.0 - 12.3 lbs.)

XGT BL MOTOR ADT XPT

Circular Saw
5005BA

Continuous rating Input	860W
Wheel diameter	140 mm (5-1/2")
Hole diameter	15.88 mm (5/8")
No load speed	8,000 min ⁻¹
Max cutting capacity	0°: 45 mm (1-3/4") 45°: 31 mm (1-1/8")
Overall length	249 mm (9-13/16")
Net weight	3 kg (6.5 lbs.)

Circular Saw
HS6100

Continuous rating Input	1,100W
Wheel diameter	165 mm (6-1/2")
Hole diameter	20 / 30 mm (13/16 / 1-3/16")
No load speed	5,500 min ⁻¹
Max cutting capacity	0°: 54.5 mm (2-1/8") 45°: 39.5 mm (1-9/16") 50°: 35.5 mm (1-3/8")
Dimensions (L x W x H)	297 x 246 x 246 mm (11-3/4 x 9-11/16 x 9-11/16")
Net weight	3.5 kg (7.7 lbs.)

Cordless Circular Saw
HS301D

12V max



Wheel diameter	85 mm (3-3/8")
Hole diameter	15 / 20 mm (9/16 / 13/16")
No load speed	1,500 min ⁻¹
Max cutting capacity	0°: 25.5 mm (1") 45°: 16.5 mm (5/8")
Dimensions (L x W x H)	313 x 170 x 155 mm (12-3/8 x 6-11/16 x 6-1/8")
Net weight	1.6 - 1.7 kg (3.5 - 3.8 lbs.)

CXI

Cordless Rear Handle Saw
RS002G

40V max



Wheel diameter	260 mm (10-1/4")
Hole diameter	15.88 / 25 / 25.4 / 30 mm (5/8 / 1 / 1 / 1-3/16")
No load speed	4,000 min ⁻¹
Max cutting capacity	0°: 95 mm (3-3/4") 45°: 70 mm (2-3/4") 56°: 54.5 mm (2-1/8")
Dimensions (L x W x H)	489 x 193 x 309 mm (19-1/4 x 7-5/8 x 12-1/8")
Net weight	5.7 - 6.3 kg (12.6 - 13.9 lbs.)

XGT BL MOTOR AWS XPT

Cordless Rear Handle Saw
DRS780

18V x2



Wheel diameter	185 mm (7-1/4")
Hole diameter	15.88 / 19 / 20 / 20.6 / 30 mm (5/8 / 3/4 / 13/16 / 1-13/16")
No load speed	5,100 min ⁻¹
Max cutting capacity	0°: 65 mm (2-9/16") 45°: 45 mm (1-3/4") 53°: 38 mm (1-1/2")
Dimensions (L x W x H)	446 x 196 x 270 mm (17-1/2 x 7-3/4 x 10-5/8")
Net weight	5 - 5.6 kg (11.1 - 12.4 lbs.)

LXT BL MOTOR ADT XPT

Circular Saw
HS6101

Continuous rating Input	1,100W
Wheel diameter	165 mm (6-1/2")
Hole diameter	20 / 30 mm (13/16 / 1-3/16")
No load speed	5,500 min ⁻¹
Max cutting capacity	0°: 54.5 mm (2-1/8") 45°: 39.5 mm (1-9/16") 50°: 35.5 mm (1-3/8")
Dimensions (L x W x H)	297 x 246 x 246 mm (11-3/4 x 9-11/16 x 9-11/16")
Net weight	3.5 kg (7.7 lbs.)

Circular Saw
HS6601

Continuous rating Input	1,050W
Wheel diameter	165 mm (6-1/2")
Hole diameter	20 / 30 mm (13/16 / 1-3/16")
No load speed	5,200 min ⁻¹
Max cutting capacity	0°: 54.5 mm (2-1/8") 45°: 37.5 mm (1-1/2")
Dimensions (L x W x H)	296 x 232 x 243 mm (11-5/8 x 9-1/8 x 9-9/16")
Net weight	3.4 kg (7.6 lbs.)



Circular Saw HS6600



Continuous rating Input	1,050W
Wheel diameter	165 mm (6-1/2")
Hole diameter	15.88/ 20/ 25.4/ 30 mm (5/8/ 13/16/ 1/ 1-3/16")
No load speed	5,200 min ⁻¹
Max cutting capacity	0°: 54.5 mm (2-1/8") 45°: 37.5 mm (1-1/2")
Dimensions (L x W x H)	296 x 230 x 243 mm (11-5/8 x 9 x 9-9/16")
Net weight	3.5 kg (7.6 lbs.)



Circular Saw 5800NB



Continuous rating Input	900W
Wheel diameter	180 mm (7-1/8")
Hole diameter	19.05/ 20 mm (3/4/ 13/16")
No load speed	4,500 min ⁻¹
Max cutting capacity	0°: 64 mm (2-1/2") 45°: 43 mm (1-11/16")
Overall length	272 mm (10-3/4")
Net weight	3.5 kg (7.7 lbs.)



Circular Saw 5007MGA



Continuous rating Input	1,800W
Wheel diameter	185 mm (7-1/4")
Hole diameter	15.88/ 20/ 30 mm (5/8/ 13/16/ 1-3/16")
No load speed	5,800 min ⁻¹
Max cutting capacity	0°: 63.5 mm (2-1/2") 45°: 45 mm (1-3/4") 56°: 35 mm (1-3/8")
Dimensions (L x W x H)	317 x 240 x 265 mm (12-1/2 x 9-1/2 x 10-3/8")
Net weight	4.6 kg (10.1 lbs.)



Circular Saw 5007MG



Continuous rating Input	1,800W
Wheel diameter	185 mm (7-1/4")
Hole diameter	15.88/ 20/ 30 mm (5/8/ 13/16/ 1-3/16")
No load speed	5,800 min ⁻¹
Max cutting capacity	0°: 63.5 mm (2-1/2") 45°: 45 mm (1-3/4") 56°: 35 mm (1-3/8")
Dimensions (L x W x H)	317 x 240 x 265 mm (12-1/2 x 9-1/2 x 10-3/8")
Net weight	4.6 kg (10.1 lbs.)



Circular Saw 5007NF



Continuous rating Input	1,800W
Wheel diameter	185 mm (7-1/4")
Hole diameter	15.88/ 20/ 30 mm (5/8/ 13/16/ 1-3/16")
No load speed	5,800 min ⁻¹
Max cutting capacity	0°: 63.5 mm (2-1/2") 45°: 45 mm (1-3/4") 50°: 35 mm (1-3/8")
Dimensions (L x W x H)	317 x 240 x 265 mm (12-1/2 x 9-1/2 x 10-3/8")
Net weight	5 kg (11 lbs.)



Circular Saw 5007N



Continuous rating Input	1,800W
Wheel diameter	185 mm (7-1/4")
Hole diameter	15.88/ 20/ 30 mm (5/8/ 13/16/ 1-3/16")
No load speed	5,800 min ⁻¹
Max cutting capacity	0°: 63.5 mm (2-1/2") 45°: 45 mm (1-3/4") 50°: 35 mm (1-3/8")
Dimensions (L x W x H)	317 x 240 x 265 mm (12-1/2 x 9-1/2 x 10-3/8")
Net weight	5 kg (11 lbs.)



Circular Saw HS7611



Continuous rating Input	1,600W
Wheel diameter	185/ 190 mm (7-1/4/ 7-1/2")
Hole diameter	15.88/ 20/ 30 mm (5/8/ 13/16/ 1-3/16")
No load speed	5,500 min ⁻¹
Max cutting capacity	0°: 63/ 65 mm (2-1/2/ 2-9/16") 45°: 44/ 45 mm (1-3/4/ 1-3/4")
Dimensions (L x W x H)	311 x 240 x 261 mm (12-1/4 x 9-1/2 x 10-1/4")
Net weight	3.9 kg (8.7 lbs.)



Circular Saw HS7610



Continuous rating Input	1,600W
Wheel diameter	185/ 190 mm (7-1/4/ 7-1/2")
Hole diameter	15.88/ 19/ 20/ 25.4/ 30 mm (5/8/ 3/4/ 13/16/ 1/ 1-3/16")
No load speed	5,500 min ⁻¹
Max cutting capacity	0°: 63/ 65 mm (2-1/2/ 2-9/16") 45°: 44/ 45 mm (1-3/4/ 1-3/4")
Dimensions (L x W x H)	311 x 242 x 261 mm (12-1/4 x 9-1/2 x 10-1/4")
Net weight	3.9 kg (8.7 lbs.)



Circular Saw HS7010



Continuous rating Input	1,600W
Wheel diameter	185 - 190 mm (7-1/4 - 7-1/2")
Hole diameter	15.88/ 20/ 30 mm (5/8/ 13/16/ 1-3/16")
No load speed	5,500 min ⁻¹
Max cutting capacity	0°: 65/ 67 mm (2-9/16/ 2-5/8") 45°: 44/ 45 mm (1-3/4/ 1-3/4")
Dimensions (L x W x H)	300 x 240 x 261 mm (11-3/4 x 9-1/2 x 10-1/4")
Net weight	4 kg (8.9 lbs.)



Circular Saw 5007NB



Continuous rating Input	1,400W
Wheel diameter	185 mm (7-1/4")
Hole diameter	15.88/ 20 mm (5/8/ 13/16")
No load speed	5,800 min ⁻¹
Max cutting capacity	0°: 60 mm (2-3/8") 45°: 46 mm (1-3/4")
Overall length	295 mm (11-5/8")
Net weight	4.8 kg (10.5 lbs.)



Sawing

**Hypoid Saw
5377MG**

Wheel diameter	185 mm (7-1/4")
Hole diameter	15.88/ 19/ 20.6 mm (5/8/ 3/4/ 13/16")
No load speed	4,500 min ⁻¹
Max cutting capacity	0°: 60 mm (2-3/8") 45°: 44 mm (1-3/4") 50°: 40 mm (1-9/16")
Dimensions (L x W x H)	450 x 183 x 254 mm (17-3/4 x 7-1/4 x 10")
Net weight	6 kg (13.1 lbs.)

**Hypoid Saw
5477NB**

Wheel diameter	185 mm (7-1/4")
Hole diameter	15.88/ 20.6 mm (5/8/ 13/16")
No load speed	4,500 min ⁻¹
Max cutting capacity	0°: 60 mm (2-3/8") 45°: 44 mm (1-3/4") 50°: 40 mm (1-9/16")
Dimensions (L x W x H)	442 x 183 x 254 mm (17-3/8 x 7-1/4 x 10")
Net weight	6.3 kg (13.9 lbs.)

**Circular Saw
HS7000**

Continuous rating Input	1,200W
Wheel diameter	185 mm (7-1/4")
Hole diameter	20/ 30 mm (13/16/ 1-3/16")
No load speed	5,200 min ⁻¹
Max cutting capacity	0°: 65 mm (2-9/16") 45°: 43 mm (1-11/16")
Dimensions (L x W x H)	298 x 230 x 255 mm (11-11/16 x 9-1/16 x 10")
Net weight	3.8 kg (8.4 lbs.)

**Circular Saw
HS7600**

Continuous rating Input	1,200W
Wheel diameter	185 mm (7-1/4")
Hole diameter	15.88/ 19/ 20/ 25.4/ 30 mm (5/8/ 3/4/ 13/16/ 1/ 1-3/16")
No load speed	5,200 min ⁻¹
Max cutting capacity	0°: 64 mm (2-1/2") 45°: 42 mm (1-5/8")
Dimensions (L x W x H)	309 x 234 x 255 mm (12-1/8 x 9-1/4 x 10")
Net weight	3.8 kg (8.3 lbs.)

**Circular Saw
5806B**

Continuous rating Input	1,050W
Wheel diameter	185 mm (7-1/4")
Hole diameter	15.88/ 19.05/ 20/ 25.4 mm (5/8/ 3/4/ 13/16/ 1")
No load speed	5,200 min ⁻¹
Max cutting capacity	0°: 66 mm (2-5/8") 45°: 44 mm (1-11/16")
Overall length	282 mm (11-1/8")
Net weight	3.5 kg (7.6 lbs.)

**Circular Saw
HS7101**

Continuous rating Input	1,400W
Wheel diameter	190 mm (7-1/2")
Hole diameter	20/ 30 mm (13/16/ 1-3/16")
No load speed	5,500 min ⁻¹
Max cutting capacity	0°: 67 mm (2-5/8") 45°: 48.5 mm (1-15/16") 50°: 43.5 mm (1-11/16")
Dimensions (L x W x H)	310 x 246 x 258 mm (12-1/4 x 9-11/16 x 10-1/8")
Net weight	3.8 kg (8.4 lbs.)

**Circular Saw
HS7100**

Continuous rating Input	1,400W
Wheel diameter	190 mm (7-1/2")
Hole diameter	20/ 30 mm (13/16/ 1-3/16")
No load speed	5,500 min ⁻¹
Max cutting capacity	0°: 67 mm (2-5/8") 45°: 48.5 mm (1-15/16") 50°: 43.5 mm (1-11/16")
Dimensions (L x W x H)	310 x 246 x 258 mm (12-1/4 x 9-11/16 x 10-1/8")
Net weight	3.7 kg (8.2 lbs.)

**Circular Saw
HS7601**

Continuous rating Input	1,200W
Wheel diameter	190 mm (7-1/2")
Hole diameter	15.88/ 20/ 30 mm (5/8/ 13/16/ 1/ 1-3/16")
No load speed	5,200 min ⁻¹
Max cutting capacity	0°: 66 mm (2-5/8") 45°: 46 mm (1-13/16")
Dimensions (L x W x H)	309 x 232 x 255 mm (12-1/8 x 9-1/8 x 10")
Net weight	3.8 kg (8.4 lbs.)

**Circular Saw
5008MGA**

Continuous rating Input	1,800W
Wheel diameter	210 mm (8-1/4")
No load speed	5,200 min ⁻¹
Max cutting capacity	0°: 75.5 mm (3") 45°: 57 mm (2-1/4") 50°: 51.5 mm (2")
Dimensions (L x W x H)	332 x 243 x 277 mm (13-1/8 x 9-9/16 x 10-7/8")
Net weight	4.8 kg (10.6 lbs.)

**Circular Saw
5008MG**

Continuous rating Input	1,800W
Wheel diameter	210 mm (8-1/4")
Hole diameter	15.88/ 20/ 25/ 25.4/ 30 mm (5/8/ 13/16/ 1/ 1-3/16")
No load speed	5,200 min ⁻¹
Max cutting capacity	0°: 75.5 mm (3") 45°: 57 mm (2-1/4") 50°: 51.5 mm (2")
Dimensions (L x W x H)	332 x 243 x 277 mm (13-1/8 x 9-9/16 x 10-7/8")
Net weight	4.8 kg (10.6 lbs.)



Circular Saw 5903R



Continuous rating Input	2,000W
Wheel diameter	210 - 235 mm (9-1/4")
Hole diameter	25/ 25.4/ 30 mm (1/ 1-3/16")
No load speed	4,500 min ⁻¹
Max cutting capacity	0°: 85 mm (3-11/32") 45°: 64 mm (2-1/2")
Overall length	400 mm (15-3/4")
Net weight	7.2 kg (15.9 lbs.)



Circular Saw 5902B



Continuous rating Input	2,000W
Wheel diameter	235 mm (9-1/4")
Hole diameter	25/ 25.4/ 30 mm (1/ 1-3/16")
No load speed	4,100 min ⁻¹
Max cutting capacity	0°: 85 mm (3-3/8") 45°: 60 mm (2-3/8") 50°: 53 mm (2-1/16")
Overall length	380 mm (15")
Net weight	6.9 kg (15.1 lbs.)



Circular Saw N5900B



Continuous rating Input	2,000W
Wheel diameter	235 mm (9-1/4")
Hole diameter	25 mm (1")
No load speed	4,100 min ⁻¹
Max cutting capacity	0°: 85 mm (3-3/8") 45°: 60 mm (2-3/8") 50°: 53 mm (2-1/16")
Overall length	380 mm (15")
Net weight	6.8 kg (14.8 lbs.)



Circular Saw 5104S



Continuous rating Input	2,100W
Wheel diameter	270 mm (10-5/8")
Hole diameter	30 mm (1-3/16")
No load speed	3,800 min ⁻¹
Max cutting capacity	0°: 95/ 100 mm (3-3/4/ 3-15/16") 45°: 69/ 73 mm (2-3/4/ 2-7/8")
Dimensions (L x W x H)	405 x 315 x 323 mm (16 x 12-3/8 x 12-3/4")
Net weight	8.2 kg (18.2 lbs.)



Circular Saw 5104



Continuous rating Input	1,700W
Wheel diameter	260 - 270 mm (10-1/4 - 10-5/8")
Hole diameter	15.88/ 25.4 mm (5/8/ 1")
No load speed	3,800 min ⁻¹
Max cutting capacity	0°: 95/ 100 mm (3-3/4/ 3-15/16") 45°: 69/ 73 mm (2-3/4/ 2-7/8")
Dimensions (L x W x H)	405 x 315 x 323 mm (16 x 12-3/8 x 12-3/4")
Net weight	8.2 kg (18.2 lbs.)



Circular Saw 5103R



Continuous rating Input	2,100W
Wheel diameter	270 mm (10-5/8")
Hole diameter	25.4/ 30 mm (1/ 1-3/16")
No load speed	3,800 min ⁻¹
Max cutting capacity	0°: 100 mm (3-15/16") 45°: 73 mm (2-7/8")
Overall length	442 mm (17-3/8")
Net weight	9.3 kg (20.6 lbs.)



Circular Saw HS0600



Continuous rating Input	2,000W
Wheel diameter	255 - 270 mm (10 - 10-5/8")
Hole diameter	15.88/ 25/ 25.4/ 30 mm (5/8/ 1/ 1-3/16")
No load speed	4,300 min ⁻¹
Max cutting capacity	0°: 97/ 101 mm (3-13/16/ 4") 45°: 68/ 71 mm (2-11/16/ 2-13/16") 50°: 61/ 63 mm (2-3/8/ 2-1/2")
Dimensions (L x W x H)	418 x 273 x 324 mm (16-1/2 x 10-3/4 x 12-3/4")
Net weight	6.9 kg (15.2 lbs.)



Circular Saw 5103N



Continuous rating Input	1,750W
Wheel diameter	335 mm (13-1/8")
Hole diameter	25/ 25.4 mm (1")
No load speed	2,900 min ⁻¹
Max cutting capacity	0°: 128 mm (5") 45°: 91 mm (3-5/8")
Overall length	505 mm (19-7/8")
Net weight	8.9 kg (19.6 lbs.)

Circular Saw 5143R



Continuous rating Input	2,200W
Wheel diameter	355 mm (14")
Hole diameter	25.4/ 30 mm (1/ 1-3/16")
No load speed	2,700 min ⁻¹
Max cutting capacity	0°: 130 mm (5-1/8") 45°: 90 mm (3-1/2")
Overall length	607 mm (23-7/8")
Net weight	12.5 kg (27.6 lbs.)



Circular Saw 5402



Continuous rating Input	1,450W
Wheel diameter	415 mm (16-5/16")
Hole diameter	25/ 25.4 mm (1")
No load speed	2,200 min ⁻¹
Max cutting capacity	0°: 157 mm (6-3/16") 45°: 106 mm (4-3/16")
Overall length	615 mm (24-1/4")
Net weight	12.9 kg (28.4 lbs.)

Sawing

Circular Saw
5402NA

Continuous rating Input	1,650W
Wheel diameter	415 mm (16-5/16")
Hole diameter	25/25.4 mm (1")
No load speed	2,200 min ⁻¹
Max cutting capacity	0°: 158 mm (6-1/4") 45°: 106 mm (4-3/16")
Overall length	616 mm (24-1/4")
Net weight	12.5 kg (27.6 lbs.)

Cordless Plunge Cut Saw
SP001G

40V max



Wheel diameter	165 mm (6-1/2")
Hole diameter	20 mm (13/16")
No load speed	2,500 - 4,900 min ⁻¹
Bevel capacity	-1 - 48°
Max cutting capacity	0°: 56 mm (2-3/16") 45°: 40 mm (1-9/16") 48°: 38 mm (1-1/2")
Dimensions (L x W x H)	w/ BL4050F: 394 x 221 x 271 mm (15-1/2 x 8-3/4 x 10-5/8")
Net weight	4.4 - 5.0 kg (9.7 - 11.0 lbs.)

XGT BL MOTOR AWS XPT

Cordless Plunge Cut Saw
DSP600

18V x2



Wheel diameter	165 mm (6-1/2")
Hole diameter	20 mm (13/16")
No load speed	2,500 - 6,300 min ⁻¹
Bevel capacity	-1 - 48°
Max cutting capacity	0°: 56 mm (2-3/16") 45°: 40 mm (1-9/16") 48°: 38 mm (1-1/2")
Dimensions (L x W x H)	346 x 241 x 272 mm (13-5/8 x 9-1/2 x 10-3/4")
Net weight	4.4 - 5.1 kg (9.8 - 11.2 lbs.)

LXI BL MOTOR ADT

Band Saw
LB1200F

Continuous rating Input	900W
Blade length	2,240 mm (88")
Blade speed	High: (50Hz) 800 (60Hz) 1,000 m/min (50Hz) 2,624 (60Hz) 3,280 ft/min Low: (50Hz) 400 (60Hz) 500 m/min (50Hz) 1,312 (60Hz) 1,640 ft/min
Capacity	Thickness of cut: 165 mm (6-1/2") Throat: 305 mm (12")
Dimensions (L x W x H)	615 x 775 x 1,600 mm (24-1/4 x 30-1/2 x 63")
Net weight	82 kg (181.2 lbs.)

Circular Saw with Dust Collection
5057KB

Continuous rating Input	1,400W
Wheel diameter	185 mm (7-1/4")
Hole diameter	15.88/ 20/ 30 mm (5/8/ 13/16/ 1-3/16")
No load speed	5,800 min ⁻¹
Max cutting capacity	0°: 60 mm (2-3/8") 45°: 30 mm (1-1/8")
Overall length	354 mm (14")
Net weight	5.1 kg (11.2 lbs.)

Cordless Plunge Cut Saw
DSP601

18V x2



Wheel diameter	165 mm (6-1/2")
Hole diameter	20 mm (13/16")
No load speed	2,500 - 6,300 min ⁻¹
Bevel capacity	-1 - 48°
Max cutting capacity	0°: 56 mm (2-3/16") 45°: 40 mm (1-9/16") 48°: 38 mm (1-1/2")
Dimensions (L x W x H)	346 x 241 x 272 mm (13-5/8 x 9-1/2 x 10-3/4")
Net weight	4.4 - 5.1 kg (9.8 - 11.2 lbs.)

LXI BL MOTOR ADT AWS

Plunge Cut Circular Saw
SP6000

Continuous rating Input	1,300W
Wheel diameter	165 mm (6-1/2")
Hole diameter	20 mm (13/16")
Max cutting capacity	0°: 56 mm (2-3/16") 45°: 40 mm (1-9/16") 48°: 38 mm (1-1/2")
No load speed	2,200 - 6,400 min ⁻¹
Dimensions (L x W x H)	341 x 225 x 250 mm (13-3/8 x 8-7/8 x 9-7/8")
Net weight	4.1 kg (9 lbs.)



Sawing

Cordless Jig Saw JV002G

40V max



Stroke length	26 mm (1")
Strokes per minute	0 - 3,500 min ⁻¹
Capacity	Wood: 135 mm (5-5/16") Mild steel: 10 mm (3/8") Aluminum: 20 mm (13/16")
Bevel range	0 - 45°
Dimensions (L x W x H)	w/ BL4025: 272 x 84 x 208 mm (10-3/4 x 3-5/16 x 8-3/16")
Net weight	2.7 - 3.0 kg (6.0 - 6.6 lbs.)



Cordless Jig Saw JV001G

40V max



Stroke length	26 mm (1")
Strokes per minute	800 - 3,500 min ⁻¹
Capacity	Wood: 135 mm (5-5/16") Mild steel: 10 mm (3/8") Aluminum: 20 mm (13/16")
Bevel range	0 - 45°
Dimensions (L x W x H)	w/ BL4040: 298 x 84 x 189 mm (11-3/4 x 3-5/16 x 7-7/16")
Net weight	2.6 - 2.9 kg (5.7 - 6.4 lbs.)



Cordless Jig Saw DJV182

18V



Stroke length	26 mm (1")
Strokes per minute	800 - 3,500 min ⁻¹
Capacity	Wood: 135 mm (5-5/16") Steel: 10 mm (3/8")
Bevel range	0 - 45°
Dimensions (L x W x H)	266 x 77 x 208 mm (10-1/2 x 3 x 8-3/16")
Net weight	2.4 - 2.7 kg (5.2 - 5.9 lbs.)



Cordless Jig Saw DJV181

18V



Stroke length	26 mm (1")
Strokes per minute	800 - 3,500 min ⁻¹
Capacity	Wood: 135 mm (5-5/16") Steel: 10 mm (3/8")
Bevel range	0 - 45°
Dimensions (L x W x H)	298 x 77 x 189 mm (11-3/4 x 3 x 7-7/16")
Net weight	2.3 - 2.6 kg (5 - 5.7 lbs.)



Cordless Jig Saw DJV180

18V



Stroke length	26 mm (1")
Strokes per minute	0 - 2,600 min ⁻¹
Capacity	Wood: 135 mm (5-5/16") Steel: 10 mm (3/8")
Bevel range	0 - 45°
Dimensions (L x W x H)	257 x 73 x 208 mm (10-1/8 x 2-7/8 x 8-3/16")
Net weight	2.7 - 3 kg (6 - 6.7 lbs.)



Cordless Jig Saw DJV185

18V



Stroke length	23 mm (7/8")
Strokes per minute	800 - 3,000 min ⁻¹
Capacity	Wood: 135 mm (5-5/16") Mild steel: 10 mm (3/8") Aluminum: 20 mm (13/16")
Bevel range	0 - 45°
Dimensions (L x W x H)	w/ BL1860B: 259 x 77 x 183 mm (10-1/4 x 3 x 7-1/4")
Net weight	2.0 - 2.3 kg (4.4 - 5.1 lbs.)



Cordless Jig Saw DJV184

18V



Stroke length	23 mm (7/8")
Strokes per minute	0 - 3,000 min ⁻¹
Capacity	Wood: 135 mm (5-5/16") Mild steel: 10 mm (3/8") Aluminum: 20 mm (25/32")
Bevel range	0 - 45°
Dimensions (L x W x H)	259 x 77 x 205 mm (10-1/4 x 3 x 8-1/8")
Net weight	2.1 - 2.4 kg (4.6 - 5.3 lbs.)



Cordless Jig Saw JV103D

12V max



Stroke length	23 mm (7/8")
Strokes per minute	800 - 3,000 min ⁻¹
Max cutting capacity at 0°	Wood / Aluminum / Mild Steel: 90 / 20 / 10 mm (3-1/2 / 13/16 / 3/8")
Bevel range	0 - 45°
Dimensions (L x W x H)	237 x 76 x 206 mm (9-3/8 x 3 x 8-1/8")
Net weight	1.9 - 2 kg (4.1 - 4.4 lbs.)



Cordless Jig Saw JV102D

12V max



Stroke length	23 mm (7/8")
Strokes per minute	800 - 3,000 min ⁻¹
Max cutting capacity at 0°	Wood / Aluminum / Mild Steel: 90 / 20 / 10 mm (3-1/2 / 13/16 / 3/8")
Bevel range	0 - 45°
Dimensions (L x W x H)	237 x 76 x 186 mm (9-3/8 x 3 x 7-3/8")
Net weight	1.8 - 1.9 kg (3.9 - 4.2 lbs.)



Cordless Jig Saw JV101D

12V max



Stroke length	18 mm (11/16")
Strokes per minute	0 - 2,900 min ⁻¹
Max cutting capacity at 0°	Wood / Aluminum / Mild Steel: 65 / 4 / 2 mm (2-9/16 / 5/32 / 1/16")
Bevel range	0 - 45°
Dimensions (L x W x H)	232 x 76 x 196 mm (9-1/8 x 3 x 7-3/4")
Net weight	1.8 - 1.9 kg (3.9 - 4.3 lbs.)



Sawing

Cordless Jig Saw
JV183D

18V



Stroke length	18 mm (11/16")
Strokes per minute	0 - 2,900 min ⁻¹
Capacity	Wood: 65 mm (2-9/16") Steel: 6 mm (1/4")
Bevel range	0 - 45°
Dimensions (L x W x H)	248 x 76 x 196 mm (9-3/4 x 3 x 7-3/4")
Net weight	2 kg (4.4 lbs.)

Jig Saw
4350FCT

Continuous rating Input	720W
Stroke length	26 mm (1")
Strokes per minute	800 - 2,800 min ⁻¹
Capacity	Wood: 135 mm (5-5/16") Steel: 10 mm (3/8")
Bevel range	0 - 45°
Dimensions (L x W x H)	236 x 73 x 207 mm (9-1/4 x 2-7/8 x 8-1/8")
Net weight	2.7 kg (5.8 lbs.)

Jig Saw
4350CT

Continuous rating Input	720W
Stroke length	26 mm (1")
Strokes per minute	800 - 2,800 min ⁻¹
Capacity	Wood: 135 mm (5-5/16") Steel: 10 mm (3/8")
Bevel range	0 - 45°
Dimensions (L x W x H)	236 x 73 x 207 mm (9-1/4 x 2-7/8 x 8-1/8")
Net weight	2.7 kg (5.8 lbs.)

Jig Saw
4351FCT

Continuous rating Input	720W
Stroke length	26 mm (1")
Strokes per minute	800 - 2,800 min ⁻¹
Capacity	Wood: 135 mm (5-5/16") Steel: 10 mm (3/8")
Bevel range	0 - 45°
Dimensions (L x W x H)	271 x 73 x 187 mm (10-11/16 x 2-7/8 x 7-3/8")
Net weight	2.6 kg (5.7 lbs.)

Jig Saw
4351CT

Continuous rating Input	720W
Stroke length	26 mm (1")
Strokes per minute	800 - 2,800 min ⁻¹
Capacity	Wood: 135 mm (5-5/16") Steel: 10 mm (3/8")
Bevel range	0 - 45°
Dimensions (L x W x H)	271 x 73 x 187 mm (10-11/16 x 2-7/8 x 7-3/8")
Net weight	2.6 kg (5.7 lbs.)

Jig Saw
4350T

Continuous rating Input	580W
Stroke length	26 mm (1")
Strokes per minute	2,800 min ⁻¹
Capacity	Wood: 135 mm (5-5/16") Steel: 10 mm (3/8")
Bevel range	0 - 45°
Dimensions (L x W x H)	236 x 73 x 207 mm (9-1/4 x 2-7/8 x 8-1/8")
Net weight	2.7 kg (5.8 lbs.)

Jig Saw
4351T

Continuous rating Input	580W
Stroke length	26 mm (1")
Strokes per minute	2,800 min ⁻¹
Capacity	Wood: 135 mm (5-5/16") Steel: 10 mm (3/8")
Bevel range	0 - 45°
Dimensions (L x W x H)	271 x 73 x 187 mm (10-11/16 x 2-7/8 x 7-3/8")
Net weight	2.6 kg (5.7 lbs.)

Jig Saw
JV0600

Continuous rating Input	650W
Stroke length	23 mm (7/8")
Strokes per minute	500 - 3,100 min ⁻¹
Capacity	Wood: 90 mm (3-1/2") Steel: 10 mm (3/8")
Bevel range	0 - 45°
Dimensions (L x W x H)	236 x 77 x 199 mm (9-1/4 x 3 x 7-7/8")
Net weight	2.4 kg (5.3 lbs.)

Jig Saw
4329

Continuous rating Input	450W
Stroke length	18 mm (11/16")
Strokes per minute	500 - 3,100 min ⁻¹
Max cutting capacity at 0°	Wood: 65 mm (2-9/16") Steel: 6 mm (1/4")
Bevel range	0 - 45°
Dimensions (L x W x H)	223 x 77 x 197 mm (8-3/4 x 3 x 7-3/4")
Net weight	1.9 kg (4.2 lbs.)

Jig Saw
4328

Continuous rating Input	450W
Stroke length	18 mm (11/16")
Strokes per minute	500 - 3,100 min ⁻¹
Max cutting capacity at 0°	Wood: 65 mm (2-9/16") Steel: 6 mm (1/4")
Bevel range	0 - 45°
Dimensions (L x W x H)	217 x 77 x 197 mm (8-1/2 x 3 x 7-3/4")
Net weight	1.8 kg (4 lbs.)



Sawing

Jig Saw 4327



Continuous rating Input	450W
Stroke length	18 mm (11/16")
Strokes per minute	500 - 3,100 min ⁻¹
Capacity	Wood: 65 mm (2-9/16") Steel: 6 mm (1/4")
Bevel range	0 - 45°
Dimensions (L x W x H)	224 x 77 x 197 mm (8-7/8 x 3 x 7-3/4")
Net weight	1.9 kg (4.2 lbs.)



Jig Saw 4326



Continuous rating Input	450W
Stroke length	18 mm (11/16")
Strokes per minute	3,100 min ⁻¹
Capacity	Wood: 65 mm (2-9/16") Steel: 6 mm (1/4")
Bevel range	0 - 45°
Dimensions (L x W x H)	224 x 77 x 197 mm (8-7/8 x 3 x 7-3/4")
Net weight	1.9 kg (4.2 lbs.)



Cordless Recipro Saw JR002G

40V max



Stroke length	32 mm (1-1/4")
Strokes per minute	0 - 3,000 min ⁻¹
Capacity	Wood: 255 mm (10") Pipe: 130 mm (5-1/8")
Dimensions (L x W x H)	w/ BL4080F: 471 x 97 x 296 mm (18-1/2 x 3-13/16 x 11-5/8")
Net weight	4.6 - 5.8 kg (10.1 - 12.8 lbs.)



Cordless Recipro Saw JR001G

40V max



Stroke length	32 mm (1-1/4")
Strokes per minute	High / Low: 0 - 3,000 / 0 - 2,300 min ⁻¹
Capacity	Wood: 255 mm (10") Pipe: 130 mm (5-1/8")
Dimensions (L x W x H)	w/ BL4040: 472 x 88 x 239 mm (18-5/8 x 3-1/2 x 9-3/8")
Net weight	4.2 - 4.5 kg (9.3 - 9.9 lbs.)



Cordless Recipro Saw DJR360

18V x2



Stroke length	32 mm (1-1/4")
Strokes per minute	High / Low: 0 - 3,000 / 0 - 2,300 min ⁻¹
Capacity	Wood: 255 mm (10") Pipe: 130 mm (5-1/8")
Dimensions (L x W x H)	449 x 116 x 243 mm (17-3/4 x 4-9/16 x 9-9/16")
Net weight	4 - 4.7 kg (8.9 - 10.3 lbs.)



Cordless Recipro Saw DJR187

18V



Stroke length	32 mm (1-1/4")
Strokes per minute	High / Low: 0 - 3,000 / 0 - 2,300 min ⁻¹
Capacity	Wood: 255 mm (10") Pipe: 130 mm (5-1/8")
Dimensions (L x W x H)	439 x 83 x 231 mm (17-1/4 x 3-1/4 x 9-1/8")
Net weight	3.4 - 3.8 kg (7.6 - 8.3 lbs.)



Cordless Recipro Saw DJR189

18V



Stroke length	22 mm (7/8")
Strokes per minute	0 - 3,100 min ⁻¹
Capacity	Wood: 255 mm (10") Pipe: 130 mm (5-1/8")
Dimensions (L x W x H)	w/ BL1830B / BL1840B / BL1850B / BL1860B: 410 x 81 x 182 mm (16-1/8 x 3-3/16 x 7-1/8")
Net weight	2.2 - 2.5 kg (4.9 - 5.5 lbs.)



Cordless Recipro Saw DJR188

18V



Stroke length	20 mm (13/16")
Strokes per minute	0 - 3,000 min ⁻¹
Capacity	Wood: 255 mm (10") Pipe: 130 mm (5-1/8")
Dimensions (L x W x H)	w/ BL1830B / BL1840B / BL1850B / BL1860B: 316 x 81 x 220 mm (12-1/2 x 3-3/16 x 8-5/8")
Net weight	2.6 - 2.9 kg (5.7 - 6.4 lbs.)



Cordless Recipro Saw DJR186

18V



Stroke length	32 mm (1-1/4")
Strokes per minute	0 - 2,800 min ⁻¹
Capacity	Wood: 255 mm (10") Pipe: 130 mm (5-1/8")
Dimensions (L x W x H)	486 x 81 x 223 mm (19-1/8 x 3-3/16 x 8-3/4")
Net weight	3.5 - 3.8 kg (7.6 - 8.3 lbs.)



Cordless Recipro Saw DJR183

18V



Stroke length	13 mm (1/2")
Strokes per minute	0 - 3,000 min ⁻¹
Capacity	Wood: 50 mm (2") Pipe: 50 mm (2")
Dimensions (L x W x H)	w/ BL1830B / BL1840B / BL1850B / BL1860B: 398 x 81 x 220 mm (15-5/8 x 3-3/16 x 8-5/8")
Net weight	1.5 - 1.7 kg (3.3 - 3.8 lbs.)



Sawing

Cordless Recipro Saw
DJR185

18V



Stroke length	13 mm (1/2")
Strokes per minute	0 - 3,000 min ⁻¹
Capacity	Wood: 50 mm (2") Pipe: 50 mm (2")
Dimensions (L x W x H)	w/ BL1830B / BL1840B / BL1850B / BL1860B: 398 x 81 x 220 mm (15-5/8 x 3-3/16 x 8-5/8")
Net weight	1.5 - 1.8 kg (3.4 - 4.1 lbs.)

LXT**Cordless Recipro Saw**
JR105D

12V max



Stroke length	13 mm (1/2")
Strokes per minute	0 - 3,000 min ⁻¹
Capacity	Wood: 50 mm (2") Pipe: 50 mm (2")
Dimensions (L x W x H)	w/ BL1041B: 386 x 66 x 200 mm (15-1/4 x 2-5/8 x 7-7/8")
Net weight	1.3 - 1.5 kg (2.9 - 3.2 lbs.)

CXT**Recipro Saw**
JR3061T

Continuous rating Input	1,250W
Stroke length	32 mm (1-1/4")
Strokes per minute	0 - 3,000 min ⁻¹
Capacity	Pipe: 130 mm (5-1/8") Wood: 255 mm (10")
Dimensions (L x W x H)	487 x 95 x 177 mm (19-3/16 x 3-3/4 x 7")
Net weight	3.8 kg (8.4 lbs.)

**Recipro Saw**
JR1000FT

Continuous rating Input	340W
Stroke length	14 mm (9/16")
Strokes per minute	0 - 4,800 min ⁻¹
Capacity	Pipe: 25.4 mm (1") Wood: 55 mm (2-3/16")
Dimensions (L x W x H)	345 x 65 x 96 mm (13-5/8 x 2-9/16 x 3-3/4")
Net weight	1.6 kg (3.5 lbs.)

**Cordless Drywall Saw**
SD100D

12V max



Stroke length	6 mm (1/4")
Strokes per minute	0 - 6,000 min ⁻¹
Capacity	Drywall: 30 mm (1-3/16") Wood: 15 mm (9/16")
Dimensions (L x W x H)	239 x 79 x 266 mm (9-3/8 x 3-1/8 x 10-1/2")
Net weight	1.4 - 1.6 kg (3.2 - 3.5 lbs.)

CXT**Cordless Recipro Saw**
JR103D

12V max



Stroke length	13 mm (1/2")
Strokes per minute	0 - 3,300 min ⁻¹
Capacity	Wood: 50 mm (2") Pipe: 50 mm (2")
Dimensions (L x W x H)	w/ BL1041B: 386 x 66 x 200 mm (15-1/4 x 2-5/8 x 7-7/8")
Net weight	1.3 - 1.5 kg (2.9 - 3.3 lbs.)

CXT**Recipro Saw**
JR3070CT

Continuous rating Input	1,510W
Stroke length	32 mm (1-1/4")
Strokes per minute	0 - 2,800 min ⁻¹
Capacity	Pipe: 130 mm (5-1/8") Wood: 255 mm (10")
Overall length	485 mm (19-1/8")
Net weight	4.6 kg (10 lbs.)

AVT**Recipro Saw**
JR3051T

Continuous rating Input	1,200W
Stroke length	30 mm (1-3/16")
Strokes per minute	0 - 3,000 min ⁻¹
Capacity	Pipe: 130 mm (5-1/8") Wood: 255 mm (10")
Dimensions (L x W x H)	447 x 97 x 176 mm (17-5/8 x 3-13/16 x 6-15/16")
Net weight	3.2 - 3.3 kg (7.1 - 7.3 lbs.)

**Cordless Drywall Saw**
DSD180

18V



Stroke length	6 mm (1/4")
Strokes per minute	0 - 6,000 min ⁻¹
Capacity	Drywall: 30 mm (1-3/16") Wood: 15 mm (9/16")
Dimensions (L x W x H)	263 x 79 x 291 mm (10-3/8 x 3-1/8 x 11-3/8")
Net weight	1.7 - 2 kg (3.8 - 4.5 lbs.)

LXT**Scroll Saw**
SJ401

Continuous rating Input	50W
Stroke length	18 mm (11/16")
Strokes per minute	400 - 1,600 min ⁻¹
Capacity	Thickness of cut: 50 mm (2") Throat: 406 mm (16")
Overall length	600 mm (23-5/8")
Net weight	14 kg (30.87 lbs.)



PRODUCTS

Milling/Planing



-  Double Insulation
-  Variable Speed
-  Brake
-  Anti-restart function
-  Constant Speed
-  Soft Start
-  Dust Collection
-  Built-in Job Light
-  Carrying Case
-  Wooden Carrying Case

Milling/Planing

Cordless Trimmer
RT001G

40V max



Collet size	6/- 8/- mm (-/ 1/4/- / 3/8")
No load speed	10,000 - 31,000 min ⁻¹
Plunge capacity	w/ Trimmer base: 0 - 40 mm (0 - 1-9/16") w/ Plunge base: 0 - 35 mm (0 - 1-3/8")
Dimensions (L x W x H)	Plastic type, w/ BL4040: 141 x 90 x 251 mm (5-9/16 x 3-1/2 x 9-7/8") Aluminum type, w/ BL4040: 141 x 89 x 251 mm (4-7/8 x 3-1/2 x 9-7/8")
Net weight	2.2 - 2.5 kg (4.9 - 5.5 lbs.)

XGT MOTOR AWS XPT

Cordless Trimmer
DRT52

18V



Collet size	6/- mm (-/ 1/4")
No load speed	30,000 min ⁻¹
Dimensions (L x W x H)	134 x 90 x 220 mm (5-1/4 x 3-1/2 x 8-5/8")
Net weight	1.3 - 1.6 kg (2.9 - 3.5 lbs.)

LXI XPT

Cordless Trimmer
DRT50

18V



Collet size	6/- 8/- mm (-/ 1/4/- / 3/8")
Base inner	30 mm (1-3/16")
No load speed	10,000 - 30,000 min ⁻¹
Plunge capacity	w/ Trimmer base: 0 - 40 mm (0 - 1-9/16") w/ Plunge base: 0 - 35 mm (0 - 1-3/8")
Dimensions (L x W x H)	w/ BL1830B / BL1840B / BL1850B / BL1860B: 134 x 89 x 226 mm (5-1/4 x 3-1/2 x 8-7/8")
Net weight	1.8 - 2.1 kg (3.9 - 4.6 lbs.)

LXI BL MOTOR

Trimmer
RT0702C

Continuous rating Input	710W
Collet size	6/- 8/- mm (-/ 1/4/- / 3/8")
Base inner	30 mm (1-3/16")
No load speed	10,000 - 34,000 min ⁻¹
Plunge capacity	w/ Trimmer base: 0 - 40 mm (0 - 1-9/16") w/ Plunge base: 0 - 35 mm (0 - 1-3/8")
Dimensions (L x W x H)	89 x 89 x 210 mm (3-1/2 x 3-1/2 x 8-1/4")
Net weight	1.8 - 2.8 kg (4.0 - 6.2 lbs.)

Trimmer
RT0700C

Continuous rating Input	710W
Collet size	6/- 8/- mm (-/ 1/4/- / 3/8")
Base inner	30 mm (1-3/16")
No load speed	10,000 - 30,000 min ⁻¹
Dimensions (L x W x H)	89 x 89 x 200 mm (3-1/2 x 3-1/2 x 7-7/8")
Net weight	1.8 - 2.7 kg (3.9 - 6 lbs.)

Trimmer
3712

Continuous rating Input	530W
Collet size	6/- mm (-/ 1/4")
Base inner	28 mm (1-1/8")
No load speed	32,000 min ⁻¹
Plunge capacity	0 - 42 mm (0 - 1-5/8")
Dimensions (L x W x H)	102 x 122 x 314 mm (4 x 4-13/16 x 12-3/8")
Net weight	1.7 kg (3.7 lbs.)

Trimmer
3711

Continuous rating Input	530W
Collet size	6/- mm (-/ 1/4")
Base inner	35 mm (1-3/8")
No load speed	32,000 min ⁻¹
Plunge capacity	0 - 42 mm (0 - 1-5/8")
Dimensions (L x W x H)	82 x 90 x 211 mm (3-1/4 x 3-1/2 x 8-5/16")
Net weight	1.5 kg (3.3 lbs.)

Trimmer
3710

Continuous rating Input	530W
Collet size	6/- mm (-/ 1/4")
Base inner	28 mm (1-1/8")
No load speed	30,000 min ⁻¹
Dimensions (L x W x H)	102 x 122 x 302 mm (4 x 4-13/16 x 11-7/8")
Net weight	1.5 kg (3.3 lbs.)

Trimmer
3709

Continuous rating Input	530W
Collet size	6/ 6.35 mm (-/ 1/4")
Base inner	35 mm (1-3/8")
No load speed	30,000 min ⁻¹
Dimensions (L x W x H)	82 x 90 x 199 mm (3-1/4 x 3-1/2 x 7-7/8")
Net weight	1.5 kg (3.3 lbs.)

Trimmer
N3701

Continuous rating Input	440W
Collet size	6/- mm (-/ 1/4")
Base inner	35 mm (1-3/8")
No load speed	30,000 min ⁻¹
Overall height	181 mm (7-1/8")
Net weight	1.6 kg (3.4 lbs.)

Cordless Router RP001G

40V max

new



Collet size	12 / - mm (- / 1/2")
Base size	150 x 130 mm (5-7/8 x 5-1/8")
No load speed	8,000 - 25,000 min ⁻¹
Plunge capacity	60 mm (2-3/8")
Dimensions (L x W x H)	135 x 275 x 288 mm (5-5/16 x 10-7/8 x 11-3/8")
Net weight	4.0 - 5.2 kg (8.8 - 11.5 lbs.)

XGT BL MOTOR AWS XPT



Router RP2303FC



Continuous rating Input	2,100W
Collet size	12 / - mm (- / 1/2")
Base diameter	170 x 155 mm (6-11/16 x 6-1/8")
No load speed	9,000 - 23,000 min ⁻¹
Plunge capacity	0 - 70 mm (0 - 2-3/4")
Dimensions (L x W x H)	155 x 294 x 327 mm (6-1/8 x 11-5/8 x 12-7/8")
Net weight	6.2 kg (13.7 lbs.)



Router RP2302FC



Continuous rating Input	2,300W
Collet size	12 / - mm (- / 1/2")
Base diameter	170 x 155 mm (6-11/16 x 6-1/8")
No load speed	9,000 - 23,000 min ⁻¹
Plunge capacity	0 - 70 mm (0 - 2-3/4")
Dimensions (L x W x H)	155 x 294 x 327 mm (6-1/8 x 11-5/8 x 12-7/8")
Net weight	6.2 kg (13.7 lbs.)



Router RP2300FC



Continuous rating Input	2,300W
Collet size	6 / - 8 / 10 / 12 mm (- / 1/4 / 3/8 / - / 1/2")
Base diameter	170 x 155 mm (6-11/16 x 6-1/8")
No load speed	9,000 - 22,000 min ⁻¹
Plunge capacity	0 - 70 mm (0 - 2-3/4")
Dimensions (L x W x H)	155 x 294 x 312 mm (6-1/8 x 11-5/8 x 12-1/4")
Net weight	6.1 kg (13.5 lbs.)



Router RP2301FC



Continuous rating Input	2,100W
Collet size	6 / - 8 / 10 / 12 mm (- / 1/4 / 3/8 / - / 1/2")
Base diameter	170 x 155 mm (6-11/16 x 6-1/8")
No load speed	9,000 - 22,000 min ⁻¹
Plunge capacity	0 - 70 mm (0 - 2-3/4")
Dimensions (L x W x H)	155 x 294 x 312 mm (6-1/8 x 11-5/8 x 12-1/4")
Net weight	6.1 kg (13.5 lbs.)



Router RP1802F



Continuous rating Input	1,850W
Collet size	12 / - mm (- / 1/2")
Base diameter	170 x 155 mm (6-11/16 x 6-1/8")
No load speed	23,000 min ⁻¹
Plunge capacity	0 - 70 mm (0 - 2-3/4")
Dimensions (L x W x H)	155 x 294 x 312 mm (6-1/8 x 11-5/8 x 12-1/4")
Net weight	6.2 kg (13.7 lbs.)



Router RP1802



Continuous rating Input	1,850W
Collet size	12 / - mm (- / 1/2")
Base diameter	170 x 155 mm (6-11/16 x 6-1/8")
No load speed	23,000 min ⁻¹
Plunge capacity	0 - 70 mm (0 - 2-3/4")
Dimensions (L x W x H)	155 x 294 x 312 mm (6-1/8 x 11-5/8 x 12-1/4")
Net weight	6.2 kg (13.7 lbs.)



Router RP1803F



Continuous rating Input	1,650W
Collet size	12 / - mm (- / 1/2")
Base diameter	22,000 min ⁻¹
No load speed	170 x 155 mm (6-11/16 x 6-1/8")
Plunge capacity	0 - 70 mm (0 - 2-3/4")
Dimensions (L x W x H)	155 x 294 x 312 mm (6-1/8 x 11-5/8 x 12-1/4")
Net weight	6.2 kg (13.7 lbs.)



Router RP1803



Continuous rating Input	1,650W
Collet size	12 / - mm (- / 1/2")
Base diameter	170 x 155 mm (6-11/16 x 6-1/8")
No load speed	22,000 min ⁻¹
Plunge capacity	0 - 70 mm (0 - 2-3/4")
Dimensions (L x W x H)	155 x 294 x 312 mm (6-1/8 x 11-5/8 x 12-1/4")
Net weight	6.2 kg (13.7 lbs.)



Router RP1800F



Continuous rating Input	1,850W
Collet size	6 / - 8 / 10 / 12 mm (- / 1/4 / 3/8 / - / 1/2")
Base diameter	170 mm (6-11/16")
Base inner	62 mm (2-7/16")
No load speed	22,000 min ⁻¹
Plunge capacity	0 - 70 mm (0 - 2-3/4")
Dimensions (L x W x H)	155 x 294 x 312 mm (6-1/8 x 11-5/8 x 12-1/4")
Net weight	6 kg (13.2 lbs.)



Milling/Planing

Router
RP1800

Continuous rating Input	1,850W
Collet size	6/- 8/ 10/ 12 mm (- / 1/4/ 3/8/ - / 1/2")
Base diameter	170 mm (6-11/16")
Base inner	62 mm (2-7/16")
No load speed	22,000 min ⁻¹
Plunge capacity	0 - 70 mm (0 - 2-3/4")
Dimensions (L x W x H)	155 x 294 x 312 mm (6-1/8 x 11-5/8 x 12-1/4")
Net weight	6 kg (13.2 lbs.)

Router
3600H

Continuous rating Input	1,500W
Collet size	6/- 8/ 10/ 12 mm (- / 1/4/ 3/8/ - / 1/2")
Base diameter	160 mm (6-1/4")
Base inner	40 mm (1-9/16")
No load speed	24,000 min ⁻¹
Overall height	210 mm (8-1/4")
Net weight	4.4 kg (9.8 lbs.)

Router
RP1101

Continuous rating Input	1,250W
Collet size	- / - mm (1/2/ 1/4")
Base inner	30.5 mm (1-3/16")
No load speed	8,000 - 24,000 min ⁻¹
Plunge capacity	0 - 66 mm (2 - 19/32")
Overall height	291 mm (11-1/2")
Net weight	4.3 kg (9.4 lbs.)

Router
RD1101

Continuous rating Input	1,100W
Collet size	- / - mm (1/2/ 1/4")
Base inner	30.5 mm (1-3/16")
No load speed	8,000 - 24,000 min ⁻¹
Plunge capacity	0 - 55 mm (0 - 2-3/16")
Overall height	223 mm (8-3/4")
Net weight	3.4 kg (7.4 lbs.)

Router
RF1101

Continuous rating Input	1,100W
Collet size	- / - mm (1/2/ 1/4")
Base inner	30.5 mm (1-3/16")
No load speed	8,000 - 24,000 min ⁻¹
Plunge capacity	0 - 55 mm (0 - 2-3/16")
Overall height	223 mm (8-3/4")
Net weight	3.3 kg (7.3 lbs.)

Router
3601B

Continuous rating Input	930W
Collet size	6/- 8/ 10/ 12 mm (- / 1/4/ 3/8/ - / 1/2")
Base inner	40 mm (1-9/16")
No load speed	23,000 min ⁻¹
Overall height	190 mm (7-1/2")
Net weight	3.6 kg (7.9 lbs.)

Router
RP1111C

Continuous rating Input	1,100W
Collet size	6/- 8 mm (- / 1/4/ -")
Base inner	64 mm (2-1/2")
No load speed	8,000 - 27,500 min ⁻¹
Plunge capacity	0 - 57 mm (0 - 2-1/4")
Dimensions (L x W x H)	110 x 269 x 260 mm (4-5/16 x 10-5/8 x 10-1/4")
Net weight	3.3 kg (7.3 lbs.)

Router
RP0910

Continuous rating Input	900W
Collet size	6/- 8 mm (- / 1/4/ -")
Base inner	64 mm (2-1/2")
No load speed	27,000 min ⁻¹
Plunge capacity	0 - 57 mm (2 - 1/4")
Dimensions (L x W x H)	110 x 269 x 260 mm (4-5/16 x 10-5/8 x 10-1/4")
Net weight	3.3 kg (7.3 lbs.)

Router
RP0900

Continuous rating Input	900W
Collet size	6/- 8 mm (- / 1/4/ -")
Base inner	64 mm (2-1/2")
No load speed	27,000 min ⁻¹
Plunge capacity	0 - 35 mm (0 - 1-3/8")
Dimensions (L x W x H)	110 x 256 x 217 mm (4-5/16 x 10-3/32 x 8-17/32")
Net weight	2.7 kg (6 lbs.)

Chain Mortiser
7104L

Continuous rating Input	1,140W
No load speed	3,200 min ⁻¹
Capacity	Max hole width: 130 mm (5-1/8") Max hole depth: 155 mm (6-1/8")
Dimensions (L x W x H)	512 x 298 x 513 mm (20-3/16 x 11-3/4 x 20-1/4")
Net weight	17.8 - 18.2 kg (39.4 - 40.1 lbs.)

Milling/Planing

Cordless Plate Joiner DPJ180

18V

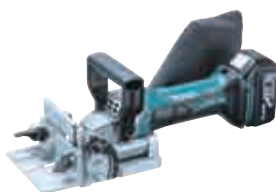

Wheel diameter	100 mm (4")
Hole diameter	22 mm (7/8")
No load speed	6,500 min ⁻¹
Dimensions (L x W x H)	351 x 139 x 149 mm (13-3/4 x 5-1/2 x 5-7/8")
Net weight	2.8 - 3.1 kg (6.2 - 6.8 lbs.)

LXT



Plate Joiner PJ7000

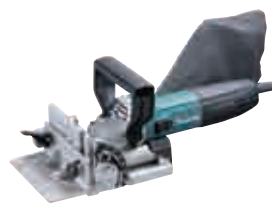

Continuous rating Input	701W
Wheel diameter	100 mm (4")
Hole diameter	22 mm (7/8")
No load speed	11,000 min ⁻¹
Dimensions (L x W x H)	302 x 139 x 145 mm (11-7/8 x 5-1/2 x 5-3/4")
Net weight	2.8 kg (6.2 lbs.)



Cordless Planer KP001G

40V max



Planing width	82 mm (3-1/4")
Planing depth	4 mm (5/32")
Shiplapping	25 mm (1")
No load speed	15,000 min ⁻¹
Dimensions (L x W x H)	w/ BL4080F: 424 x 156 x 175 mm (16-3/4 x 6-1/8 x 6-7/8")
Net weight	3.7 - 4.9 kg (8.2 - 10.8 lbs.)

XGT BL MOTOR AWS XPT



Cordless Planer DKP181

18V



Planing width	82 mm (3-1/4")
Planing depth	3 mm (1/8")
Shiplapping	25 mm (1")
No load speed	12,000 min ⁻¹
Dimensions (L x W x H)	w/ BL1830B / BL1840B / BL1850B / BL1860B: 366 x 156 x 166 mm (14-3/8 x 6-1/8 x 6-1/2")
Net weight	3.3 - 3.6 kg (7.3 - 7.9 lbs.)

LXT BL MOTOR ADT AWS



Cordless Planer DKP180

18V



Planing width	82 mm (3-1/4")
Planing depth	2.0 mm (5/64")
Shiplapping	9 mm (11/32")
No load speed	15,000 min ⁻¹
Dimensions (L x W x H)	w/ BL1830B / BL1840B / BL1850B / BL1860B: 333 x 157 x 160 mm (13-1/8 x 6-3/16 x 6-5/16")
Net weight	3.2 - 3.5 kg (7.1 - 7.9 lbs.)

LXT



Power Planer 1805N



Continuous rating Input	1,140W
Planing width	155 mm (1/8")
Planing depth	3 mm (1/16")
No load speed	15,000 min ⁻¹
Overall length	445 mm (17-1/2")
Net weight	7.9 kg (17.3 lbs.)



Power Planer 1804N



Continuous rating Input	960W
Planing width	136 mm (5-3/8")
Planing depth	3 mm (1/8")
No load speed	16,000 min ⁻¹
Overall length	445 mm (17-1/2")
Net weight	7.8 kg (17.2 lbs.)



Power Planer 1911B



Continuous rating Input	840W
Planing width	110 mm (4-5/16")
Planing depth	2 mm (1/16")
No load speed	16,000 min ⁻¹
Overall length	355 mm (14")
Net weight	4.1 kg (9.1 lbs.)



Power Planer KP0810C



Continuous rating Input	1,050W
Planing width	82 mm (3-1/4")
Planing depth	4 mm (5/32")
Shiplapping	25 mm (1")
No load speed	12,000 min ⁻¹
Dimensions (L x W x H)	290 x 168 x 176 mm (11-3/8 x 6-5/8 x 6-15/16")
Net weight	3.4 kg (7.5 lbs.)



Power Planer KP0810



Continuous rating Input	850W
Planing width	82 mm (3-1/4")
Planing depth	4 mm (5/32")
Shiplapping	25 mm (1")
No load speed	16,000 min ⁻¹
Dimensions (L x W x H)	290 x 168 x 176 mm (11-3/8 x 6-5/8 x 6-15/16")
Net weight	3.3 kg (7.3 lbs.)



Milling/Planing

Power Planer KP0800



Continuous rating Input	620W
Planing width	82 mm (3-1/4")
Planing depth	2.5 mm (3/32")
Shiplapping	9 mm (11/32")
No load speed	17,000 min ⁻¹
Dimensions (L x W x H)	285 x 158 x 158 mm (11-1/4 x 6-1/4 x 6-1/4")
Net weight	2.8 kg (6.2 lbs.)



Planer KP312S



Continuous rating Input	2,200W
Planing Width	312 mm (12-1/4")
Cutting depth	Cutting width 0 - 150 mm: 3.5 mm (1/8") Cutting width 150 - 240 mm: 2.0 mm (1/16") Cutting width 240 - 312 mm: 1.5 mm (1/16")
No load speed	12,000 min ⁻¹
Overall length	551 mm (21-3/4")
Net weight	18.4 kg (40.6 lbs.)



Planer KP312



Continuous rating Input	1,700W
Planing Width	312 mm (12-1/4")
Cutting depth	Cutting width 0 - 150 mm: 3.5 mm (1/8") Cutting width 150 - 240 mm: 2.0 mm (1/16") Cutting width 240 - 312 mm: 1.5 mm (1/16")
No load speed	12,000 min ⁻¹
Overall length	551 mm (21-3/4")
Net weight	18.4 kg (40.6 lbs.)



Planer 2012NB



Continuous rating Input	1,650W
Planing Width	304 mm (12")
Cutting depth	Cutting width 0 - 150 mm: 3 mm (1/8") Cutting width 150 - 240 mm: 1.5 mm (1/16")
Feed rate/min.	8.5 m (27.9 ft)
No load speed	8,500 min ⁻¹
Table size (L x W)	771 x 304 mm (30-3/8 x 12")
Dimensions (L x W x H)	483 x 771 x 401 mm (19 x 30-3/8 x 15-13/16")
Net weight	27.1 - 27.6 kg (59.7 - 60.9 lbs.)



Concrete Planer PC5000C



Continuous rating Input	1,400W
Wheel diameter	125 mm (5")
Hole diameter	22.23 mm (7/8")
No load speed	10,000 min ⁻¹
Dimensions (L x W x H)	437 x 235 x 195 mm (17-1/8 x 9-1/4 x 7-5/8")
Net weight	4 kg (8.9 lbs.)



Concrete Planer PC5001C



Continuous rating Input	1,400W
Wheel diameter	125 mm (5")
Hole diameter	22.23 mm (7/8")
No load speed	10,000 min ⁻¹
Dimensions (L x W x H)	479 x 182 x 195 mm (18-13/16 x 7-1/8 x 7-5/8")
Net weight	4 kg (8.9 lbs.)



Concrete Planer PC5010C



Continuous rating Input	1,400W
Wheel diameter	125 mm (5")
Hole diameter	22.23 mm (7/8")
No load speed	4,000 - 9,000 min ⁻¹
Dimensions (L x W x H)	350 x 231 x 179 mm (13-3/4 x 9-1/8 x 7")
Net weight	2.5 - 3.6 kg (5.5 - 7.9 lbs.)



Curved Planer 1002BA



Continuous rating Input	1,050W
Planing width	110 mm (4-3/8")
Planing depth	4 mm (5/32")
Max curved radial cuts	Concave: 300 mm (11-13/16")
No load speed	15,000 min ⁻¹
Overall length	339 mm (13-5/16")
Net weight	5.2 kg (11.4 lbs.)



Groove Cutter 3501N



Continuous rating Input	1,160W
Max cutter blade size	Diameter x Width: 120 x 36 mm (4-3/4 x 1-3/8")
Max cutting depth	Cutter / Cutter: 30 mm (1-1/8") / 65 mm (2-1/2")
No load speed	6,500 min ⁻¹
Overall length	365 mm (14-3/8")
Net weight	7.2 kg (15.8 lbs.)



Milling/Planing

Cordless Cut-Out Tool DCO181

18V

Collet capacity	3, 6 mm or 1/8, 1/4"
No load speed	32,000 min ⁻¹
Circumference of grip portion	210 mm (8-1/4")
Dimensions (L x W x H)	w/ BL1830B / BL1840B / BL1850B / BL1860B: 311 x 79 x 117 mm (12-1/4 x 3-1/8 x 4-5/8")
Net weight	1.4 - 1.7 kg (3.1 - 3.7 lbs.)



LXT **BL** **AWS** **XPT**



Cordless Cut-Out Tool DCO180

18V

Collet capacity	3.18, 6.35 mm or 1/8, 1/4"
No load speed	30,000 min ⁻¹
Dimensions (L x W x H)	296 x 77 x 118 mm (11-5/8 x 3 x 4-5/8")
Net weight	1.5 - 1.8 kg (3.3 - 4 lbs.)



LXT



Cut-out Tool 3706

Continuous rating Input	550W
Collet capacity	3.18, 6.35 mm or 1/8, 1/4"
No load speed	32,000 min ⁻¹
Overall height	250 mm (9-7/8")
Net weight	1.1 kg (2.4 lbs.)



PRODUCTS

Fastening/Fixing



Brake



Anti-restart function



Torque Setting 6



Depth Adjustment



Sequential and Bump-fire



Wire Collated Nail



Sheet Collated Nail



Inlet Filter



Auto Firing Stop



Built-in Job Light



Carrying Case

Fastening/Fixing

Cordless Rivet Gun DRV250

18V



Pulling force	20 kN (4,500 lbs.)
Stroke	30 mm (1-3/16")
Rivet diameter range	2.4 - 6.4 mm (3/32 - 1/4")
Center height	26 mm (1")
Work amount	w/ BL1860B: 1,900 pcs
Dimensions (L x W x H)	w/ BL1830B / BL1840B / BL1850B / BL1860B: 323 x 80 x 287 mm (12-3/4 x 3-1/8 x 11-1/4")
Net weight	2.1 - 2.4 kg (4.6 - 5.3 lbs.)

LXI BL MOTOR XPT



Cordless Rivet Gun DRV150

18V



Pulling force	10 kN (2,200 lbs.)
Stroke	25 mm (1")
Rivet diameter range	2.4 - 4.8 mm (3/32 - 3/16")
Center height	26 mm (1")
Work amount	w/ BL1860B: 2,800 pcs
Dimensions (L x W x H)	w/ BL1830B / BL1840B / BL1850B / BL1860B: 313 x 80 x 287 mm (12-3/8 x 3-1/8 x 11-1/4")
Net weight	1.9 - 2.2 kg (4.2 - 4.9 lbs.)

LXI BL MOTOR XPT



Cordless Rebar Tying Tool DTR181

18V



Applicable rebars	D16 x D16 - [D13 x 2] x [D16 x 2]
Applicable tie wire	Annealed wire: 21 Ga (0.8 mm) Galvanized wire: 21 Ga (0.8 mm) Poly coated wire: 20 Ga (0.9 mm)
Dimensions (L x W x H)	w/ BL1830B / BL1840B / BL1850B / BL1860B: 317 x 93 x 318 mm (12-1/2 x 3-5/8 x 12-1/2")
Net weight	2.4 - 2.7 kg (5.3 - 6.0 lbs.)

LXI BL MOTOR XPT



Cordless Rebar Tying Tool DTR180

18V



Tie wire	Dia. 0.8 mm
Applicable rebars	D10 x D10 - [D13 x 2] x [D13 x 2]
Dimensions (L x W x H)	w/ BL1830B / BL1840B / BL1850B / BL1860B: 304 x 93 x 318 mm (12 x 3-2/3 x 12-1/2")
Net weight	2.3 - 2.6 kg (5.1 - 5.7 lbs.)

LXI BL MOTOR XPT



Cordless Brad Nailer FN001G

40V max



Capacity	Length: 15, 20, 25, 30, 35, 40 mm (5/8, 3/4, 1, 1-3/16, 1-3/8, 1-5/8") Gauge: 18 Ga
Magazine capacity	100
Shot q'ty on a single full battery charge	w/ BL4025: 5,000
Dimensions (L x W x H)	w/ BL4050F: 291 x 86 x 263 mm (11-1/2 x 3-3/8 x 10-3/8")
Net weight	2.6 - 3.2 kg (5.7 - 7.1 lbs.)

XGT BL MOTOR XPT



Cordless Brad Nailer DBN500

18V



Capacity	Length: 15 - 50 mm (5/8 - 2") Gauge: 18 Ga
Magazine capacity	110
Shot q'ty on a single full battery charge	w/ BL1840B: 1,300
Quick response (pcs per second)	1.5 - 2
Center height	28 mm (1-1/8")
Dimensions (L x W x H)	294 x 97 x 318 mm (11-5/8 x 3-13/16 x 12-1/2")
Net weight	3.2 - 3.5 kg (7.05 - 7.72 lbs.)

LXI



Cordless Brad Nailer DFN350

18V



Capacity	Length: 15 - 35 mm (5/8 - 1-3/8") Gauge: 18 Ga
Magazine capacity	110
Shot q'ty on a single full battery charge	w/ BL1850B: 4,000
Dimensions (L x W x H)	w/ BL1830B / BL1840B / BL1850B / BL1860B: 257 x 79 x 228 mm (10-1/8 x 3-1/8 x 9")
Net weight	2.1 - 2.4 kg (4.6 - 5.3 lbs.)

LXI XPT



Cordless Brad Nailer GF600

7.2V



Capacity	Length: 15 - 64 mm (5/8 - 2-1/2") Gauge: 16 Ga
Magazine capacity	100
Dimensions (L x W x H)	266 x 90 x 305 mm (10-1/2 x 3-1/2 x 12")
Net weight	2.2 kg (4.8 lbs.)



Pneumatic Brad Nailer AF506



Capacity	Length: 15 - 50 mm (5/8 - 2") Gauge: 18 Ga
Operating pressure	0.49 - 0.83 MPa (70 - 120 PSI)
Magazine capacity	100
Dimensions (L x W x H)	250 x 70 x 256 mm (9-7/8 x 2-3/4 x 10-1/8")
Net weight	1.3 kg (2.9 lbs.)



Cordless Finish Nailer DBN600

18V



Capacity	Length: 25 - 64 mm (1 - 2-1/2") Gauge: 16 Ga
Magazine Capacity	110
Shot q'ty on a single full battery charge	w/ BL1840B: 800
Quick response (pcs per second)	1 - 1.5
Center height	35 mm (1-3/8")
Dimensions	w/ BL1830B / BL1840B / BL1850B / BL1860B: 296 x 108 x 318 mm (11-5/8 x 4-1/4 x 12-1/2")
Net weight	3.4 - 3.8 kg (7.5 - 8.4 lbs.)

LXI



Fastening/Fixing

Pneumatic Finish Nailer
AF635

Capacity	Length: 32 - 64 mm (1-1/4 - 2-1/2") Gauge: 15 Ga
Operating pressure	0.49 - 0.83 MPa (70 - 120 PSI)
Magazine capacity	100
Dimensions (L x W x H)	339 x 100 x 309 mm (13-3/8 x 3-15/16 x 12-1/8")
Net weight	1.8 kg (4 lbs.)

Pneumatic Finish Nailer
AF601

Capacity	Length: 25 - 64 mm (1 - 2-1/2") Gauge: 16 Ga
Operating pressure	0.49 - 0.83 MPa (70 - 120 PSI)
Magazine capacity	100
Dimensions (L x W x H)	304 x 95 x 297 mm (12 x 3-3/4 x 11-3/4")
Net weight	1.7 kg (3.8 lbs.)

Cordless Pin Nailer
PT001G

40V max



Capacity	Length: 15, 18, 25, 30, 35 mm (5/8, 11/16, 1, 1-3/16, 1-3/8") Dia.: 0.6 mm (1/32") Gauge: 23 Ga
Magazine capacity	120
Approx. work volume on a full battery charge	w/ BL4025: 6,000 shots
Dimensions (L x W x H)	w/ BL4050F: 291 x 86 x 253 mm (11-1/2 x 3-3/8 x 10")
Net weight	2.4 - 3.0 kg (5.3 - 6.6 lbs.)

Cordless Pin Nailer
DPT353

18V



Capacity	Length: 15, 18, 25, 30, 35 mm (5/8, 11/16, 1, 1-3/16, 1-3/8") Dia.: 0.6 mm (1/32") Gauge: 23 Ga
Magazine capacity	120
Dimensions (L x W x H)	257 x 79 x 226 mm (10-1/8 x 3-1/8 x 8-7/8")
Net weight	2 - 2.3 kg (4.4 - 5.1 lbs.)

Cordless Pin Nailer
PT354D

12V max



Capacity	Length: 15, 18, 25, 30, 35 mm (5/8, 11/16, 1, 1-3/16, 1-3/8") Dia.: 0.6 mm (1/32") Gauge: 23 Ga
Magazine capacity	120
Dimensions (L x W x H)	231 x 66 x 226 mm (9-1/8 x 2-5/8 x 8-7/8")
Net weight	1.8 - 2 kg (4 - 4.4 lbs.)

Pneumatic Pin Nailer
AF353

Capacity	Length: 15 - 35 mm (5/8 - 1-3/8") Gauge: 23 Ga
Magazine capacity	130
Operating pressure	0.45 - 0.69 MPa (65 - 100 PSI)
Dimensions (L x W x H)	208 x 66 x 191 mm (8-3/16 x 2-5/8 x 7-1/2")
Net weight	0.9 kg (2 lbs.)

Pin Nailer
AF201Z

Capacity	Length: 12 - 25 mm (1/2 - 1")
Magazine capacity	100
Operating pressure	0.44 - 0.86 MPa (65 - 125 PSI)
Dimensions (L x W x H)	240 x 45 x 170 mm (9-1/2 x 1-3/4 x 6-3/4")
Net weight	0.9 kg (2 lbs.)

Cordless Stapler
DST221

18V



Staple	Width: 10 mm (3/8") Length: 10, 13, 16, 19, 22 mm (3/8, 1/2, 5/8, 3/4, 7/8") Gauge: 0.6 x 1.2 mm (1/32 x 1/16")
Magazine capacity	98
Dimensions (L x W x H)	251 x 91 x 212 mm (9-7/8 x 3-5/8 x 8-3/8")
Net weight	2.1 - 2.4 kg (4.7 - 5.3 lbs.)

Cordless Stapler
DST112

18V



Staple	Width: 10 mm (3/8") Length: 7 - 10 mm (9/32 - 3/8")
Magazine capacity	150 (max 160)
Shot q'ty on a single full battery charge	w/ BL1830B: 6,000
Dimensions (L x W x H)	235 x 79 x 165 mm (9-1/4 x 3-1/8 x 6-1/2")
Net weight	1.5 - 1.8 kg (3.4 - 4 lbs.)

Cordless Stapler
ST113D

12V max



Staple	Width: 10 mm (3/8") Length: 7 - 10 mm (9/32 - 3/8")
Magazine capacity	150 (max 160)
Dimensions (L x W x H)	211 x 81 x 159 mm (8-5/16 x 3-3/16 x 6-1/4")
Net weight	1.3 kg (2.9 lbs.)



Pneumatic Pallet Coil Nailer AN960



Capacity	Length: 57 - 100 mm
Magazine capacity	225 - 300
Operating pressure	0.49 - 0.83 MPa (71 - 120 PSI)
Dimensions (L x W x H)	338 x 153 x 418 mm (7-1/2 x 6 x 16-1/2")
Net weight	5.1 kg (11.2 lbs.)



Pneumatic Pallet Coil Nailer AN961



Capacity	Length: 55 - 100 mm
Magazine capacity	225 - 300
Operating pressure	0.49 - 0.83 MPa (71 - 120 PSI)
Dimensions (L x W x H)	338 x 153 x 418 mm (7-1/2 x 6 x 16-1/2")
Net weight	5.3 kg (11.7 lbs.)



Pneumatic Pallet Coil Nailer AN760



Capacity	Length: 45 - 75 mm (1-3/4 - 2-15/16") Wire: 2.3 - 3.3 mm (0.0915 - 0.130")
Magazine capacity	200 - 300
Operating pressure	0.49 - 0.83 MPa (70 - 120 PSI)
Dimensions (L x W x H)	312 x 131 x 331 mm (12-1/4 x 5-1/8 x 13")
Net weight	3.2 kg (7.1 lbs.)



Pneumatic Pallet Coil Nailer AN560



Capacity	Length: 27 - 50 mm (1-1/16 - 2") Wire: 2.1 mm (3/32")
Magazine capacity	350 - 400
Operating pressure	0.49 - 0.78 MPa (70 - 115 PSI)
Dimensions (L x W x H)	300 x 127 x 280 mm (11-3/4 x 5 x 11")
Net weight	2.1 kg (4.6 lbs.)



Pneumatic Coil Nailer AN613



Capacity	Length: 38 - 65 mm (1-1/2 - 2-9/16") Gauge: 2.3 - 2.5 mm (3/32")
Operating pressure	0.49 - 0.83 MPa (70 - 120 PSI)
Magazine capacity	200 - 300
Dimensions (L x W x H)	275 x 127 x 319 mm (10-7/8 x 5 x 12-1/2")
Net weight	2.2 kg (4.9 lbs.)



Pneumatic Coil Nailer AN454



Capacity	Length: 19 - 45 mm (3/4 - 1-3/4") Nail gauge: 3.05 mm (0.120")
Driving stroke	82 mm
Cylinder bore diameter	41.6 mm (1-5/8")
Operating pressure	0.49 - 0.83 MPa (70 - 120 PSI)
Magazine capacity	120
Dimensions (L x W x H)	w/ Hook: 256 x 142 x 271 mm (10-1/8 x 5-5/8 x 10-5/8")
Net weight	2.4 kg (5.2 lbs.)



Wide Crown Stapler AT2550A



Capacity	Length: 25 - 50 mm (1 - 2") Width: 25 mm (1") Gauge: 16 Ga
Operating pressure	0.44 - 0.83 MPa (65 - 120 PSI)
Magazine capacity	140
Dimensions (L x W x H)	370 x 76 x 260 mm (14-1/2 x 3 x 10-1/4")
Net weight	2.3 kg (5.1 lbs.)



Medium Crown Stapler AT1150A



Capacity	Length: 25 - 50 mm (1 - 2") Width: 11 mm (7/16") Gauge: 16 Ga
Operating pressure	0.44 - 0.83 MPa (65 - 120 PSI)
Magazine capacity	140
Dimensions (L x W x H)	370 x 87 x 290 mm (14-1/2 x 3-7/16 x 11-3/8")
Net weight	2.3 kg (5.1 lbs.)



Narrow Crown Stapler AT638A



Capacity	Length: 13 - 38 mm (1/2 - 1-1/2") Gauge: 18 Ga Width: 5.7 mm
Operating pressure	0.49 - 0.83 MPa (70 - 120 PSI)
Magazine capacity	100
Dimensions (L x W x H)	230 x 75 x 251 mm (9 x 2-15/16 x 9-7/8")
Net weight	1.2 kg (2.7 lbs.)



Narrow Crown Stapler AT638



Capacity	Length: 15 - 38 mm (5/8 - 1-1/2") Gauge: 18 Ga Width: 5.7 mm
Operating pressure	0.39 - 0.78 MPa (60 - 115 PSI)
Magazine capacity	100
Dimensions (L x W x H)	247 x 62 x 246 mm (9-3/4 x 2-7/16 x 9-11/16")
Net weight	1.2 kg (2.7 lbs.)



Fastening/Fixing

Cordless Framing Nailer DBN900

18V

new



Capacity	Length: 50 - 90 mm (2 - 3-1/2") Gauge: 2.9 - 3.3 mm (0.113 - 0.131") Collation angle display: 30 - 34°
Magazine capacity	51 - 58 nails
Work volume on a full battery charge	1,000
(Battery)	BL1860B
Rapid firing capability per second	2
Dimensions (L x W x H)	326 x 186 x 358 mm (12-7/8 x 7-3/8 x 14-1/8")
Net weight	4.9 - 5.4 kg (10.8 - 11.9 lbs.)

LXI MOTOR XPT



Cordless Framing Nailer DBN901

18V

new



Capacity	Length: 50 - 90 mm (2 - 3-1/2") Gauge: 2.9 - 3.8 mm (0.113 - 0.148") Collation angle display: 21°
Magazine capacity	36 - 41 nails
Work volume on a full battery charge	1,000
(Battery)	BL1860B
Rapid firing capability per second	2
Dimensions (L x W x H)	389 x 189 x 358 mm (15-1/4 x 7-7/16 x 14-1/8")
Net weight	5.0 - 5.4 kg (11.0 - 11.9 lbs.)

LXI MOTOR XPT



Pneumatic Framing Nailer AN943



Capacity	Length: 50 - 90 mm (2 - 3-1/2")
Operating pressure	0.44 - 0.83 MPa (65 - 120 PSI)
Magazine capacity	60 - 84
Dimensions (L x W x H)	455 x 109 x 365 mm (17-7/8 x 4-1/4 x 14-3/8")
Net weight	4 kg (8.8 lbs.)



Pneumatic Framing Nailer AN924



Capacity	Length: 50 - 90 mm (2 - 3-1/2")
	Dia.: 2.9 - 3.76 mm (0.113 - 0.148")
	Angle: 21°
Operating pressure	0.49 - 0.83 MPa (70 - 120 PSI)
Magazine capacity	64 - 73
Driving stroke	126 mm (5")
Cylinder bore diameter	57 mm (2-1/4")
Dimensions (L x W x H)	560 x 117 x 348 mm (22 x 4-5/8 x 13-3/4")
Net weight	3.8 kg (8.3 lbs.)



Cordless Concrete Nailer GN420C

7.2V













Capacity	Length: 15 - 40 mm (5/8 - 1-9/16") Dia.: 2.6 - 3.1 mm (0.102 - 0.122")
Magazine capacity	20
Dimensions (L x W x H)	315 x 108 x 390 mm (12-3/8 x 4-1/4 x 15-3/8")
Net weight	3.6 - 3.8 kg (7.9 - 8.3 lbs.)



PRODUCTS

Cleaning



-  Double Insulation
-  Variable Speed
-  Reversing
-  Anti-restart function
-  Electronic 2-Speed
-  Electronic 3-Speed
-  Electronic 4-Speed
-  Constant Speed
-  Soft Start
-  Stainless Tank
-  Revolving Hose
-  Static Free Hose
-  Dust Collection
-  Toolless blade change
-  Built-in Job Light
-  Carrying Case

Cleaning

Cordless Vacuum Cleaner VC006GM

40V max x2



Max sealed suction	18 kPa
Max air flow	at Hose end, w/ Hose 38-2.5: 3.7 m ³ /min
Capacity	Dust / Water: 40 / 30 L
Continuous use	w/ BL4050F, at dial Min: 80 min. w/ BL4050F, at dial Max: 25 min.
Dimensions (L x W x H)	586 x 385 x 598 mm (23 x 15-1/8 x 23-1/2")
Net weight	18.4 - 20.8 kg (40.6 - 45.9 lbs.)

XGT MOTOR AWS XPT



Cordless Vacuum Cleaner VC004GL

40V max



Max sealed suction	23 kPa
Max air flow	at Hose end, w/ BL4050F, w/ ø28 x 3.5 m hose: 1.8 m ³ /min, at Turbine, w/ BL4050F: 4.2 m ³ /min
Capacity	Dust: 15 L
Continuous use	w/ BL4050F at Dial 1: 220 min. w/ BL4050F at Dial 5: 28 min.
Dimensions (L x W x H)	366 x 334 x 475 mm (14-3/8 x 13-1/8 x 18-3/4")
Net weight	8.6 - 11.7 kg (19.0 - 25.8 lbs.)

XGT MOTOR AWS XPT HEPA filter



Cordless Vacuum Cleaner VC002GL

40V max



Max sealed suction	23 kPa
Max air flow	at Hose end, w/ BL4050F, w/ ø28 x 3.5 m hose: 1.8 m ³ /min, at Turbine, w/ BL4050F: 4.2 m ³ /min
Capacity	Dust: 8 L
Continuous use	w/ BL4050F at Dial 1: 220 min. w/ BL4050F at Dial 5: 28 min.
Dimensions (L x W x H)	366 x 334 x 425 mm (14-3/8 x 13-1/8 x 16-3/4")
Net weight	8.3 - 11.4 kg (18.3 - 25.1 lbs.)

XGT MOTOR AWS XPT HEPA filter



Cordless Vacuum Cleaner VC005GL

40V max



Max sealed suction	23 kPa
Max air flow	at Hose end, w/ BL4050F, w/ ø32 x 1.7 m hose: 2.8 m ³ /min, at Turbine, w/ BL4050F: 4.2 m ³ /min
Capacity	Dust: 8 L
Continuous use	w/ BL4050F at Dial 1: 220 min. w/ BL4050F at Dial 5: 28 min.
Dimensions (L x W x H)	366 x 334 x 397 mm (14-3/8 x 13-1/8 x 15-5/8")
Net weight	7.9 - 11.0 kg (17.4 - 24.3 lbs.)

XGT MOTOR XPT



Cordless Vacuum Cleaner DVC156L

18V x2



Max sealed suction	11 kPa
Max air flow	at Hose end, at dial 1, w/ ø28 x 3.5 m hose: 1.0 m ³ /min, at Hose end, at dial 5, w/ ø32 x 1.7 m hose: 2.1 m ³ /min, at Hose end, at dial 5, w/ ø28 x 3.5 m hose: 1.4 m ³ /min, at Turbine: 3.4 m ³ /min
Capacity	Dust: 15 L
Continuous use	w/ BL1860B: 100 min.
Dimensions (L x W x H)	366 x 334 x 421 mm (14-3/8 x 13-1/8 x 16-1/2")
Net weight	7.3 - 7.9 kg (16.1 - 17.4 lbs.)

LXI MOTOR XPT



Cordless Vacuum Cleaner VC007GL

40V max x2



Max sealed suction	18 kPa
Max air flow	at Hose end, w/ Hose 38-2.5: 3.7 m ³ /min
Capacity	Dust / Water: 40 / 30 L
Continuous use	w/ BL4050F, at dial Min: 80 min. w/ BL4050F, at dial Max: 25 min.
Dimensions (L x W x H)	586 x 385 x 598 mm (23 x 15-1/8 x 23-1/2")
Net weight	18.3 - 20.7 kg (40.3 - 45.6 lbs.)

XGT MOTOR AWS XPT HEPA filter



Cordless Vacuum Cleaner VC003GL

40V max



Max sealed suction	23 kPa
Max air flow	at Hose end, w/ BL4050F, w/ ø38 x 2.5 m hose: 3.2 m ³ /min, at Hose end, w/ BL4050F, w/ ø32 x 1.7 m hose: 2.8 m ³ /min, at Turbine, w/ BL4050F: 4.2 m ³ /min
Capacity	Dust / Water: 15 / 12 L
Continuous use	w/ BL4050F at Dial 1: 220 min. w/ BL4050F at Dial 5: 28 min.
Dimensions (L x W x H)	366 x 334 x 475 mm (14-3/8 x 13-1/8 x 18-3/4")
Net weight	8.4 - 11.5 kg (18.5 - 25.4 lbs.)

XGT MOTOR XPT



Cordless Vacuum Cleaner VC001GL

40V max



Max sealed suction	23 kPa
Max air flow	at Hose end, w/ BL4050F, w/ ø38 x 2.5 m hose: 3.2 m ³ /min, at Hose end, w/ BL4050F, w/ ø32 x 1.7 m hose: 2.8 m ³ /min, at Turbine, w/ BL4050F: 4.2 m ³ /min
Capacity	Dust / Water: 8 / 6 L
Continuous use	w/ BL4050F at Dial 1: 220 min. w/ BL4050F at Dial 5: 28 min.
Dimensions (L x W x H)	366 x 334 x 425 mm (14-3/8 x 13-1/8 x 16-3/4")
Net weight	8.1 - 11.2 kg (17.9 - 24.7 lbs.)

XGT MOTOR XPT



Cordless Vacuum Cleaner DVC157L

18V x2



Max sealed suction	11 kPa
Max air flow	at Hose end, at dial 1, w/ ø28 x 3.5 m hose: 1.1 m ³ /min, at Hose end, at dial 5, w/ ø28 x 3.5 m hose: 1.4 m ³ /min, at Turbine: 3.4 m ³ /min
Capacity	Dust: 15 L
Continuous use	w/ BL1860B: 100 min.
Dimensions (L x W x H)	366 x 334 x 421 mm (14-3/8 x 13-1/8 x 16-1/2")
Net weight	8.0 - 8.6 kg (17.6 - 19.0 lbs.)

LXI MOTOR AWS XPT HEPA filter



Cordless Vacuum Cleaner DVC155L

18V x2



Max sealed suction	11 kPa
Max air flow	at Hose end, at dial 1, w/ ø32 x 1.7 m hose: 1.5 m ³ /min, at Hose end, at dial 5, w/ ø32 x 1.7 m hose: 2.1 m ³ /min, at Turbine: 3.4 m ³ /min
Capacity	Dust / Water: 15 / 12 L
Continuous use	w/ BL1860B: 100 min.
Dimensions (L x W x H)	366 x 334 x 421 mm (14-3/8 x 13-1/8 x 16-1/2")
Net weight	7.2 - 7.9 kg (15.9 - 17.4 lbs.)

LXI MOTOR XPT



Cordless Vacuum Cleaner DVC867L

18V x2



Max sealed suction	11 kPa
Max air flow	at Hose end, at dial 1, w/ ø28 x 3.5 m hose: 1.1 m³/min, at Hose end, at dial 5, w/ ø32 x 3.5 m hose: 1.4 m³/min, at Turbine: 3.4 m³/min
Capacity	Dust: 8L
Continuous use	w/ BL1860B: 100 min.
Dimensions (L x W x H)	366 x 334 x 368 mm (14-3/8 x 13-1/8 x 14-1/2")
Net weight	7.7 - 8.4 kg (17.0 - 18.5 lbs.)

LXI BL MOTOR AWS XPT HEPA filter



Cordless Vacuum Cleaner DVC866L

18V x2



Max sealed suction	11 kPa
Max air flow	at Hose end, at dial 1, w/ ø32 x 1.7 m hose: 1.5 m³/min, at Hose end, at dial 5, w/ ø32 x 1.7 m hose: 2.1 m³/min, at Turbine: 3.4 m³/min
Capacity	Dust: 8 L
Continuous use	w/ BL1860B: 100 min.
Dimensions (L x W x H)	366 x 334 x 368 mm (14-3/8 x 13-1/8 x 14-1/2")
Net weight	7.0 - 7.7 kg (15.4 - 17.0 lbs.)

LXI BL MOTOR XPT



Cordless Vacuum Cleaner DVC865L

18V x2



Max sealed suction	11 kPa
Max air flow	at Hose end, at dial 1, w/ ø32 x 1.7 m hose: 1.5 m³/min, at Hose end, at dial 5, w/ ø32 x 1.7 m hose: 2.1 m³/min, at Turbine: 3.4 m³/min
Capacity	Dust / Water: 8 / 6 L
Continuous use	w/ BL1860B: 100 min.
Dimensions (L x W x H)	366 x 334 x 368 mm (14-3/8 x 13-1/8 x 14-1/2")
Net weight	7.0 - 7.7 kg (15.4 - 17.0 lbs.)

LXI BL MOTOR XPT



Corded and Cordless Vacuum Cleaner DVC861L

18V x2



Max sealed suction	AC / DC: 24 / 9 kPa
Max air flow	AC / DC: 3.6 / 2.1 m³/min
Capacity	Dust: 8 L
Continuous use	w/ BL1850B x2: 65 min.
Dimensions (L x W x H)	366 x 334 x 368 mm (14-3/8 x 13-1/8 x 14-1/2")
Net weight	9.3 - 9.9 kg (20.5 - 21.8 lbs.)

LXI DC AG HEPA filter CHIMPALY



Corded and Cordless Vacuum Cleaner DVC860L

18V x2



Max sealed suction	AC / DC: 24 / 9 kPa
Max air flow	AC / DC: 3.6 / 2.1 m³/min
Capacity	Dust / Water: 8 / 6 L
Continuous use	w/ BL1850B x2: 65 min.
Dimensions (L x W x H)	366 x 334 x 368 mm (14-3/8 x 13-1/8 x 14-1/2")
Net weight	8.6 - 9.2 kg (19 - 20.3 lbs.)

LXI DC AG



Vacuum Cleaner VC3211H

18V x2



Continuous rating Input	1,050W
Max sealed suction	22.0 kPa (2,240 mmH ₂ O) (water column)
Max peak air flow	2 m³/min
Tank capacity	Dry: 32 L Wet: 27 L
Dimensions (L x W x H)	552 x 398 x 685 mm (21-3/4 x 15-5/8 x 27")
Net weight	16.9 kg (37.3 lbs.)

CHIMPALY



Vacuum Cleaner VC3211M

18V x2



Continuous rating Input	1,050W
Max sealed suction	22.0 kPa (2,240 mmH ₂ O) (water column)
Max peak air flow	2.0 m³/min
Tank capacity	Dry: 32 L Wet: 27 L
Dimensions (L x W x H)	552 x 398 x 685 mm (21-3/4 x 15-5/8 x 27")
Net weight	16.9 kg (37.3 lbs.)

CHIMPALY



Vacuum Cleaner VC3210L

18V x2



Continuous rating Input	1,050W
Max sealed suction	22.0 kPa (2,240 mmH ₂ O) (water column)
Max peak air flow	2.0 m³/min
Tank capacity	Dry: 32 L Wet: 27 L
Dimensions (L x W x H)	552 x 398 x 685 mm (21-3/4 x 15-5/8 x 27")
Net weight	14.5 kg (32 lbs.)

CHIMPALY



Vacuum Cleaner VC2201M

18V x2



Continuous rating Input	1,050W
Max sealed suction	22.0 kPa (2,240 mmH ₂ O) (water column)
Max peak air flow	2.0 m³/min
Tank capacity	Dry: 22 L Wet: 17 L
Dimensions (L x W x H)	552 x 398 x 569 mm (21-3/4 x 15-5/8 x 22-3/8")
Net weight	16 kg (35.4 lbs.)

CHIMPALY



Vacuum Cleaner VC2211M

18V x2



Continuous rating Input	1,050W
Max sealed suction	22.0 kPa (2,240 mmH ₂ O) (water column)
Max peak air flow	2.0 m³/min
Tank capacity	Dry: 22 L Wet: 17 L
Dimensions (L x W x H)	552 x 398 x 569 mm (21-3/4 x 15-5/8 x 22-3/8")
Net weight	16.3 kg (35.9 lbs.)

CHIMPALY



Cleaning

Vacuum Cleaner VC2510L



Continuous rating Input	1,050W
Max sealed suction (water column)	22.0 kPa (2,240 mmH ₂ O)
Max peak air flow	2.0 m ³ /min
Tank capacity	Dry: 25 L Wet: 14 L
Dimensions (L x W x H)	432 x 416 x 451 mm (17 x 16-3/8 x 17-3/4")
Net weight	10.5 kg (23.2 lbs.)



Vacuum Cleaner VC1310L



Continuous rating Input	1,050W
Max sealed suction (water column)	22.0 kPa (2,240 mmH ₂ O)
Max peak air flow	2.0 m ³ /min
Tank capacity	Dry: 13 L Wet: 7 L
Dimensions (L x W x H)	366 x 334 x 420 mm (14-3/8 x 13-1/8 x 16-1/2")
Net weight	9.6 kg (21.2 lbs.)



Vacuum Cleaner VC4210M



Continuous rating Input	1,200W
Max sealed suction	25.0 kPa
Max peak air flow	4.5 m ³ /min
Tank capacity	Dry: 34 L Wet: 30 L
Dimensions (L x W x H)	565 x 385 x 605 mm
Net weight	16 kg (35.3 lbs.)



Vacuum Cleaner VC4210L



Continuous rating Input	1,200W
Max sealed suction	25.0 kPa
Max peak air flow	4.5 m ³ /min
Tank capacity	Dry: 34 L Wet: 30 L
Dimensions (L x W x H)	565 x 385 x 605 mm
Net weight	16 kg (35.3 lbs.)



Vacuum Cleaner VC3012M



Continuous rating Input	1,500W
Max sealed suction	25.0 kPa
Max peak air flow	3.7 m ³ /min
Tank capacity	Dry: 24 L Wet: 19 L
Dimensions (L x W x H)	450 x 380 x 595 mm
Net weight	11 kg (25.3 lbs.)



Vacuum Cleaner VC3012L



Continuous rating Input	1,500W
Max sealed suction	25.0 kPa
Max peak air flow	3.7 m ³ /min
Tank capacity	Dry: 24 L Wet: 19 L
Dimensions (L x W x H)	450 x 380 x 595 mm
Net weight	11 kg (25.3 lbs.)



Vacuum Cleaner VC3011L



Continuous rating Input	1,000W
Max sealed suction	21.0 kPa
Max peak air flow	3.6 m ³ /min
Tank capacity	Dry: 26 L Wet: 23 L
Dimensions (L x W x H)	390 x 400 x 635 mm
Net weight	9 kg (19.9 lbs.)



Vacuum Cleaner VC2512L



Continuous rating Input	1,000W
Max sealed suction	21.0 kPa
Max peak air flow	3.6 m ³ /min
Tank capacity	Dry: 21 L Wet: 18 L
Dimensions (L x W x H)	390 x 390 x 530 mm
Net weight	7 kg (15.5 lbs.)



Vacuum Cleaner VC2012L



Continuous rating Input	1,000W
Max sealed suction	21.0 kPa
Max peak air flow	3.6 m ³ /min
Tank capacity	Dry: 15 L Wet: 12 L
Dimensions (L x W x H)	371 x 390 x 495 mm
Net weight	7 kg (15.5 lbs.)



Vacuum Cleaner VC2000L



Continuous rating Input	1,000W
Max sealed suction	21.0 kPa
Tank capacity	20 L
Dimensions (L x W x H)	390 x 385 x 505 mm
Net weight	7.5 kg



Cordless Portable Vacuum Cleaner DVC750L

18V



Max sealed suction	High / Normal: 6.7 / 4.2 kPa
Max air flow	at Hose end, High: 1.6 m ³ /min, at Turbine: 2.4 m ³ /min
Capacity	Dust / Water: 7.5 / 4.5 L
Continuous use	w/ BL1850B, High: 30 min. w/ BL1850B, Normal: 60 min.
Dimensions (L x W x H)	418 x 251 x 278 mm (16-1/2 x 9-7/8 x 11")
Net weight	4.3 - 4.6 kg (9.4 - 10.1 lbs.)

LXI BL MOTOR XPT HEPA filter



Cordless Vacuum Cleaner DVC350

18V



Max sealed suction (water column)	6.0 kPa (612 mmH ₂ O)
Max air flow	3.4 m ³ /min
Continuous use	w/ BL1830B, High: 13 min. w/ BL1830B, Low: 26 min.
Dimensions (L x W x H)	273 x 195 x 226 mm (10-3/4 x 7-5/8 x 8-7/8")
Net weight	2.2 - 2.4 kg (4.8 - 5.3 lbs.)

LXI



Cordless Backpack Vacuum Cleaner VC012G

40V max



Max sealed suction	20 kPa
Max air flow	2.1 m ³ /min
Capacity	Paper dust bag: 6.0 L Cloth dust bag: 5.5 L
Continuous use	w/ BL4050F x2, Mode 3: 40 min. w/ BL4050F x2, Mode 2: 75 min. w/ BL4050F x2, Mode 1: 130 min.
Dimensions (L x W x H)	w/ BL4040 x2: 301 x 185 x 526 mm (11-7/8 x 7-1/4 x 20-3/4")
Net weight	6.4 - 9.5 kg (14.1 - 20.9 lbs.)

XGT BL MOTOR AWS HEPA filter



Cordless Backpack Vacuum Cleaner VC011G

40V max



Max sealed suction	20 kPa
Max air flow	2.4 m ³ /min
Capacity	Paper dust bag: 6.0 L Cloth dust bag: 5.5 L
Continuous use	w/ BL4050F x2, Mode 4: 40 min. w/ BL4050F x2, Mode 3: 75 min. w/ BL4050F x2, Mode 2: 130 min. w/ BL4050F x2, Mode 1: 260 min.
Dimensions (L x W x H)	w/ BL4040 x2: 301 x 185 x 526 mm (11-7/8 x 7-1/4 x 20-3/4")
Net weight	6.4 - 9.5 kg (14.1 - 20.9 lbs.)

XGT BL MOTOR HEPA filter



Cordless Backpack Vacuum Cleaner VC009G

40V max



Max sealed suction	18 kPa
Max air flow	1.9 m ³ /min
Capacity	Paper dust bag: 2.0 L Cloth dust bag: 1.5 L
Continuous use	w/ BL4050F, Mode 3: 14 min. w/ BL4050F, Mode 2: 30 min. w/ BL4050F, Mode 1: 55 min.
Dimensions (L x W x H)	w/ BL4080F: 233 x 158 x 413 mm (9-1/8 x 6-1/4 x 16-1/4")
Net weight	4.1 - 5.3 kg (9.0 - 11.7 lbs.)

XGT BL MOTOR AWS HEPA filter



Cordless Backpack Vacuum Cleaner VC008G

40V max



Max sealed suction	18 kPa
Max air flow	2.4 m ³ /min
Capacity	Paper dust bag: 2.0 L Cloth dust bag: 1.5 L
Continuous use	w/ BL4050F, Mode 4: 14 min. w/ BL4050F, Mode 3: 30 min. w/ BL4050F, Mode 2: 55 min. w/ BL4050F, Mode 1: 110 min.
Dimensions (L x W x H)	w/ BL4080F: 233 x 158 x 413 mm (9-1/8 x 6-1/4 x 16-1/4")
Net weight	4.1 - 5.3 kg (9.0 - 11.7 lbs.)

XGT BL MOTOR HEPA filter



Cordless Backpack Vacuum Cleaner DVC665

18V x2



Max sealed suction	11 kPa
Max air flow	w/ Hose 28-1.5: 1.8 m ³ /min
Capacity	Paper dust bag: 6 L Cloth dust bag: 5.5 L
Continuous use	w/ BL1860B, Max: 40 min. w/ BL1860B, High: 75 min. w/ BL1860B, Normal: 140 min.
Dimensions (L x W x H)	297 x 174 x 523 mm (11-3/4 x 6-7/8 x 20-5/8")
Net weight	6.1 - 6.7 kg (13.5 - 14.9 lbs.)

LXI BL MOTOR AWS HEPA filter



Cordless Backpack Vacuum Cleaner DVC660

18V x2



Max sealed suction	11 kPa
Max air flow	w/ Hose 38-1.5: 2.3 m ³ /min w/ Hose 32-1.0: 2.2 m ³ /min w/ Hose 28-1.0: 2.0 m ³ /min w/ Hose 28-1.5: 1.8 m ³ /min
Capacity	Paper dust bag: 6 L Cloth dust bag: 5.5 L
Continuous use	w/ BL1860B, Max: 40 min. w/ BL1860B, High: 75 min. w/ BL1860B, Normal: 140 min.
Dimensions (L x W x H)	297 x 174 x 523 mm (11-3/4 x 6-7/8 x 20-5/8")
Net weight	6.1 - 6.7 kg (13.4 - 14.8 lbs.)

LXI BL MOTOR HEPA filter



Cordless Backpack Vacuum Cleaner DVC265

18V x2



Max sealed suction	11 kPa
Max air flow	w/ Hose 28-1.0: 2 m ³ /min w/ Hose 28-1.5: 1.8 m ³ /min
Capacity	Paper dust bag: 2 L Cloth dust bag: 1.5 L
Continuous use	w/ BL1860B, High: 40 min. w/ BL1860B, Low: 75 min.
Dimensions (L x W x H)	230 x 152 x 373 mm (9 x 6 x 14-3/4")
Net weight	3.9 - 4.5 kg (8.6 - 10.0 lbs.)

LXI BL MOTOR AWS HEPA filter



Cordless Backpack Vacuum Cleaner DVC261

18V x2



Max sealed suction	11 kPa
Max air flow	w/ Hose 38-1.5: 2.3 m ³ /min w/ Hose 32-1.0: 2.2 m ³ /min w/ Hose 28-1.0: 2.0 m ³ /min w/ Hose 28-1.5: 1.8 m ³ /min
Capacity	Paper dust bag: 2.0 L Cloth dust bag: 1.5 L
Continuous use	w/ BL1860B, Max: 40 min. w/ BL1860B, High: 75 min. w/ BL1860B, Normal: 140 min.
Dimensions (L x W x H)	230 x 152 x 373 mm (9 x 6 x 14-3/4")
Net weight	3.8 - 4.5 kg (8.5 - 9.9 lbs.)

LXI BL MOTOR HEPA filter



Comparison List

Model No.	Dust class	Powered	Tank capacity Dust/ Water (L)	Tank type	Max Air Flow (m ³ / min)	Max Sealed Suction (kPa)	Switch of connected power tool
Cordless Vacuum Cleaner / Vacuum Cleaner							
VC006GM	M	DC (40Vmax x2)	40 / 30	Plastic	3.7 (hose Ø 38-2.5)	18	AWS
VC007GL	L (HEPA filter)	DC (40Vmax x2)	40 / 30	Plastic	3.7 (hose Ø 38-2.5)	18	AWS
VC005GL	L	DC (40Vmax)	8 / -	Plastic	2.8 (hose Ø 32-1.7)	23	-
VC004GL	L (HEPA filter)	DC (40Vmax)	15 / -	Plastic	1.8 (hose Ø 28-3.5)	23	AWS
VC003GL	L	DC (40Vmax)	15 / 12	Plastic	3.2 (hose Ø 38-2.5)	23	-
VC002GL	L (HEPA filter)	DC (40Vmax)	8 / -	Plastic	1.8 (hose Ø 28-3.5)	23	AWS
VC001GL	L	DC (40Vmax)	8 / 6	Plastic	3.2 (hose Ø 38-2.5)	23	-
DVC157L	L (HEPA filter)	DC (LXT18V x2)	15 / -	Plastic	2.4 (hose Ø 38-2.5)	11	AWS
DVC156L	L	DC (LXT18V x2)	15 / -	Plastic	2.1 (hose Ø 32-1.7)	11	-
DVC155L	L	DC (LXT18V x2)	15 / 12	Plastic	2.1 (hose Ø 32-1.7)	11	-
DVC867L	L (HEPA filter)	DC (LXT18V x2)	8 / -	Plastic	2.4 (hose Ø 38-2.5)	11	AWS
DVC866L	L	DC (LXT18V x2)	8 / -	Plastic	2.1 (hose Ø 32-1.7)	11	-
DVC865L	L	DC (LXT18V x2)	8 / 6	Plastic	2.1 (hose Ø 32-1.7)	11	-
DVC861L	L (HEPA filter)	DC (LXT18V x2) / AC	8 / -	Plastic	AC/DC : 3.6 / 2.1 (Ø 38-2.5)	AC/DC : 24 / 9.0	-
DVC860L	L	DC (LXT18V x2) / AC	8 / 6	Plastic	AC/DC : 3.6 / 2.1 (Ø 38-2.5)	AC/DC : 24 / 9.0	-
VC3211H	H	AC	32 / 27	Stainless steel	2.0 (hose Ø 28-3.5)	22	Automatic
VC3211M	M	AC	32 / 27	Stainless steel	2.0 (hose Ø 28-3.5)	22	Automatic
VC3210L	L	AC	32 / 27	Stainless steel	2.0 (hose Ø 28-3.5)	22	Automatic
VC2201M	M	AC	22 / 17	Stainless steel	2.0 (hose Ø 28-3.5)	22	-
VC2211M	M	AC	22 / 17	Stainless steel	2.0 (hose Ø 28-3.5)	22	Automatic
VC2510L	L	AC	25 / 14	Plastic	2.0 (hose Ø 28-3.5)	22	Automatic
VC1310L	L	AC	13 / 7	Plastic	2.0 (hose Ø 28-3.5)	22	Automatic
VC4210M	M	AC	34 / 30	Plastic	4.5	25	Automatic
VC4210L	L	AC	34 / 30	Plastic	4.5	25	Automatic
VC3012M	M	AC	24 / 19	Plastic	3.7	25	Automatic
VC3012L	L	AC	24 / 19	Plastic	3.7	25	Automatic
VC3011L	L	AC	26 / 23	Stainless steel	3.6	21	Automatic
VC2512L	L	AC	21 / 18	Plastic	3.6	21	Automatic
VC2012L	L	AC	15 / 12	Stainless steel	3.6	21	Automatic
VC2000L	L	AC	20 / -	Plastic	-	21	-
DVC350	-	DC (LXT18V)	3 / -	-	3.4	6	-
DVC750L	L (HEPA filter)	DC (LXT18V)	7.5 / 4.5	Plastic	1.6	6.7	-
Cordless Backpack Vacuum Cleaner							
VC012G	(HEPA filter)	DC (40Vmax)	Paper dust bag 6.0 / - Cloth dust bag 5.5	-	2.1	20	AWS
VC011G	(HEPA filter)	DC (40Vmax)	Paper Dust bag 6.0 / - Cloth Dust bag 5.5	-	2.4	20	-
VC009G	(HEPA filter)	DC (40Vmax)	Paper dust bag: 2.0 / - Cloth Dust Bag 1.5	-	1.9 (hose Ø 28-1.5)	18	AWS
VC008G	(HEPA filter)	DC (40Vmax)	Paper dust bag: 2.0 / - Cloth Dust Bag 1.5	-	2.4 (hose Ø 32-1.0)	18	-
DVC665	(HEPA filter)	DC (LXT18V x2)	Paper dust bag 6.0 / - Cloth dust bag 5.5	-	1.8 (hose Ø 28-1.5)	11	AWS
DVC660	(HEPA filter)	DC (LXT18V x2)	Paper dust bag 6.0 / - Cloth dust bag 5.5	-	2.2 (hose Ø 32-1.0)	11	-
DVC265	(HEPA filter)	DC (LXT18V x2)	Paper dust bag 2.0 / - Cloth dust bag 1.5	-	2.0 (hose Ø 28-1.0)	11	AWS
DVC261	(HEPA filter)	DC (LXT18V x2)	Paper dust bag 2.0 / - Cloth dust bag 1.5	-	2.2 (hose Ø 32-1.0)	11	-
Cordless Upright Cleaner							
VC010G	L(HEPA filter)	DC (40Vmax)	5 / -	-	1.8	15	-
DVC560	L(HEPA filter)	DC (LXT18V x2)	5 / -	-	1.9	12	-

Cleaning

Cordless Cyclone Cleaner DCL501

18V



Max sealed suction (water column)	10 kPa (1,020 mmH ₂ O)
Max air flow	1.2 m ³ /min
Capacity	250 mL
Continuous use	w/ BL1860B (High): 35 min. w/ BL1860B (Low): 77 min.
Dimensions (L x W x H)	352 x 189 x 252 mm (13-7/8 x 7-7/16 x 9-7/8")
Net weight	3.1 - 3.4 kg (6.8 - 7.5 lbs.)

LXT BL MOTOR HEPA filter



Robotic Cleaner DRC300

18V



Max cleaning area	w/ BL1860B x2: 600 m ²
Continuous use	w/ BL1860B x2: 240 min. 10,000 m ²
Max registrable mapping area	
Rotation speed	Main brush: 1,600 RPM Side brush: 200 RPM
Max running speed	0.3 m/sec
Dust box capacity	3.0 L
Dimensions (L x W x H)	500 x 500 x 204 mm (19-3/4 x 19-3/4 x 8")
Net weight	9.6 - 10.6 kg (21.2 - 23.4 lbs.)

LXT BL MOTOR HEPA filter



Robotic Cleaner DRC200

18V



Max cleaning area	w/ BL1850B x2: 500 m ²
Continuous use	w/ BL1850B x2: 200 min.
Max running speed	0.3 m/sec
Dust box capacity	2.5 L
Dimensions (L x W x H)	460 x 460 x 180 mm (18-1/8 x 18-1/8 x 7-1/8")
Net weight	7.8 kg (16.1 lbs.)

LXT BL MOTOR

Cordless Upright Cleaner VC010G

40V max



Max sealed suction	15 kPa
Max air flow	1.8 m ³ /min
Capacity	5.0 L (1.3 gal)
Cleaning width	381 mm (15")
Continuous use	w/ BL4050F, High / Normal / Low noise: 25 / 50 / 100 min.
Dimensions (L x W x H)	326 x 381 x 1,146 mm (12-7/8 x 15 x 45")
Net weight	8.0 - 9.2 kg (17.6 - 20.3 lbs.)

XGT BL MOTOR HEPA filter



Cordless Upright Cleaner DVC560

18V x2



Max sealed suction	12 kPa
Max air flow	1.9 m ³ /min
Capacity	Dust: 5 L
Cleaning width	318 mm (12-1/2")
Continuous use	w/ BL1860B x2 High / Normal / Low noise: 30 / 60 / 120 min.
Dimensions (L x W x H)	326 x 318 x 1,146 mm (12-7/8 x 12-1/2 x 45")
Net weight	8.3 - 9.0 kg (18.3 - 19.8 lbs.)

LXT BL MOTOR HEPA filter



Cordless Cleaner DCL184

18V



Max sealed suction	5.4 kPa (550 mmH ₂ O)
Max air flow	Cleaning: 1.4 m ³ /min Blowing: 0.4 m ³ /min
Max air velocity	Blowing: 100 m/s
Continuous use	w/ BL1830B, Max / High / Normal: 20 / 30 / 80 min.
Dimensions (L x W x H)	w/ BL1830B / BL1840B / BL1850B / BL1860B: 365 x 138 x 202 mm (14-3/8 x 5-7/16 x 8")
Net weight	1.8 - 2.2 kg (4.0 - 4.9 lbs.)

LXT



Cordless Cleaner CL121D

12V max



Max sealed suction	4.6 kPa (470 mmH ₂ O)
Max air flow	Cleaning: 1.3 m ³ /min Blowing: 0.3 m ³ /min
Max air velocity	Blowing: 76 m/s
Continuous use	w/ BL1016, Max / High / Normal: 10 / 12 / 25 min. w/ BL1041B, Max / High / Normal: 27 / 32 / 67 min.
Dimensions (L x W x H)	w/ BL1041B: 359 x 138 x 202 mm (14-1/8 x 5-7/16 x 8")
Net weight	1.7 - 1.8 kg (3.7 - 4.0 lbs.)

CXT



Cordless Vacuum Sweeper VS001G

40V max



Cleaning width	Main brush: 480 mm (18-7/8") Side brush: 650 mm (25-1/2")
Dust container capacity	24 L (6.3 gal)
Dust collection volume	15.6 L (4.1 gal)
Dust bag capacity	47 L (12.4 gal) (Optional accessory)
Continuous use	Quiet: 290, 480 min./ Standard: 120, 200 min.
Dimensions (L x W x H)	w/ Handle in upright position: 830 x 677 x 1,146 mm (32-3/4 x 26-3/4 x 45")
Net weight	29.9 - 33.1 kg (65.9 - 73.0 lbs.)

XGT BL MOTOR XPT HEPA filter

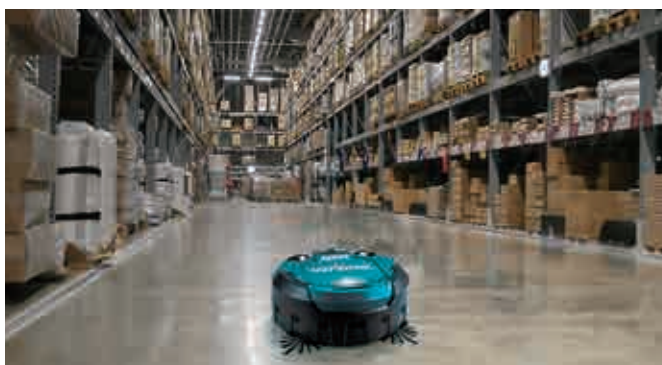

Cleaning

Capsule type



One touch switch



CL001G **40Vmax**

Easy shake off dust filter



Max Air Flow **Max Sealed Suction**
1.2m³/min **21kPa**

DCL284F **18V**

Easy shake off dust filter



Max Air Flow **Max Sealed Suction**
1.2m³/min **18kPa**

DCL181F **18V**

Easy shake off dust filter



Max Air Flow **Max Sealed Suction**
1.4m³/min **5.3kPa**

Paper bag type



One touch switch



CL002G **40Vmax**

Easy shake off dust bag



Max Air Flow **Max Sealed Suction**
1.2m³/min **21kPa**

DCL285F **18V**

Easy shake off dust bag



Max Air Flow **Max Sealed Suction**
1.2m³/min **18kPa**

DCL182 **18V**

Easy shake off dust bag



Max Air Flow **Max Sealed Suction**
1.0m³/min **4.0kPa**

Capsule type



Trigger switch



DCL283F **18V**

Easy shake off dust filter

Lock on button



Max Air Flow **Max Sealed Suction**
1.1m³/min **17.5kPa**

DCL180 **18V**

Easy shake off dust filter



Max Air Flow **Max Sealed Suction**
1.4m³/min **4.2kPa**

CL106FD **12Vmax**



Max Air Flow **Max Sealed Suction**
1.3m³/min **3.1kPa**

Cyclone unit



One touch switch



CL003G **40Vmax**

High performance filter set



Max Air Flow **Max Sealed Suction**
1.0m³/min **20kPa**

DCL286F **18V**

High performance filter set



Max Air Flow **Max Sealed Suction**
1.0m³/min **18kPa**

 **CL108FD** 12Vmax



Max Air Flow **Max Sealed Suction**
1.2m³/min **4.4kPa**

 **CL117FD 2.0Ah** 12Vmax
Built-in Battery



Max Air Flow **Max Sealed Suction**
1.0m³/min **5.0kPa**

 **Home**

 **Building**

 **Built-in Job Light**

 **Electronic 2-Speed**

 **Electronic 3-Speed**

 **Electronic 4-Speed**

 **Anti-restart function**

 **CL107FD** 12Vmax



Max Air Flow **Max Sealed Suction**
1.4m³/min **5.0kPa**

 **CL114FD 2.0Ah** 12Vmax
Built-in Battery



Max Air Flow **Max Sealed Suction**
1.4m³/min **5.0kPa**

 **CL102D** 10.8V





Max Air Flow **Max Sealed Suction**
1.1m³/min **2.7kPa**

 **CL072D** 7.2V





Max Air Flow **Max Sealed Suction**
1.1m³/min **2.1kPa**

 **CL100D** 10.8V



Max Air Flow **Max Sealed Suction**
1.3m³/min **2.3kPa**

 **CL070D** 7.2V



Max Air Flow **Max Sealed Suction**
1.2m³/min **2.2kPa**

 **CL183D** 18V



Max Air Flow **Max Sealed Suction**
1.3m³/min **2.6kPa**

Cleaning

Cordless Cleaner

Color

40V
max
XGT

CL001G / CL002G / CL003G



	CL001G	CL002G	CL003G
Max sealed suction	21 kPa (2,100 mmH ₂ O)	21 kPa (2,100 mmH ₂ O)	20 kPa (2,000 mmH ₂ O)
Max air flow	1.2 m ³ /min	1.2 m ³ /min	1.0 m ³ /min
Dust capacity	730 mL (24.7 oz)	Cloth dust bag: 500 mL Paper dust bag: 330 mL	250 mL (8.5 oz)
Continuous use	w/ BL4025, Mode 1 / 2 / 3 / 4: 80 / 40 / 25 / 16 min.	w/ BL4025, Mode 1 / 2 / 3 / 4: 80 / 40 / 25 / 16 min.	w/ BL4025, Mode 1 / 2 / 3 / 4: 80 / 40 / 25 / 16 min.
Dimensions (L x W x H)	w/ BL4040: 1,081 x 113 x 158 mm (42-1/2 x 4-7/16 x 6-1/4")	w/ BL4040: 1,081 x 114 x 158 mm (42-1/2 x 4-1/2 x 6-1/4")	w/ BL4040: 1,121 x 113 x 177 mm (44-1/4 x 4-7/16 x 7")
Net weight	1.7 - 2.3 kg (3.7 - 5.1 lbs.)	1.8 - 3.0 kg (4.0 - 6.6 lbs.)	1.9 - 2.5 kg (4.2 - 5.5 lbs.)

18V

LXT

Fast Charging

DCL283F / DCL284F / DCL285F / DCL286F



	DCL283F	DCL284F	DCL285F	DCL286F
Max sealed suction	17.5 kPa (1,785 mmH ₂ O)	18 kPa (1,836 mmH ₂ O)	18 kPa (1,836 mmH ₂ O)	18 kPa (1,836 mmH ₂ O)
Max air flow	1.1 m ³ /min	1.2 m ³ /min	1.2 m ³ /min	1.0 m ³ /min
Capacity	730 mL (24.7 oz)	730 mL (24.7 oz)	Cloth dust bag: 500 mL Paper dust bag: 330 mL	250 mL (8.5 oz)
Continuous use	w/ BL1830B: 10 min.	w/ BL1830B, Mode 1 / 2 / 3 / 4: 38 / 21 / 15 / 8 min.	w/ BL1830B, Mode 1 / 2 / 3 / 4: 38 / 21 / 15 / 8 min.	w/ BL1830B, Mode 1 / 2 / 3 / 4: 38 / 21 / 15 / 8 min.
Dimensions (L x W x H)	w/ BL1850B: 503 x 113 x 155 mm (19-3/4 x 4-7/16 x 6-1/8")	w/ BL1850B: 503 x 113 x 153 mm (19-3/4 x 4-7/16 x 6")	w/ BL1850B: 503 x 113 x 153 mm (19-3/4 x 4-7/16 x 6")	w/ BL1850B: 543 x 113 x 177 mm (21-3/8 x 4-7/16 x 7")
Net weight	1.3 - 1.6 kg (2.9 - 3.5 lbs.)	1.3 - 1.6 kg (2.9 - 3.5 lbs.)	1.4 - 1.7 kg (3.1 - 3.7 lbs.)	1.6 - 1.9 kg (3.5 - 4.2 lbs.)

DCL180 / DCL181F / DCL182



	DCL180	DCL181F	DCL182
Max sealed suction	4.2 kPa (428 mmH ₂ O)	5.3 kPa (540 mmH ₂ O)	4.0 kPa (400 mmH ₂ O)
Max air flow	1.4 m ³ /min	1.4 m ³ /min	1.0 m ³ /min
Capacity	650 mL	650 mL	Cloth dust bag: 500 mL Paper dust bag: 330 mL
Continuous use	w/ BL1830B: 20 min.	w/ BL1830B, High / Low: 20 / 40 min.	w/ BL1830B, High / Low: 20 / 40 min.
Dimensions (L x W x H)	999 x 114 x 152 mm (39-1/4 x 4-1/2 x 6")	999 x 114 x 152 mm (39-1/4 x 4-1/2 x 6")	1,004 x 115 x 151 mm (39-1/2 x 4-1/2 x 5-15/16")
Net weight	1.2 kg (2.7 lbs.)	1.2 - 1.4 kg (2.7 - 3.1 lbs.)	1.3 kg (2.9 lbs.)

12V
max

CXT

Fast Charging

CL106FD / CL107FD / CL108FD



	CL106FD	CL107FD	CL108FD
Max sealed suction	3.1 kPa (316 mmH ₂ O)	5.0 kPa (510 mmH ₂ O)	4.4 kPa (445 mmH ₂ O)
Max air flow	1.3 m ³ /min	1.4 m ³ /min	1.2 m ³ /min
Capacity	600 mL	Cloth dust bag: 500 mL Paper dust bag: 330 mL	600 mL
Continuous use	w/ BL1041B: 42 min.	w/ BL1041B, Max / High / Normal: 20 / 24 / 50 min.	w/ BL1016, Max / High / Normal: 10 / 12 / 25 min.
Dimensions (L x W x H)	958 x 100 x 150 mm (37-3/4 x 3-15/16 x 5-7/8")	960 x 112 x 150 mm (37-3/4 x 4-3/8 x 5-7/8")	956 x 110 x 150 mm (37-5/8 x 4-5/16 x 5-7/8")
Net weight	1 - 1.1 kg (2.1 - 2.5 lbs.)	1.1 - 1.3 kg (2.5 - 2.9 lbs.)	1.0 - 1.2 kg (2.2 - 2.6 lbs.)

12V
max

Built-in
Battery

CL114FD / CL117FD



	CL114FD	CL117FD
Max sealed suction	5.0 kPa (510 mmH ₂ O)	5.0 kPa (510 mmH ₂ O)
Max air flow	1.4 m ³ /min	1.0 m ³ /min
Capacity	Cloth dust bag: 500 mL Paper dust bag: 330 mL	650 mL
Continuous use	Powerful / High / Normal: 10 / 18 / 55 min.	Powerful / High / Normal: 10 / 18 / 55 min.
Dimensions (L x W x H)	983 x 113 x 136 mm (38-3/4 x 4-7/16 x 5-3/8")	992 x 110 x 136 mm (39 x 4-5/16 x 5-3/8")
Net weight	1.1 kg (2.4 lbs.)	1.0 kg (2.2 lbs.)

7.2V

10.8V

CL070D / CL072D / CL100D / CL102D



	CL070D	CL072D	CL100D	CL102D
Max sealed suction	2.2 kPa (224 mmH ₂ O)	2.1 kPa (214 mmH ₂ O)	2.3 kPa (235 mmH ₂ O)	2.7 kPa (275 mmH ₂ O)
Max air flow	1.2 m ³ /min	1.1 m ³ /min	1.3 m ³ /min	1.1 m ³ /min
Capacity	600 mL	Cloth dust bag: 500 mL Paper dust bag: 330 mL	600 mL	Cloth dust bag: 500 mL Paper dust bag: 330 mL
Continuous use	8 min.	High / Low : 8 / 16 min.	12 min.	High / Low : 13 / 21 min.
Dimensions (L x W x H)	966 x 103 x 142 mm (38-1/32 x 4-1/16 x 5-5/8")	984 x 113 x 146 mm (38-3/4 x 4-7/16 x 5-3/4")	966 x 103 x 150 mm (38-1/32 x 4-1/16 x 5-7/8")	984 x 113 x 150 mm (38-3/4 x 4-7/16 x 5-7/8")
Net weight	0.81 kg (1.8 lbs.)	1 kg (2.2 lbs.)	0.88 kg (1.94 lbs.)	1.1 kg (2.4 lbs.)

18V

CL183D



	CL183D
Max sealed suction	2.6 kPa (270 mmH ₂ O)
Max air flow	1.3 m ³ /min
Capacity	600 mL
Continuous use	w/ BL1815G: 30 min.
Dimensions (L x W x H)	966 x 102 x 148 mm (38 x 4 x 5-7/8")
Net weight	1.2 kg (2.6 lbs.)

Battery Powered Backpack Blower UB004C



No load speed	Mode 1 / 2 / 3: 10,500 / 18,000 / 22,500 min ⁻¹ Boost mode: 23,800 min ⁻¹
Blowing force	Mode 1 / 2 / 3: 5 / 15 / 25 N Boost mode: 28 N
Air volume	Mode 1 / 2 / 3: 8.5 / 15.2 / 19.7 m ³ /min Boost mode: 20.9 m ³ /min
Max air velocity	Mode 1 / 2 / 3: 33.2 / 59.0 / 76.3 m/s Boost mode: 80.7 m/s
Continuous use	55 - 200 min.
Dimensions (L x W x H)	460 x 575 x 585 mm (18-1/8 x 22-5/8 x 23")
Net weight	16.5 - 18.6 kg (36.4 - 41.0 lbs.)



Battery Powered Blower UB003C



No load speed	Mode1 / Mode2 / Mode3: 4,000 - 10,600 / 17,700 / 22,100 min ⁻¹
Blowing force	w/ End nozzle, w/ PDC1500, Max speed mode: 24 N
Max air volume	w/ End nozzle, Max speed mode: 17.6 m ³ /min
Max air velocity	w/ End nozzle, Max speed mode: 86.0 m/s
Continuous use	w/ End nozzle, Max speed mode: 60 min.
Dimensions (L x W x H)	w/ Nozzle: 913 - 1,013 x 178 x 298 mm (36 - 40 x 7 x 11-3/4")
Net weight	2.8 - 3.1 kg (6.2 - 6.8 lbs.)



Cordless Blower UB001G

40V max



No load speed	Cruise control mode: 0 - 20,000 min ⁻¹ Boost mode: 23,000 min ⁻¹
Blowing force	Cruise control mode: 0 - 12 N Boost mode: 17 N
Max air volume	Cruise control mode: 0 - 13.5 m ³ /min Boost mode: 16.0 m ³ /min
Max air velocity	Cruise control mode: 53 m/s Boost mode: 64 m/s
Continuous use	Cruise control mode, w/ BL4050F: 15 min. Boost mode, w/ BL4050F: 8 min.
Dimensions (L x W x H)	w/ End nozzle 80, w/ BL4050F: 943 - 1,043 x 167 x 297 mm (37-1/8 - 41 x 6-9/16 x 11-3/4")
Net weight	3.1 - 3.9 kg (6.8 - 8.6 lbs.)



Cordless Blower DUB363

18V x2



No load speed	0 - 7,850 min ⁻¹
Blowing force	14.4 N
Max air volume	13.4 m ³ /min (473 CFM)
Dimensions (L x W x H)	w/ 3-stage telescopic long nozzle: 737 x 786 x 836 mm (193 x 415 x 7-7/16") w/ Vacuum nozzle: 1,396 x 604 x 415 mm (55 x 23-3/4 x 16-3/8")
Net weight	4.5 - 6.6 kg (9.9 - 14.6 lbs.)



Cordless Blower DUB362

18V x2



No load speed	11,400 - 21,500 min ⁻¹
Blowing force	14.4 N
Max air volume	13.4 m ³ /min (473 CFM)
Max air velocity	54 m/s (120 MPH)
Dimensions (L x W x H)	w/ 3-stage telescopic long nozzle: 830 x 880 x 930 mm (205 x 295 x 32-3/4")
Net weight	3.5 - 4.2 kg (7.7 - 9.3 lbs.)



Cordless Blower DUB361

18V x2



No load speed	High: 17,000 min ⁻¹ Low: 10,000 min ⁻¹
Max air volume	High: 4.4 m ³ /min (155 CFM) Low: 2.6 m ³ /min (92 CFM)
Max air velocity	High: 93 m/s (208 MPH) Low: 57 m/s (128 MPH)
Dimensions (L x W x H)	905 x 141 x 194 mm (35-5/8 x 5-5/8 x 7-5/8")
Net weight	3.1 - 3.2 kg (6.8 - 7.1 lbs.)



Cordless Blower Vacuum DUB187

18V



No load speed	9,000 - 13,500 min ⁻¹
Max air volume (Blower)	4.2 m ³ /min
Max air volume (Vacuum)	6.1 m ³ /min
Max air velocity (Blower)	64 m/s
Max sealed suction	3.3 kPa
Dust bag capacity	25 L
Continuous use	w/ BL1860B: 14 min.
Dimensions (L x W x H)	1,168 x 164 x 416 mm (46 x 6-1/2 x 16-3/8")
Net weight	3.7 - 4.0 kg (8.2 - 8.8 lbs.)



Cordless Blower DUB184

18V



No load speed	0 - 18,000 min ⁻¹
Blowing force	10.9 N
Max air volume	13.0 m ³ /min (459 CFM)
Max air velocity	52.1 m/s (116 MPH)
Continuous use	w/ BL1860B: 12 min. w/ BL1850B: 10 min.
Dimensions (L x W x H)	w/ BL1830B / BL1840B / BL1850B / BL1860B: 825 x 160 x 285 mm (32-1/2 x 6-5/16 x 11-1/4")
Net weight	2.5 - 3.0 kg (5.4 - 6.7 lbs.)



Cordless Blower DUB185

18V



No load speed	0 - 18,000 min ⁻¹
Blowing force	3.1 N
Max sealed suction	5.8 kPa
Continuous use	w/ BL1850(B), High / Mid / Low: 21 / 50 / 130 min. w/ BL1830(B), High / Mid / Low: 13 / 30 / 80 min.
Dimensions (L x W x H)	w/ BL1830B / BL1840B / BL1850B / BL1860B: 517 x 156 x 210 mm (20-3/8 x 6-1/8 x 8-1/4")
Net weight	1.6 - 2.1 kg (3.5 - 4.6 lbs.)



Cordless Blower DUB186

18V



No load speed	0 - 18,000 min ⁻¹
Blowing force	2.5 N
Continuous use	w/ BL1850(B), High / Mid / Low: 20 / 50 / 130 min. w/ BL1830(B), High / Mid / Low: 12 / 30 / 80 min.
Dimensions (L x W x H)	w/ BL1830B / BL1840B / BL1850B / BL1860B: 861 x 156 x 210 mm (34 x 6-1/8 x 8-1/4")
Net weight	1.6 - 2.1 kg (3.5 - 4.6 lbs.)



Cleaning

Cordless Blower UB100D

12V max



No load speed	0 - 15,800 min ⁻¹
Blowing force	1.8 N
Max sealed suction	4.0 kPa
Continuous use	w/ BL1016, High / Mid / Low: 8 / 20 / 45 min.
Dimensions (L x W x H)	w/ BL1041B: 508 x 155 x 202 mm (20 x 6-1/8 x 8")
Net weight	1.4 - 1.9 kg (3.1 - 4.2 lbs.)



Cordless Blower UB101D

12V max



No load speed	0 - 15,800 min ⁻¹
Blowing force	1.6 N
Continuous use	w/ BL1016, High / Mid / Low: 7 / 20 / 45 min.
Dimensions (L x W x H)	w/ BL1041B: 852 x 155 x 202 mm (33-1/2 x 6-1/8 x 8")
Net weight	1.4 - 1.9 kg (3.1 - 4.2 lbs.)



Blower UB1103



Continuous rating Input	600W
No load speed	0 - 16,000 min ⁻¹
Air pressure	0 - 5.7 kPa
Max air volume	0 - 4.1 m ³ /min
Max air velocity	0 - 91 m/s
Dimensions (L x W x H)	479 x 185 x 178 mm (18-7/8 x 7-1/4 x 7")
Net weight	1.9 - 2.2 kg (4.3 - 4.8 lbs.)



Blower UB1102



Continuous rating Input	600W
No load speed	16,000 min ⁻¹
Air pressure	5.7 kPa
Max air volume	4.1 m ³ /min
Max air velocity	91 m/s
Dimensions (L x W x H)	479 x 185 x 178 mm (18-7/8 x 7-1/4 x 7")
Net weight	1.9 - 2.2 kg (4.3 - 4.8 lbs.)



Cordless Dust Blower AS001G

40V max



Blowing force	Mode 1: 0 - 1.1 N Mode 4: 0 - 2.8 N
Air pressure	0 - 29.7 kPa
Air volume	0 - 1.1 m ³ /min
Air velocity	0 - 200 m/s
Max sealed suction	10.3 kPa
Continuous use	w/ BL4025, Mode 1: 50 min. w/ BL4025, Mode 2: 25 min. w/ BL4025, Mode 3: 17 min. w/ BL4025, Mode 4: 13 min.
Dimensions (L x W x H)	w/ BL4050F: 182 x 94 x 332 mm (7-1/8 x 3-11/16 x 13-1/8")
Net weight	1.5 - 2.3 kg (3.3 - 5.1 lbs.)



Cordless Dust Blower DAS180

18V



Blowing force	Mode 1: 0 - 1.1 N / Mode 4: 0 - 2.8 N
Air pressure	0 - 29.7 kPa
Air volume	0 - 1.1 m ³ /min
Air velocity	0 - 200 m/s
Max sealed suction	10.3 kPa
Continuous use	w/ BL1860B, Mode 1: 55 min. w/ BL1860B, Mode 2: 30 min. w/ BL1860B, Mode 3: 20 min. w/ BL1860B, Mode 4: 15 min.
Dimensions (L x W x H)	w/ BL1830B / BL1840B / BL1850B / BL1860B: 179 x 92 x 297 mm (7 x 3-5/8 x 11-3/4")
Net weight	1.2 - 1.7 kg (2.6 - 3.7 lbs.)



Cordless High Pressure Washer HW001G

40V max



Max permissible pressure	11.5 MPa
Regular flow	Mode 1 / 2 / 3: 3.0 / 4.2 / 5.5 L/min
Max water flow	7.0 L/min
Pump speed	Mode 1 / 2 / 3: 1,870 / 2,580 / 3,350 min ⁻¹
Max feed temperature	40°C
Max suction height	1 m (3.3 ft)
Continuous use	w/ BL4050F x2, Mode 1 / 2 / 3: 60 / 30 / 18 min.
High pressure hose length	5 m (16 ft)
Dimensions (L x W x H)	344 x 383 x 520 mm (13-1/2 x 15-1/8 x 20-1/2")
Net weight	10.3 - 13.4 kg (22.7 - 29.5 lbs.)



Cordless High Pressure Washer DHW080

18V x2



Max permissible pressure	8.0 MPa
Regular flow	High / Low: 330 / 240 L/h (5.5 / 4.0 L/min)
Max water flow	6.3 L/min
Pump speed	High / Low: 3,450 / 2,390 min ⁻¹
Max feed temperature	40°C
Max suction height	1 m (3.3 ft)
Tank	50 L
Continuous use	w/ BL1860B x2, High / Low: 15 / 34 min.
High pressure hose length	5 m (16 ft)
Dimensions (L x W x H)	438 x 218 x 269 mm (17-1/4 x 8-5/8 x 10-5/8")
Net weight	7.1 - 7.7 kg (15.6 - 17.0 lbs.)



High Pressure Washer HW151



Continuous rating Input	2,500W
Max pressure	15 Mpa (150 bar, 2,175 PSI)
Max flow rate	500 L/h
Max feed temperature	50°C (122°F)
High pressure hose length	10 m (33 ft)
Net weight	26.9 kg (59.3 lbs.)

High Pressure Washer HW140



Continuous rating Input	2,300W
Max pressure	14 Mpa (140 bar, 2,030 PSI)
Max flow rate	500 L/h
Max feed temperature	50°C (122°F)
High pressure hose length	10 m (33 ft)
Net weight	29 kg (63.9 lbs.)

High Pressure Washer HW121



Continuous rating Input	2,100W
Max pressure	13 Mpa (130 bar, 1,885 PSI)
Max flow rate	390 L/h
Max feed temperature	50°C (122°F)
High pressure hose length	8 m (26.3 ft)
Net weight	17.8 kg (39.2 lbs.)

High Pressure Washer HW1300



Continuous rating Input	1,800W
Max pressure	13 Mpa (130 bar, 1,885 PSI)
Max flow rate	450 L/h
Max feed temperature	40°C (104°F)
High pressure hose length	10 m (33 ft)
Dimensions (L x W x H)	292 x 358 x 830 mm (11-1/2 x 14-1/8 x 32-3/4")
Net weight	12.7 kg (28 lbs.)



High Pressure Washer HW1200



Continuous rating Input	1,800W
Max pressure	12 Mpa (120 bar, 1,740 PSI)
Max flow rate	420 L/h
Max feed temperature	40°C (104°F)
High pressure hose length	10 m (33 ft)
Dimensions (L x W x H)	292 x 358 x 830 mm (11-1/2 x 14-1/8 x 32-3/4")
Net weight	11 kg (24.3 lbs.)



High Pressure Washer HW111



Continuous rating Input	1,700W
Max pressure	11 Mpa (110 bar, 1,595 PSI)
Max flow rate	370 L/h
Max feed temperature	50°C (122°F)
High pressure hose length	5.5 m (18 ft)
Net weight	7.4 kg (16.3 lbs.)

High Pressure Washer HW112



Continuous rating Input	1,600W
Max pressure	12 Mpa (120 bar, 1,740 PSI)
Max flow rate	370 L/h
Max feed temperature	50°C (122°F)
High pressure hose length	5.5 m (18 ft)
Net weight	16.2 kg (35.7 lbs.)

High Pressure Washer HW102



Continuous rating Input	1,300W
Max pressure	10 Mpa (100 bar, 1,450 PSI)
Max flow rate	360 L/h
Max feed temperature	50°C (122°F)
High pressure hose length	5 m (16.4 ft)
Net weight	5.8 kg (12.8 lbs.)



High Pressure Washer HW101



Continuous rating Input	1,300W
Max pressure	10 Mpa (100 bar, 1,450 PSI)
Max flow rate	360 L/h
Max feed temperature	50°C (122°F)
High pressure hose length	5 m (16.4 ft)
Net weight	6.5 kg (14.3 lbs.)

Cordless Pressure Washer DHW180

18V
new



Regular pressure	Self-priming, High: 2.0 Mpa / Low: 0.8 Mpa Connection to water supply, High: 2.4 Mpa / Low: 0.8 Mpa
Regular flow rate	High: 2.5 L/min / Low: 1.5 L/min w/o Nozzle: 5.3 L/min
Max flow rate	
Continuous use (Battery)	18, 50 min. BL1830B (Mode) High, Low
Max suction height	2.0 m (6.7 ft)
Supplied hose length	6 m (19.7 ft)
Dimensions (L x W x H)	419 x 99 x 239 mm (16-1/2 x 3-7/8 x 9-3/8")
Net weight	2.3 - 2.7 kg (5.1 - 6.0 lbs.)

LXI XPT



Cordless Polisher Scrubber PS001G

40V max

new



No load speed	High: 600 min ⁻¹ Med.: 350 min ⁻¹ Low: 150 min ⁻¹
Continuous use	High: 30 min. Med.: 50 min. Low: 140 min.
(Battery)	BL4025
Telescopic pole	1,081 - 1,435 mm (42-1/2 - 56-1/2")
Head height	189 mm (7-7/16")
Dimensions (L x W x H)	1,081 - 1,435 x 204 x 361 mm (42-1/2 - 56-1/2 x 8 x 14-1/4")
Net weight	4.4 - 5.6 kg (9.7 - 12.3 lbs.)













XGT BL MOTOR XPT



PRODUCTS

Lawn care/Grass care



-  Double Insulation
-  Variable Speed
-  Brake
-  Reversing
-  Reverse function for debris removal
-  Anti-restart function
-  Electronic 2-Speed
-  Electronic 3-Speed
-  Constant Speed
-  Soft Start
-  Toolless blade change
-  Carrying Case

Robotic Mower RM350D



- Keeps the lawn clean at all times without collecting the grass.
- Manages a work area within a boundary wire and mows the lawn efficiently with guide wires.
- Automatically recharges the battery and resumes mowing when the charging is completed.

Max work area
3,500m²
 120 hours of continuous operation
 Work area with a coverage rate of 98% or more when charging and operation are repeated

Charging time
40 min.
 Average charging time in continuous automatic operation

Continuous use
135 min.*

*The continuous run time is a rough indication of the mean run time according to EGMF-standard (500m², 15mm cutting, 60-hour continuous operation), and depends on the operation time setting, work area, cutting height, and lawn density/condition.

Washable with water

- The top cover can be removed to wash the entire machine. (not washable with high-pressure water)
- Reduces the burden of off-season maintenance.



Spiral cut

The mower automatically detects high/dense grass and moves slowly in a spiral pattern to gradually cut the grass with a minimum of uncut area.



Max climbing angle: 26°

Mows even on undulating lawn due to the high traveling performance on slopes.

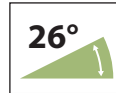

Determining the cutting height

If the lawn is high, user can let the mower automatically mow the lawn down to a desired height gradually in stages over several days by setting the starting height and desired height in the mower. (When using the Competitor H1's robotic mower for this operation, user has to reset the heights after each and every stage.)

Setting range of cutting height **20 - 60 mm**
 5 mm increments / 9 stages



Mowing start position setting

- Up to 5 start positions for mowing can be set.
- If the setting position is not at the station, the robotic mower travels along wires and starts mowing in a random mode.
- It is possible to control mowing frequency variation in areas where mowing is less frequent, such as at the end of narrow aisles.



Theft-deterrent

Setting a PIN code and the alarm function deter theft of the machine.



Robotic Mower



	RM350D
Max work area	3,500 m ²
Continuous use	135 min.
Charging time approx.	40 min
Cutting width	240 mm (9-1/2 ")
No load speed	2,300 min ⁻¹
Cutting height adjustment	Adjustment range: 20 - 60 mm (13/16 - 2-3/8 ")
Max climbing angle	26°
Dimensions (L x W x H)	700 x 560 x 270 mm (27-1/2 x 22 x 10-5/8 ")
Net weight	13.7 kg (30.2 lbs.)

	Battery	Battery slots	Class	Deck	Soft no load	Self-Propelled	BL MOTOR	Rear discharge	Side discharge		
LM004J	64V max	1	530 mm (21")	Steel	✓	✓	✓	✓	✓*		
LM003J			480 mm (18-7/8")		✓	✓	✓	✓	✓*		
LM002J			530 mm (21")	Plastics	✓	-	✓	✓	-		
LM001J			480 mm (18-7/8")		✓	-	✓	✓	-		
LM001C		-	530 mm (21")	Steel	✓	✓	✓	-	✓*		
LM002G	40V max	530 mm (21")	✓		✓	✓	✓	✓*			
LM001G		480 mm (18-7/8")	✓		✓	✓	✓	✓			
LM004G		1	430 mm (17")		-	-	-	-	-		
LM003G	380 mm (15")		-	-	-	-	-				
DLM533	18V x2	4	530 mm (21")	Aluminum	✓	✓	✓	✓	-		
DLM537				-	✓	✓	✓	✓	-		
DLM532				✓	✓	✓	-	✓	-		
DLM536				-	✓	✓	-	✓	✓		
DLM530				✓	-	✓	-	✓	✓		
DLM534				-	-	✓	-	✓	✓		
DLM538				2	530 mm (21")	Plastics	✓	-	-	✓	-
DLM539							✓	✓	-	✓	-
DLM480		✓	-				-	✓	-		
DLM481		✓	✓				-	✓	-		
DLM462		4	460 mm (18-1/18")	Steel	✓	✓	✓	-	-		
DLM465					-	✓	✓	-	-		
DLM460					✓	-	✓	-	-		
DLM463					-	-	✓	-	-		
DLM432		2	430 mm (17")	Plastics	✓	-	-	-	-		
DLM382					✓	-	-	-	-		
DLM330					1	330 mm (13")	✓	-	-	-	-

Cordless Lawn Mower

64V max



	LM004J	LM003J
Cutting width	534 mm (21")	480 mm (18-7/8")
Actual mowing area on a full battery charge	w/ BL64100, Manual push: 2,800 m ² w/ BL64100, Self-propelled: 3,800 m ²	w/ BL64100, Manual push: 2,700 m ² w/ BL64100, Self-propelled: 3,700 m ²
No load speed	Normal mode: 2,800 min ⁻¹ Soft no-load mode: 2,300 - 2,800 min ⁻¹ Noise reduction mode: 2,300 min ⁻¹	Normal mode: 3,200 min ⁻¹ Soft no-load mode: 2,500 - 3,200 min ⁻¹ Noise reduction mode: 2,500 min ⁻¹
Propelling speed	1.5 - 6.5 km/h	1.5 - 6.5 km/h
Grass catcher capacity	70 L (2,366 oz)	62 L (2,182 oz)
Cutting height adjustment	Adjustment range: 20 - 100 mm (13/16 - 3-15/16")	Adjustment range: 20 - 100 mm (13/16 - 3-15/16")
Dimensions (L x W x H)	During operation: 1,740 - 1,810 x 595 x 970 - 1,080 mm (68-1/2 - 71-1/4 x 23-1/2 x 38-1/4 - 42-1/2")	During operation: 1,670 - 1,745 x 550 x 965 - 1,075 mm (65-3/4 - 68-3/4 x 21-5/8 x 38 - 42-1/4")
Net weight	31.5 - 34.6 kg (69.5 - 76.3 lbs.)	30.9 - 33.8 kg (68.1 - 74.5 lbs.)

Cordless Lawn Mower

64V max



	LM002J	LM001J
Cutting width	534 mm (21")	480 mm (18-7/8")
Actual mowing area on a full battery charge	w/ BL6440: 1,600 m ²	w/ BL6440: 1,400 m ²
Continuous use (approx.) on a full battery charge	w/ BL6440: 39 min.	w/ BL6440: 34 min.
No load speed	Normal mode: 2,800 min ⁻¹ / Soft no-load mode: 2,300 - 2,800 min ⁻¹ Noise reduction mode: 2,300 min ⁻¹	Normal mode: 3,200 min ⁻¹ / Soft no-load mode: 2,500 - 3,200 min ⁻¹ Noise reduction mode: 2,500 min ⁻¹
Grass catcher capacity	70 L (2,367 oz)	62 L (2,096 oz)
Cutting height adjustment	Adjustment range: 20 - 100 mm (13/16 - 3-15/16")	Adjustment range: 20 - 100 mm (13/16 - 3-15/16")
Dimensions (L x W x H)	During operation: 1,710 - 1,800 x 585 x 950 - 1,090 mm (67-1/2 - 71 x 23 x 37-1/2 - 43")	During operation: 1,610 - 1,690 x 530 x 930 - 1,050 mm (63-1/2 - 66-1/2 x 20-7/8 x 36-5/8 - 41-1/4")
Net weight	25.7 - 28.6 kg (56.7 - 63.1 lbs.)	24.4 - 27.1 kg (53.8 - 59.7 lbs.)

Battery Powered Lawn Mower



	LM001C
Cutting width	534 mm (21")
Actual mowing area on a full battery charge	w/ PDC1200, Manual push: 6,900 m ² w/ PDC1200, Self-propelled: 5,100 m ²
No load speed	Normal mode: 2,800 min ⁻¹ / Soft no-load mode: 2,300 - 2,800 min ⁻¹ Noise reduction mode: 2,300 min ⁻¹
Continuous use	w/ PDC1200, 2-tooth blade, Self-propelled: 120 min. w/ PDC1200, 2-tooth blade, Manual push: 150 min.
Grass box capacity	70 L
Cutting height	20 - 100 mm (13/16 - 3-15/16")
Propelling speed	2.5 - 5.0 km/h
Dimensions (L x W x H)	1,630 - 1,715 x 590 x 990 - 1,095 mm (64 - 67-1/2 x 23-1/4 x 39 - 43")
Net weight	42.1 - 49.5 kg (92.8 - 109.1 lbs.)

Cordless Lawn Mower

40V max

XGT BL SOFT NOLOAD **XPT**



	LM002G	LM001G
Cutting width	534 mm (21")	480 mm (18-7/8")
Actual mowing area on a full battery charge	w/ BL4080F x2, Manual push: 3,400 m ² w/ BL4080F x2, Self-propelled: 2,500 m ²	w/ BL4080F x2, Manual push: 2,600 m ² w/ BL4080F x2, Self-propelled: 2,100 m ²
Continuous use (approx.) on a full battery charge	w/ BL4080F x2, Manual push: 76 min. w/ BL4080F x2, Self-propelled: 56 min.	w/ BL4080F x2, Manual push: 71 min. w/ BL4080F x2, Self-propelled: 58 min.
No load speed	Normal mode: 2,800 min ⁻¹ / Soft no-load mode: 2,300 - 2,800 min ⁻¹ / Noise reduction mode: 2,300 min ⁻¹	Normal mode: 3,200 min ⁻¹ / Soft no-load mode: 2,500 - 3,200 min ⁻¹ / Noise reduction mode: 2,500 min ⁻¹
Propelling speed	1.5 - 5.0 km/h	1.5 - 5.0 km/h
Grass catcher capacity	70 L (2,366 oz)	62 L (2,182 oz)
Cutting height adjustment	Adjustment range: 20 - 100 mm (13/16 - 3-15/16")	Adjustment range: 20 - 100 mm (13/16 - 3-15/16")
Dimensions (L x W x H)	During operation: 1,740 - 1,810 x 595 x 970 - 1,080 mm (68-1/2 - 71-1/4 x 23-1/2 x 38-1/4 - 42-1/2")	During operation: 1,670 - 1,745 x 550 x 965 - 1,075 mm (65-3/4 - 68-3/4 x 21-5/8 x 38 - 42-1/4")
Net weight	29.5 - 34.7 kg (65.0 - 76.5 lbs.)	28.0 - 33.0 kg (61.7 - 72.8 lbs.)

Cordless Lawn Mower

40V max

XGT XPT



	LM004G	LM003G
Cutting width	430 mm (17")	380 mm (15")
Actual mowing area on a full battery charge	w/ BL4080F: 830 m ²	w/ BL4080F: 780 m ²
Continuous use (approx.) on a full battery charge	w/ BL4080F: 53 min.	w/ BL4080F: 48 min.
No load speed	3,800 min ⁻¹	3,800 min ⁻¹
Grass catcher capacity	50 L (1,691 oz)	40 L (1,353 oz)
Cutting height adjustment	Adjustment range: 20 - 75 mm (13/16 - 2-15/16")	Adjustment range: 20 - 75 mm (13/16 - 2-15/16")
Dimensions (L x W x H)	During operation: 1,390 - 1,440 x 460 x 990 - 1,020 mm (54-3/4 - 56-3/4 x 18-1/8 x 39 - 40-1/4")	During operation: 1,370 - 1,420 x 450 x 990 - 1,020 mm (54 - 56 x 17-3/4 x 39 - 40-1/4")
Net weight	15.6 - 18.2 kg (34.4 - 40.1 lbs.)	14.9 - 17.3 kg (32.8 - 38.1 lbs.)

Cordless Lawn Mower

18V x2

LXT BL SOFT NOLOAD **XPT**



	DLM533	DLM537
Cutting width	534 mm (21")	534 mm (21")
Actual mowing area on a full battery charge	w/ BL1860B x4, Self-propelled: 1,700 m ²	w/ BL1860B x4, Manual push: 2,300 m ² w/ BL1860B x4, Self-propelled: 1,700 m ²
Continuous run time on full battery charge	w/ BL1860B x4, Self-propelled: 40 min.	w/ BL1860B x4, Manual push: 54 min. w/ BL1860B x4, Self-propelled: 40 min.
No load speed	Standard mode: 2,300, 2,800 min ⁻¹ / Low noise mode: 2,300 min ⁻¹	Standard mode: 2,800 min ⁻¹ / Low noise mode: 2,300 min ⁻¹
Propelling speed	2.5 - 5.0 km/h	2.5 - 5.0 km/h
Grass box capacity	70 L	70 L
Cutting height adjustment	Adjustment range: 20 - 100 mm (13/16 - 3-15/16")	Adjustment range: 20 - 100 mm (13/16 - 3-15/16")
Dimensions (L x W x H)	1,655 - 1,740 x 590 x 990 - 1,100 mm (65 - 68-1/2 x 23-1/4 x 39 - 43-1/4")	1,655 - 1,740 x 590 x 990 - 1,100 mm (65 - 68-1/2 x 23-1/4 x 39 - 43-1/4")
Net weight	42.8 - 46.7 kg (94.4 - 103 lbs.)	42.8 - 46.7 kg (94.4 - 103 lbs.)

Cordless Lawn Mower

18V x2

LXT BL SOFT NOLOAD **XPT**



	DLM532	DLM536
Cutting width	534 mm (21")	534 mm (21")
Actual mowing area on a full battery charge	w/ BL1860B x4, Manual push: 2,300 m ² w/ BL1860B x4, Self-propelled: 1,700 m ²	w/ BL1860B x4, Manual push: 2,300 m ² w/ BL1860B x4, Self-propelled: 1,700 m ²
Continuous run time on full battery charge	w/ BL1860B x4, Manual push: 54 min. w/ BL1860B x4, Self-propelled: 40 min.	w/ BL1860B x4, Manual push: 54 min. w/ BL1860B x4, Self-propelled: 40 min.
No load speed	2,300 - 2,800 min ⁻¹	Standard mode: 2,800 min ⁻¹ / Low noise mode: 2,300 min ⁻¹
Propelling speed	2.5 - 5.0 km/h	2.5 - 5.0 km/h
Grass box capacity	70 L	70 L
Cutting height adjustment	Adjustment range: 20 - 100 mm (13/16 - 3-15/16")	Adjustment range: 20 - 100 mm (13/16 - 3-15/16")
Dimensions (L x W x H)	1,630 - 1,715 x 590 x 990 - 1,095 mm (64 - 67-1/2 x 23-1/4 x 39 - 43")	1,630 - 1,715 x 590 x 990 - 1,095 mm (64 - 67-1/2 x 23-1/4 x 39 - 43")
Net weight	39.0 - 42.8 kg (86.0 - 94.4 lbs.)	39.0 - 42.8 kg (86.0 - 94.4 lbs.)

Cordless Lawn Mower

18V x2

LXT BL SOFT NOLOAD **XPT**



	DLM530	DLM534
Cutting width	534 mm (21")	534 mm (21")
Actual mowing area on a full battery charge	w/ BL1860B x4, Manual push: 2,300 m ²	w/ BL1860B x4, Manual push: 2,300 m ²
Continuous run time on full battery charge	w/ BL1860B x4, Manual push: 54 min.	w/ BL1860B x4, Manual push: 54 min.
No load speed	2,300 - 2,800 min ⁻¹	Standard mode: 2,800 min ⁻¹ / Low noise mode: 2,300 min ⁻¹
Grass box capacity	70 L	70 L
Cutting height adjustment	Adjustment range: 20 - 100 mm (13/16 - 3-15/16")	Adjustment range: 20 - 100 mm (13/16 - 3-15/16")
Dimensions (L x W x H)	1,630 - 1,715 x 590 x 990 - 1,095 mm (64 - 67-1/2 x 23-1/4 x 39 - 43")	1,630 - 1,715 x 590 x 990 - 1,095 mm (64 - 67-1/2 x 23-1/4 x 39 - 43")
Net weight	35.5 - 39.3 kg (78.3 - 86.6 lbs.)	35.5 - 39.3 kg (78.3 - 86.6 lbs.)

Cordless Lawn Mower

18V x2

DLM539: Self-Propelled

LXT XPT



	DLM539	DLM538
Cutting width	534 mm (21")	534 mm (21")
Actual mowing area on a full battery charge	w/ BL1860B x2, Manual push: 800 m ² w/ BL1860B x2, Self-propelled: 700 m ²	w/ BL1860B x2, Manual push: 800 m ²
Continuous run time on full battery charge	w/ BL1860B x2, Manual push: 25 min. w/ BL1860B x2, Self-propelled: 22 min.	w/ BL1860B x2, Manual push: 25 min.
No load speed	3,000 min ⁻¹	3,000 min ⁻¹
Propelling speed	2.5 - 5.0 km/h	-
Grass box	Capacity: 70 L (2,367 oz)	Capacity: 70 L (2,367 oz)
Cutting height adjustment	Adjustment range: 20 - 100 mm (13/16 - 3-15/16")	Adjustment range: 20 - 100 mm (13/16 - 3-15/16")
Dimensions (L x W x H)	During operation: 1,810 - 1,870 x 530 x 930 - 1,040 mm (71-1/4 - 73-1/2 x 23 x 36-1/4 - 41")	During operation: 1,810 - 1,870 x 530 x 930 - 1,040 mm (71-1/4 - 73-1/2 x 22-3/4 x 36-1/4 - 41")
Net weight	27.9 - 30.4 kg (61.5 - 67.0 lbs.)	25.5 - 28.0 kg (56.2 - 61.7 lbs.)

Cordless Lawn Mower

18V x2

DLM481: Self-Propelled

LXT XPT



	DLM481	DLM480
Cutting width	480 mm (18-7/8")	480 mm (18-7/8")
Actual mowing area on a full battery charge	w/ BL1860B x2, Manual push: 800 m ² w/ BL1860B x2, Self-propelled: 650 m ²	w/ BL1860B x2, Manual push: 800 m ²
Continuous run time on full battery charge	w/ BL1860B x2, Manual push: 28 min. w/ BL1860B x2, Self-propelled: 23 min.	w/ BL1860B x2, Manual push: 28 min.
No load speed	3,100 min ⁻¹	3,100 min ⁻¹
Propelling speed	2.5 - 5.0 km/h	-
Grass box	Capacity: 62 L (2,096 oz)	Capacity: 62 L (2,096 oz)
Cutting height adjustment	Adjustment range: 20 - 100 mm (13/16 - 3-15/16")	Adjustment range: 20 - 100 mm (13/16 - 3-15/16")
Dimensions (L x W x H)	During operation: 1,690 - 1,740 x 530 x 930 - 1,060 mm (66-1/2 - 68-1/2 x 20-7/8 x 36-5/8 - 41-3/4")	During operation: 1,690 - 1,740 x 530 x 930 - 1,060 mm (66-1/2 - 68-1/2 x 20-7/8 x 36-5/8 - 41-3/4")
Net weight	27.1 - 29.3 kg (59.7 - 64.6 lbs.)	24.5 - 26.8 kg (54.0 - 59.1 lbs.)

Lawn care/Grass care

Cordless Lawn Mower

18V x2

▼ DLM462

LXI BL SOFT NOLOAD XPT



	DLM462	DLM465
Cutting width	460 mm (18-1/8")	460 mm (18-1/8")
Actual mowing area on a full battery charge	w/ BL1860B x4, Manual push: 1,900 m ²	w/ BL1860B x4, Manual push: 1,900 m ²
Continuous run time on full battery charge	w/ BL1860B x4, Self-propelled: 1,400 m ²	w/ BL1860B x4, Self-propelled: 1,400 m ²
No load speed	2,500 - 3,300 min ⁻¹	w/ BL1860B x4, Manual push: 51 min.
Propelling speed	w/ BL1860B x4, Self-propelled: 40 min.	w/ BL1860B x4, Self-propelled: 40 min.
Grass box capacity	2,500 - 3,300 min ⁻¹	Standard mode: 3,300 min ⁻¹ / Low noise mode: 2,500 min ⁻¹
Cutting height adjustment	2.5 - 5.0 km/h	2.5 - 5.0 km/h
Dimensions (L x W x H)	60 L	60 L
Net weight	Adjustment range: 20 - 100 mm (13/16 - 3-15/16")	Adjustment range: 20 - 100 mm (13/16 - 3-15/16")
	1,610-1,690 x 535 x 980-1,095 mm (63-1/2"-66-1/2" x 21 x 38-1/2"-43")	1,690 x 535 x 980 - 1,095 mm (63-1/2" - 66-1/2" x 21 x 38-1/2" - 43")
	35.3 - 39.0 kg (77.8 - 86.0 lbs.)	35.3 - 39.0 kg (77.8 - 86.0 lbs.)

Cordless Lawn Mower

18V x2

▼ DLM460

LXI BL SOFT NOLOAD XPT



	DLM460	DLM463
Cutting width	460 mm (18-1/8")	460 mm (18-1/8")
Actual mowing area on a full battery charge	w/ BL1860B x2: 800 m ²	w/ BL1860B x2: 800 m ²
Continuous run time on full battery charge	w/ BL1860B / BL1850B / BL1840B / BL1830B / BL1820B / BL1815N: 21 / 18 / 14 / 10 / 8 / 6 min.	w/ BL1860B / BL1850B / BL1840B / BL1830B / BL1820B / BL1815N: 21 / 18 / 14 / 10 / 8 / 6 min.
No load speed	2,500 - 3,300 min ⁻¹	Standard mode: 3,300 min ⁻¹ / Low noise mode: 2,500 min ⁻¹
Grass box capacity	60 L	60 L
Cutting height adjustment	Adjustment range: 20 - 75 mm (13/16 - 2-5/16")	Adjustment range: 20 - 75 mm (13/16 - 2-5/16")
Dimensions (L x W x H)	During operation: 1,319 - 1,518 x 532 x 879 - 1,138 mm (52 - 59-3/4" x 21 x 34-1/2" - 44-3/4")	During operation: 1,319 - 1,518 x 532 x 879 - 1,138 mm (52 - 59-3/4" x 21 x 34-1/2" - 44-3/4")
Net weight	25.3 - 27.6 kg (55.8 - 60.8 lbs.)	25.3 - 27.6 kg (55.8 - 60.8 lbs.)

Cordless Lawn Mower

18V x2

LXI XPT



	DLM432	DLM382
Cutting width	430 mm (17")	380 mm (15")
Actual mowing area on a full battery charge	w/ BL1860B x2: 575 m ²	w/ BL1860B x2: 560 m ²
Continuous run time on full battery charge	w/ 1860B x2: 36 min.	w/ 1860B x2: 35 min.
No load speed	3,600 min ⁻¹	3,700 min ⁻¹
Grass catcher capacity	40 L (1,353 oz)	40 L (1,353 oz)
Cutting height adjustment	Adjustment range: 20 - 75 mm (13/16 - 2-15/16")	Adjustment range: 20 - 75 mm (13/16 - 2-15/16")
Dimensions (L x W x H)	During operation: 1,435 - 1,490 x 460 x 1,005 - 1,045 mm (56-1/2" - 58-3/4" x 18-1/8" x 39-1/2" - 41-1/4")	During operation: 1,380 - 1,410 x 450 x 985 - 1,005 mm (54-1/4" - 55-1/2" x 17-3/4" x 38-3/4" - 39-1/2")
Net weight	16.8 - 17.5 kg (37.0 - 38.6 lbs.)	16.2 - 16.9 kg (35.7 - 37.3 lbs.)

Cordless Lawn Mower

18V

LXI XPT



	DLM330
Cutting width	330 mm (13")
Actual mowing area on a full battery charge	w/ BL1840B: 270 m ²
Continuous run time on full battery charge	w/ BL1840B: 14 min.
No load speed	4,300 min ⁻¹
Grass box capacity	Capacity: 30 L (1,014 oz)
Cutting height adjustment	Adjustment range: 20 - 75 mm (13/16 - 2-15/16")
Dimensions (L x W x H)	During operation: 1,285 - 1,350 x 375 x 935 - 975 mm (50-1/2" - 53" x 14-3/4" x 36-3/4" - 38-3/8")
Net weight	11.6 - 12.5 kg (25.6 - 27.6 lbs.)

Electric Lawn Mower

Self-Propelled



	ELM4621
Continuous rating Input	1,800W
Cutting width	460 mm (18-1/8")
Recommended mowing area up to	1,000 m ²
No load speed	2,950 min ⁻¹
Propelling speed	3.6 km/h
Grass box capacity	60 L
Cutting height	20 - 75 mm (13/16 - 2-15/16")
Dimensions (L x W x H)	During operation: 1,790 x 570 x 950 - 1,165 mm (70-1/2" x 22-1/2" x 37-3/8" - 45-7/8")
Net weight	When stored (w/o Grass box): 590 x 570 x 1,220 mm (23-1/4" x 22-1/2" x 48")
	30.5 - 32.2 kg (67.2 - 71.0 lbs.)

Electric Lawn Mower



	ELM4620
Continuous rating Input	1,800W
Cutting width	460 mm (18-1/8")
Recommended mowing area up to	800 m ²
No load speed	2,950 min ⁻¹
Grass box capacity	60 L
Cutting height	20 - 75 mm (13/16 - 2-15/16")
Dimensions (L x W x H)	During operation: 1,700 x 570 x 950 - 1,165 mm (67 x 22-1/2" x 37-3/8" - 45-7/8")
Net weight	When stored (w/o Grass box): 515 x 570 x 1,125 mm (20-1/4" x 22-1/2" x 44-1/4")
	27.7 - 29.2 kg (61.1 - 64.4 lbs.)

Electric Lawn Mower

3 in 1 (Lawnmowing / Grass collecting / Mulching)



	ELM4121
Continuous rating Input	1,600W
Cutting width	410 mm (16-1/8")
Recommended mowing area up to	600 m ²
No load speed	3,400 min ⁻¹
Grass box capacity	50 L
Cutting height	20 - 75 mm (13/16 - 2-15/16")
Dimensions (L x W x H)	During operation: 1,465 x 530 x 905 - 1,135 mm (57-3/4" x 20-7/8" x 35-5/8" - 44-3/4")
Net weight	When stored (w/o Grass box): 390 x 530 x 1,070 mm (15-3/8" x 20-7/8" x 42")
	17.5 - 19.1 kg (38.6 - 42.1 lbs.)

Lawn care/Grass care

Electric Lawn Mower

2 in 1 (Lawnmowing / Grass collecting)



ELM4120	
Continuous rating Input	1,600W
Cutting width	410 mm (16-1/8")
Recommended mowing area up to	600 m ²
No load speed	3,400 min ⁻¹
Grass box capacity	45 L
Cutting height	20 - 75 mm (13/16 - 2-15/16")
Dimensions (L x W x H)	During operation: 1,470 x 460 x 955 - 1,230 mm (57-7/8 x 18-1/8 x 37-5/8 - 48-3/8") When stored (w/o Grass box): 395 x 460 x 1,220 mm (15-1/2 x 18-1/8 x 48")
Net weight	14.5 kg (32.0 lbs.)

Electric Lawn Mower



ELM3720		ELM3320	
Continuous rating Input	1,400W	1,200W	
Cutting width	370 mm (14-1/2")	330 mm (13")	
Recommended mowing area up to	500 m ²	400 m ²	
No load speed	3,400 min ⁻¹	3,400 min ⁻¹	
Grass box capacity	40 L	30 L	
Cutting height	20 - 55 mm (13/16 - 2-3/16")	20 - 55 mm (13/16 - 2-3/16")	
Dimensions (L x W x H)	During operation: 1,330 x 415 x 890 - 1,120 mm (52-3/8 x 16-3/8 x 35 - 44") When stored (w/o Grass box): 335 x 415 x 1,090 mm (13-1/4 x 16-3/8 x 43")	During operation: 1,230 x 380 x 870 - 1,110 mm (48-1/2 x 15 x 34-1/4 - 43-3/4") When stored (w/o Grass box): 350 x 380 x 1,090 mm (13-3/4 x 15 x 43")	
Net weight	11.6 kg (25.6 lbs.)	10.2 kg (22.5 lbs.)	

Cordless Scarifier

40V max

XGT BL XPT



UV001G	
Cutting width	380 mm (15")
Working depth (Scarifier)	-12 mm (-15/32") to 5 mm (+3/16")
Actual working area on a full battery charge	500 / 510 m ²
(Battery)	BL4080F x2
(Mode)	Scarifying blade / Dethatching blade
Continuous use (Battery)	38 / 41 min.
(Battery)	BL4080F x2
(Mode)	Scarifying blade / Dethatching blade
No load speed	3,200 min ⁻¹
Foldable handle	Stage: 2
Dimensions (L x W x H)	1,020-1,240 x 680 x 915-1,155 mm (40-1/4-48-3/4 x 26-3/4 x 36-45-1/2")
Net weight	18.7-23.8 kg (41.2-52.5 lbs.)

Cordless Scarifier

18V

new LXT BL XPT



DUV320	
Cutting width	320 mm (12-5/8")
Working depth	Adjustment range: -8 / -4 / 0 / 4 mm (-5/16 / -5/32 / 0 / 5/32")
Actual working area on a full battery charge	128 / 122 m ²
(Battery)	BL1860B
(Mode)	Scarifying blade / Dethatching blade
Continuous use (Battery)	13 / 13 min.
(Battery)	BL1860B
(Mode)	Scarifying blade / Dethatching blade
No load speed	3,300 min ⁻¹
Foldable handle	Stage: 3
Dimensions (L x W x H)	1,035 x 565 x 995 mm (40-3/4 x 22-1/4 x 39-1/4")
Net weight	10.1-10.4 kg (22.3-22.9 lbs.)

Electric Scarifier



UV3600

UV3200

UV3600		UV3200	
Continuous rating Input	1,800W	1,300W	
Cutting width	360 mm (14-1/5")	320 mm (12-3/5")	
Working depth (Scarifier)	-10 / -5 / 0 / 5 mm (-3/8 / -3/16 / 0 / +3/16")	-10 / -5 / 0 / 5 / 10 mm (-3/8 / -3/16 / 0 / +3/16 / +3/8")	
No load speed	3,500 min ⁻¹	3,000 min ⁻¹	
Grass catcher capacity	40 L (1,353 oz)	30 L	
Dimensions (L x W x H)	880 x 590 x 970 mm (34-3/4 x 23-1/4 x 38-1/4")	730 x 580 x 1,050 mm (28-3/4 x 22-3/4 x 41-1/4")	
Net weight	15.3 kg (33.7 lbs.)	12 kg (26.5 lbs.)	

Electric Shredder



UD2500	
Continuous rating Input	2,500W
Max branch	45 mm (1-4/5")
Cutting	40 min ⁻¹
Tank	67 L
Dimensions (L x W x H)	650 x 500 x 880 mm (25-1/2 x 19-3/4 x 34-3/4")
Net weight	27.6 kg (60.8 lbs.)



Lawn care/Grass care

	Battery	Max Output	Handle	Nylon	Plastic	Metal	BL MOTOR	ADT	AFT	
UR101C		1.0kW	Offset bike	430mm	255 / 305mm	255mm	✓	✓	✓	
UR201C			Loop							
UR202C			430mm	255 / 305mm	-					
UR012G	40V max x2	2.0kW	Offset bike	480mm	305mm	255 / 305mm	✓	✓	✓	
UR013G	40V max	1.5kW	Offset bike	450mm	305mm	255mm	✓	-	✓	
UR014G			Loop	450mm	-	-				
UR006G		1.0kW	Offset bike	430mm	255 / 305mm	255mm	✓	✓	✓	
UR007G			Loop							
UR008G			430mm	255 / 305mm	-					
UR002G		0.55kW	Offset bike	350mm	255mm	230mm	✓	✓	✓	
UR003G			Loop							
UR016G			0.53kW	Offset bike	330mm	255mm	230mm	✓	✓	✓
UR017G				Loop						
DUR369A			18V x2	1.0kW	Offset bike	430mm	255 / 305mm	230 / 255mm	✓	✓
DUR369L	Loop									
DUR369N	430mm	255 / 305mm		-						
DUR368A	0.55kW	Offset bike	350mm	255mm	230 / 255mm	✓	✓	✓		
DUR368L		Loop								
DUR190U	18V	240W	Offset bike	300mm	255mm	230mm	✓	✓	✓	
DUR191U			Loop							
DUR190L			Loop							
DUR191L			Loop							
DUR194	18V	230W	Offset bike	280mm	230mm	200mm	-	-	-	
DUR189		240W	Loop	300mm	255mm	-	✓	✓	-	
DUR192L		460W	Loop	300mm	-	-	✓	-	-	
DUR193		280W	Loop	260mm	-	-	-	-	-	
DUR181		230W	Loop	260mm	-	-	-	-	-	
UR100D		12V max	130W	Loop	260mm	230mm	-	-	-	
UR180D	18V	230W	Loop	260mm	-	-	-	-		
UR140D	14.4V	160W	Loop	260mm	-	-	-	-		
UR3502	AC	-	Loop	350mm	-	230mm	-	-	-	
UR3501		-	Loop	350mm	-	-				
UR3500		-	Loop	350mm	-	-				
UR2300		-	Loop	350mm	-	230mm				
UR3000		-	Loop	300mm	-	-				
UR3000		-	Loop	300mm	-	-				

Battery Powered Grass Trimmer
UR101C



No load speed Metal blade (3 / 2 / 1):
0 - 7,000 / 0 - 5,500 / 0 - 4,600 min⁻¹
Nylon cutting head (3 / 2 / 1):
0 - 5,500 / 0 - 5,000 / 0 - 4,600 min⁻¹
Plastic blade (305 mm) (3 / 2 / 1):
0 - 7,000 / 0 - 5,500 / 0 - 4,600 min⁻¹

Cutting width Metal blade: 255 mm (10")
Nylon cutting head: 430 mm (17")
Plastic blade: 305 mm (12")

Spindle size M10 x 1.25 LH
Dimensions 1,760 x 628 x 550 mm
(L x W x H) (69-1/4 x 24-3/4 x 21-5/8")
Net weight 5.2 kg (11.5 lbs.)



Battery Powered Grass Trimmer
UR201C



No load speed Metal blade (3 / 2 / 1):
0 - 7,000 / 0 - 5,500 / 0 - 4,600 min⁻¹
Nylon cutting head (3 / 2 / 1):
0 - 5,500 / 0 - 5,000 / 0 - 4,600 min⁻¹
Plastic blade (305 mm) (3 / 2 / 1):
0 - 7,000 / 0 - 5,500 / 0 - 4,600 min⁻¹

Cutting width Metal blade: 255 mm (10")
Nylon cutting head: 430 mm (17")
Plastic blade: 305 mm (12")

Spindle size M10 x 1.25 LH
Dimensions 1,795 x 400 x 269 mm
(L x W x H) (70-1/2 x 15-3/4 x 10-5/8")
Net weight 4.7 kg (10.4 lbs.)



Battery Powered Grass Trimmer
UR202C



No load speed Nylon cutting head (3 / 2 / 1):
0 - 5,000 / 0 - 4,600 / 0 - 4,000 min⁻¹

Cutting width Nylon cutting head: 430 mm (17")
Plastic blade: 305 mm (12")

Spindle size M10 x 1.25 LH
Dimensions 1,783 x 226 x 300 mm
(L x W x H) (70-1/4 x 8-15/16 x 11-7/8")
Net weight 4.4 kg (9.7 lbs.)



Cordless Grass Trimmer
UR012G



No load speed Metal blade (3 / 2 / 1):
0 - 6,800 / 0 - 5,000 / 0 - 3,500 min⁻¹
Nylon cutting head (3 / 2 / 1):
0 - 5,000 / 0 - 4,200 / 0 - 3,500 min⁻¹
Plastic blade (305 mm) (3 / 2 / 1):
0 - 6,800 / 0 - 5,000 / 0 - 3,500 min⁻¹

Cutting width Metal blade: 305 mm (12")
Chisel blade: 225 mm (8-7/8")
Nylon cutting head: 480 mm (18-7/8")
Plastic blade: 305 mm (12")

Spindle size M10 x 1.25 LH
Dimensions w/ Nylon cutting head, w/ BL4050F:
(L x W x H) 1,829 x 680 x 590 mm (72 x 26-3/4 x 23-1/4")
Net weight 8.0 - 9.3 kg (17.6 - 20.5 lbs.)



Cordless Grass Trimmer
UR013G



No load speed w/ Metal blade/ Plastic blade: 3,500 - 6,700 min⁻¹
w/ Nylon cutting head: 3,500 - 6,700 min⁻¹

Cutting width Metal blade: 255 mm (10")
Chisel blade: 225 mm (8-7/8")
Nylon cutting head: 450 mm (17-3/4")
Plastic blade: 305 mm (12")

Spindle size M10 x 1.25 LH
Continuous use w/ Metal blade, w/o load, w/ BL4050F,
(approx.) on a full High / Low: 86 / 267 min.
battery charge

Dimensions w/ Metal blade, w/ BL4080F:
(L x W x H) 1,966 x 690 x 546 mm
(77-1/2 x 27-1/4 x 21-1/2")
Net weight 5.9 - 7.2 kg (13.0 - 15.9 lbs.)



Cordless Grass Trimmer
UR014G



No load speed w/ Nylon cutting head:
4,000 - 5,700 min⁻¹

Cutting width Nylon cutting head: 450 mm (17-3/4")

Spindle size M10 x 1.25 LH
Dimensions w/ Nylon cutting head, w/ BL4080F:
(L x W x H) 1,958 x 330 x 304 mm (77 x 13 x 12")
Net weight 5.5 - 6.7 kg (12.1 - 14.8 lbs.)



Cordless Grass Trimmer
UR006G



No load speed Metal blade (3 / 2 / 1):
0 - 7,000 / 0 - 5,500 / 0 - 4,600 min⁻¹
Nylon cutting head (3 / 2 / 1):
0 - 5,500 / 0 - 5,000 / 0 - 4,600 min⁻¹
Plastic blade (305 mm) (3 / 2 / 1):
0 - 7,000 / 0 - 5,500 / 0 - 4,600 min⁻¹

Cutting width Metal blade: 255 mm (10")
Nylon cutting head: 430 mm (17")
Plastic blade: 305 mm (12")

Spindle size M10 x 1.25 LH
Dimensions w/ 255 mm 2-tooth metal blade,
(L x W x H) w/ BL4050F: 1,909 x 681 x 540 mm
(75 x 26-3/4 x 21-1/4")
Net weight 5.7 - 6.3 kg (12.6 - 13.9 lbs.)



Cordless Grass Trimmer
UR007G



No load speed Metal blade (3 / 2 / 1):
0 - 7,000 / 0 - 5,500 / 0 - 4,600 min⁻¹
Nylon cutting head (3 / 2 / 1):
0 - 5,500 / 0 - 5,000 / 0 - 4,600 min⁻¹
Plastic blade (305 mm) (3 / 2 / 1):
0 - 7,000 / 0 - 5,500 / 0 - 4,600 min⁻¹

Cutting width Metal blade: 255 mm (10")
Nylon cutting head: 430 mm (17")
Plastic blade: 305 mm (12")

Spindle size M10 x 1.25 LH
Dimensions w/ 255 mm 2-tooth metal blade,
(L x W x H) w/ BL4050F: 1,909 x 396 x 266 mm
(75 x 15-5/8 x 10-1/2")
Net weight 5.3 - 5.9 kg (11.7 - 13.0 lbs.)



Cordless Grass Trimmer
UR008G



No load speed Nylon cutting head (3 / 2 / 1):
0 - 5,000 / 0 - 4,600 / 0 - 4,000 min⁻¹
Plastic blade (305 mm) (3 / 2 / 1):
0 - 6,000 / 0 - 4,600 / 0 - 4,000 min⁻¹

Cutting width Nylon cutting head: 430 mm (17")
Plastic blade: 305 mm (12")

Spindle size M10 x 1.25 LH
Dimensions w/ Nylon cutting head 95M-10L,
(L x W x H) w/ BL4050F: 1,862 x 224 x 300 mm
(73-1/4 x 8-7/8 x 11-3/4")
Net weight 5.0 - 5.7 kg (11.0 - 12.6 lbs.)



Cordless Grass Trimmer
UR002G



No load speed High / Med. / Low:
0 - 6,500 / 5,300 / 3,500 min⁻¹

Cutting width Metal blade: 230 mm (9")
Nylon cutting head: 350 mm (13-3/4")
Plastic blade: 255 mm (10")

Spindle size M10 x 1.25 LH
Run time, w/ Metal blade, w/o load
w/ BL4050F High / Med. / Low:
153 / 227 / 505 min

Dimensions w/ 230 mm 4-tooth metal blade,
(L x W x H) w/ BL4050F: 1,829 x 630 x 500 mm
(72 x 24-3/4 x 19-3/4")
Net weight 4.6 - 5.3 kg (10.1 - 11.6 lbs.)



Lawn care/Grass care

Cordless Grass Trimmer
UR003G

40V max



No load speed	High / Med. / Low: 0 - 6,500 / 5,300 / 3,500 min ⁻¹
Cutting width	Metal blade: 230 mm (9") Nylon cutting head: 350 mm (13-3/4") Plastic blade: 255 mm (10")
Spindle size	M10 x 1.25 LH
Run time, w/ Metal blade, 153 / 227 / 505 min w/o load	w/ BL4050F High / Med. / Low: w/ Metal blade, 153 / 227 / 505 min
Dimensions (L x W x H)	w/ 230 mm 4-tooth metal blade, w/ BL4050F: 1,829 x 355 x 230 mm (72 x 14 x 9")
Net weight	4.1 - 4.7 kg (9.0 - 10.4 lbs.)

XGT MOTOR BL ADT AFT XPT

Cordless Grass Trimmer
UR017G

40V max



No load speed	High / Med. / Low: 6,500 / 5,300 / 3,500 min ⁻¹
Cutting width	Metal blade: 230 mm (9") Nylon cutting head: 330 mm (13") Plastic blade: 255 mm (10")
Spindle size	M10 x 1.25 LH
Dimensions (L x W x H)	w/ Plastic blade, w/ BL4040: 1,890 x 362 x 265 mm (74-1/2 x 14-1/4 x 10-3/8")
Net weight	4.2 - 4.8 kg (9.3 - 10.6 lbs.)

XGT MOTOR BL ADT AFT XPT

Cordless Grass Trimmer
UR016G

40V max



No load speed	High / Med. / Low: 6,500 / 5,300 / 3,500 min ⁻¹
Cutting width	Metal blade: 230 mm (9") Nylon cutting head: 330 mm (13") Plastic blade: 255 mm (10")
Spindle size	M10 x 1.25 LH
Dimensions (L x W x H)	w/ Plastic blade, w/ BL4040: 1,890 x 625 x 537 mm (74-1/2 x 24-5/8 x 21-1/8")
Net weight	4.7 - 5.3 kg (10.4 - 11.7 lbs.)

XGT MOTOR BL ADT AFT XPT

Cordless Grass Trimmer
DUR369A

18V x2



No load speed	Metal blade (3 / 2 / 1): 0 - 7,000 / 0 - 5,500 / 0 - 4,600 min ⁻¹ Nylon cutting head (3 / 2 / 1): 0 - 5,500 / 0 - 5,000 / 0 - 4,600 min ⁻¹ Plastic blade (305 mm) (3 / 2 / 1): 0 - 7,000 / 0 - 5,500 / 0 - 4,600 min ⁻¹
Cutting width	Metal blade: 255 mm (10") Nylon cutting head: 430 mm (17") Plastic blade: 305 mm (12")
Spindle size	M10 x 1.25 LH
Dimensions (L x W x H)	1,846 x 628 x 530 mm (72-1/2 x 24-3/4 x 20-7/8")
Net weight	5.9 - 6.5 kg (13.0 - 14.3 lbs.)

LXI MOTOR BL ADT AFT XPT

Cordless Grass Trimmer
DUR369L

18V x2



No load speed	Metal blade (3 / 2 / 1): 0 - 7,000 / 0 - 5,500 / 0 - 4,600 min ⁻¹ Nylon cutting head (3 / 2 / 1): 0 - 5,500 / 0 - 5,000 / 0 - 4,600 min ⁻¹ Plastic blade (305 mm) (3 / 2 / 1): 0 - 7,000 / 0 - 5,500 / 0 - 4,600 min ⁻¹
Cutting width	Metal blade: 255 mm (10") Nylon cutting head: 430 mm (17") Plastic blade: 305 mm (12")
Spindle size	M10 x 1.25 LH
Dimensions (L x W x H)	1,846 x 400 x 269 mm (72-1/2 x 15-3/4 x 10-5/8")
Net weight	5.7 - 6.3 kg (12.6 - 13.9 lbs.)

LXI MOTOR BL ADT AFT XPT

Cordless Grass Trimmer
DUR369N

18V x2



No load speed	Nylon cutting head (3 / 2 / 1): 0 - 6,000 / 0 - 4,600 / 0 - 4,000 min ⁻¹
Cutting width	Nylon cutting head: 430 mm (17") Plastic blade: 305 mm (12")
Spindle size	M10 x 1.25 LH
Dimensions (L x W x H)	1,834 x 226 x 301 mm (72-1/2 x 8-15/16 x 11-7/8")
Net weight	5.5 - 6.1 kg (12.1 - 13.5 lbs.)

LXI MOTOR BL ADT AFT XPT

Cordless Grass Trimmer
DUR368A

18V x2



No load speed	High / Med. / Low: 6,500 / 5,300 / 3,500 min ⁻¹
Cutting width	Metal blade: 230 mm (9") Nylon cutting head: 350 mm (13-3/4") Plastic blade: 255 mm (10")
Spindle size	M10 x 1.25 LH
Run time, w/ Metal blade, 184 / 273 / 606 min w/o load	w/ BL1860B High / Med. / Low: w/ Metal blade, 184 / 273 / 606 min
Dimensions (L x W x H)	1,758 x 615 x 442 mm (69-1/4 x 24-1/4 x 17-3/8")
Net weight	4.1 - 4.7 kg (9.0 - 10.5 lbs.)

LXI MOTOR BL ADT AFT XPT

Cordless Grass Trimmer
DUR368L

18V x2



No load speed	High / Med. / Low: 6,500 / 5,300 / 3,500 min ⁻¹
Cutting width	Metal blade: 230 mm (9") Nylon cutting head: 350 mm (13-3/4") Plastic blade: 255 mm (10")
Spindle size	M10 x 1.25 LH
Run time, w/ Metal blade, 184 / 273 / 606 min w/o load	w/ BL1860B High / Med. / Low: w/ Metal blade, 184 / 273 / 606 min
Dimensions (L x W x H)	1,758 x 362 x 231 mm (69-1/4 x 14-1/4 x 9-1/8")
Net weight	3.9 - 4.5 kg (8.6 - 10.0 lbs.)

LXI MOTOR BL ADT AFT XPT

Cordless Grass Trimmer
DUR190U

18V



No load speed	3,500 - 6,000 min ⁻¹
Cutting width	Metal blade: 230 mm (9") Nylon cutting head: 300 mm (11-3/4") Plastic blade: 255 mm (10")
Spindle size	M10 x 1.25 LH
Dimensions (L x W x H)	1,836 x 610 x 473 mm (72-1/4 x 24 x 18-5/8")
Net weight	3.1 - 3.4 kg (6.8 - 7.5 lbs.)

LXI MOTOR BL ADT AFT XPT

Cordless Grass Trimmer
DUR190L

18V



No load speed	3,500 - 6,000 min ⁻¹
Cutting width	Metal blade: 230 mm (9") Nylon cutting head: 300 mm (11-3/4") Plastic blade: 255 mm (10")
Spindle size	M10 x 1.25 LH
Dimensions (L x W x H)	1,836 x 348 x 236 mm (72-1/4 x 13-3/4 x 9-1/4")
Net weight	2.9 - 3.2 kg (6.4 - 7.1 lbs.)

LXI MOTOR BL ADT AFT XPT



Lawn care/Grass care

Cordless Grass Trimmer DUR191U

18V



No load speed 3,500 - 6,000 min⁻¹
 Cutting width Metal blade: 230 mm (9")
 Nylon cutting head: 300 mm (11-3/4")
 Plastic blade: 255 mm (10")
 Spindle size M10 x 1.25 LH
 Dimensions 1,836 x 610 x 473 mm
 (L x W x H) (72-1/4 x 24 x 18-5/8")
 Net weight 3.4 - 3.7 kg (7.5 - 8.2 lbs.)

LXI MOTOR BL ADT AFT XPT



Cordless Grass Trimmer DUR191L

18V



No load speed 3,500 - 6,000 min⁻¹
 Cutting width Metal blade: 230 mm (9")
 Nylon cutting head: 300 mm (11-3/4")
 Plastic blade: 255 mm (10")
 Spindle size M10 x 1.25 LH
 Dimensions 1,836 x 345 x 236 mm
 (L x W x H) (72-1/4 x 13-5/8 x 9-1/4")
 Net weight 3.2 - 3.5 kg (7.1 - 7.7 lbs.)

LXI MOTOR BL ADT AFT XPT



Cordless Grass Trimmer DUR194

18V



No load speed High / Low: 6,000 / 4,500 min⁻¹
 Cutting width Metal blade: 200 mm (7-7/8")
 Nylon cutting head: 280 mm (11")
 Plastic blade: 230 mm (9")
 Spindle size M10 x 1.25 LH
 Dimensions w/ 200 mm 8-tooth metal blade,
 (L x W x H) w/ BL1830B / BL1840B / BL1850B /
 BL1860B: 1,630 x 288 x 236 mm
 (64 x 11-3/8 x 9-1/4")
 Net weight 2.6 - 2.9 kg (5.7 - 6.4 lbs.)

LXI XPT



Cordless Grass Trimmer DUR192L

18V



No load speed High / Low: 0 - 6,000 / 0 - 4,500 min⁻¹
 Cutting width Nylon cutting head: 300 mm (11-3/4")
 Spindle size M10 x 1.25 LH
 Max run time High / Low, w/ 300 mm (11-3/4") Nylon
 Cutting Head, w/o Load, w/ BL1850B:
 46 / 97 min.
 Dimensions w/ Nylon cutting head, BL1830B / BL1840B /
 (L x W x H) BL1850B / BL1860B: 1,705 x 186 x 246 mm
 (67 x 7-3/8 x 9-11/16")
 Net weight 2.7 - 3.0 kg (6.0 - 6.6 lbs.)

LXI MOTOR BL XPT



Cordless Grass Trimmer DUR189

18V



No load speed High / Med. / Low / ADT Mode:
 6,000 / 5,000 / 4,000 / 4,000 - 6,000 min⁻¹
 Cutting width Trimmer head: 300 mm (11-3/4")
 Plastic blade: 255 mm (10")
 Spindle size M8 x 1.25 RH
 Max run time Nylon cutting head, BL1860B: 168 min.
 Plastic blade, BL1860B: 219 min.
 Dimensions 1,518 - 1,618 x 258 x 396 mm
 (L x W x H) (59-3/4 - 63-3/4 x 10-1/8 x 15-5/8")
 Net weight 3 - 3.3 kg (6.6 - 7.3 lbs.)

LXI MOTOR BL ADT XPT



Cordless Grass Trimmer DUR193

18V



No load speed 7,800 min⁻¹
 Cutting width Nylon cutting head: 260 mm (10-1/4")
 Dimensions w/ Nylon cutting head, BL1830B /
 (L x W x H) BL1840B / BL1850B / BL1860B:
 1,248 - 1,436 x 265 x 358 mm
 (49-1/4 - 56-1/2 x 10-3/8 x 14-1/8")
 Net weight 2.3 - 2.6 kg (5.1 - 5.7 lbs.)

LXI XPT

Cordless Grass Trimmer UR100D

12V max



No load speed 10,000 min⁻¹
 Cutting width Nylon cutting head: 260 mm (10")
 Plastic blade: 230 mm (9")
 Spindle size M8 x 1.25 RH
 Adjustable w/ Nylon cutting head, BL1041B /
 handle BL1021B / BL1016: 38 / 19 / 15
 w/ Plastic blade, BL1041B / BL1021B /
 BL1016: 55 / 28 / 21
 Dimensions 835 - 1,185 x 267 x 210 - 315 mm
 (L x W x H) (32-7/8 - 46-3/4 x 10-1/2 x 8-1/4 - 12-3/8")
 Net weight 1.9 - 2.1 kg (4.3 - 4.6 lbs.)

CXI XPT



Cordless String Trimmer UR180D

18V



No load speed 7,800 min⁻¹
 Cutting width Trimmer head: 260 mm (10-1/4")
 Dimensions 1,229 - 1,433 x 267 x 186 - 257 mm
 (L x W x H) (48-1/2 - 56-1/2 x 10-1/2 x 7-3/8 - 10-1/8")
 Net weight 2.1 - 2.2 kg (4.7 - 4.8 lbs.)

Cordless String Trimmer UR140D

14.4V



No load speed 6,000 min⁻¹
 Cutting width Trimmer head: 260 mm (10-1/4")
 Dimensions 1,229 - 1,433 x 267 x 186 - 257 mm
 (L x W x H) (48-1/2 - 56-1/2 x 10-1/2 x 7-3/8 - 10-1/8")
 Net weight 2.1 kg (4.6 lbs.)

Lawn care/Grass care

Electric Grass Trimmer UR3502

Continuous rating Input	1,000W
No load speed	6,500 min ⁻¹
Cutting width	350 mm (13-3/4")
Dimensions (L x W x H)	1,630 x 380 x 300 mm
Net weight	4.9 kg (10.8 lbs.)



Electric Grass Trimmer UR3501

Continuous rating Input	1,000W
No load speed	7,500 min ⁻¹
Cutting width	350 mm (13-3/4")
Dimensions (L x W x H)	1,550 x 410 x 500 mm
Net weight	4.3 kg (9.6 lbs.)



Electric Grass Trimmer UR3500

Continuous rating Input	700W
No load speed	7,200 min ⁻¹
Cutting width	350 mm (13-3/4")
Dimensions (L x W x H)	1,550 x 410 x 500 mm
Net weight	4.3 kg (9.5 lbs.)



Electric Grass Trimmer UR2300

Continuous rating Input	1,000W
No load speed	7,800 min ⁻¹
Cutting width	230 mm (9")
Dimensions (L x W x H)	1,630 x 330 x 220 mm
Net weight	4.7 kg (10.3 lbs.)



String Trimmer UR3000

Continuous rating Input	450W
No load speed	9,000 min ⁻¹
Cutting width	300 mm (11-3/4")
Dimensions (L x W x H)	1,016~1,256 x 301 x 262 mm
Net weight	2.6 kg (5.7 lbs.)



Cordless Edger UE001G

40V max

new

Blade diameter	203 mm (8")
Max cutting depth	59 mm (2-5/16")
Spindle thread size	M10 x 1.25 LH
No load speed	0 - 4,800 min ⁻¹
Continuous use Under load:	18 min.
Under no-load:	60 min.
(Battery)	BL4050F
Dimensions (L x W x H)	1,860 x 227 x 303 mm
	(73-1/4 x 8-15/16 x 11-7/8")
Net weight	6.1 - 7.3 kg (13.4 - 16.1 lbs.)



XGT MOTOR AFT XPT



Lawn care/Grass care



Lawn care/Grass care

Cordless Multi Function Power Head UX01G

40V max



No load speed	High: 0 - 9,700 min ⁻¹ Med.: 0 - 8,200 min ⁻¹ Low: 0 - 5,700 min ⁻¹
Dimensions w/o Barrier bar (L x W x H)	w/ BL4050F: 1,027 x 225 x 209 mm (40-1/2 x 8-7/8 x 8-1/4")
Dimensions w/ Barrier bar (L x W x H)	w/ BL4050F: 1,027 x 320 x 209 mm (40-1/2 x 12-5/8 x 8-1/4")
Net weight	4.2 - 12.6 kg (9.3 - 27.8 lbs.)

XGT **BL** MOTOR **AFT** **XPT**



Cordless Multi Function Power Head DUX60

18V x2



No load speed	High: 0 - 9,700 min ⁻¹ Med.: 0 - 8,200 min ⁻¹ Low: 0 - 5,700 min ⁻¹
Dimensions (L x W x H)	1,011 x 320 x 216 mm (39-3/4 x 12-5/8 x 8-1/2")
Net weight	4.1 - 8.7 kg (8.9 - 19.2 lbs.)

LXI **BL** MOTOR **AFT** **XPT**



Cordless Multi Function Power Head DUX18

18V



No load speed	High: 0 - 9,700 min ⁻¹ Low: 0 - 6,800 min ⁻¹
Dimensions w/o Barrier bar (L x W x H)	w/ BL1830B / BL1840B / BL1850B / BL1860B: 983 x 225 x 175 mm (38-3/4 x 8-7/8 x 6-7/8")
Dimensions w/ Barrier bar (L x W x H)	w/ BL1830B / BL1840B / BL1850B / BL1860B: 983 x 318 x 175 mm (38-3/4 x 12-1/2 x 6-7/8")
Net weight	2.8 - 10.3 kg (6.2 - 22.7 lbs.)

LXI **BL** MOTOR **AFT** **XPT**





UX01G

Max Output
1.0kW



DUX60

Max Output
0.6kW



DUX18

Max Output
0.47kW



1,080 mm

Shaft extension attachment
LE400MP

For Pole saw, Pole hedge trimmer and Coffee harvester

Lawn care/
Grass care

Brushcutter

- EM402MP / EM403MP*
- EM404MP* / EM405MP*
- EM406MP*

Grass trimmer

- EM408MP
- EM409MP

Rotary Scissors

- EM407MP

Edger

- EE400MP

Pole saw

- EY402MP
- EY403MP

Hedge trimmer

- Straight:** EN410MP
- Angle adjustment:** EN401MP, EN402MP

Ground trimmer

- EN420MP
- EN421MP
- EN422MP
- EN424MP

*UX01G / DUX60 only

Straight

Angle adjustment

Angle adjustment

EN424MP



Optional attachments

Attachments		UX01G 40V max	DUX60 18V x2	DUX18 18V
Brushcutter	EM402MP ø230mm Metal blade	●	●	●
	EM403MP (Universal guard) ø420mm Nylon cutting head ø2.0	●	●	—
	EM404MP (Universal guard) ø420mm Nylon cutting head ø2.0	●	●	—
	EM405MP (Narrow guard) Universal guard ø420mm / ø2.0	●	●	—
	EM406MP (Narrow guard) Universal guard ø420mm / ø2.0	●	●	—
Grass trimmer	EM408MP (Universal guard) ø300mm Nylon cutting head ø2.0	●	●	●
	EM409MP (Narrow guard) Universal guard ø330mm / ø2.0	●	●	●
Rotary Scissors	EM407MP	●	●	●
Edger	EE400MP	●	●	●
Pole saw	EY402MP Cutting wide: 250mm	●	●	●
	EY403MP Cutting wide: 300mm	●	●	●
Hedge trimmer	EN410MP Straight	●	●	●
	EN401MP Angle adjustment	●	●	●
	EN402MP Angle adjustment	●	●	●

Attachments		UX01G 40V max	DUX60 18V x2	DUX18 18V
Ground trimmer	EN420MP Angle adjustment	●	●	●
	EN421MP Angle adjustment	●	●	●
	EN422MP Angle adjustment	●	●	●
	EN424MP	●	●	●
Weeding	WA400MP <small>new</small>	●	●	●
Cultivator	KR400MP 220mm	●	●	●
	KR401MP 160mm	●	●	●
Coffee harvester	EJ400MP	●	●	●
Power brush	BR400MP	●	●	●
Power sweep	SW400MP	●	●	●
Blower	UB400MP	●	●	●
	UB401MP Low noise	●	●	●
	UB402MP	●	●	●
Pump	PF400MP	●	●	●
Snow Blower	SN400MP <small>new</small>	●	●	●
Shaft extension attachment	LE400MP	●	●	●



Lawn care/Grass care

Cordless Grass Shear DUM604

18V



Cutting width	160 mm (6-5/16")
Depth adjustment	15 / 20 / 25 mm (9/16 / 13/16 / 1")
Strokes per minute	2,500 min ⁻¹
Continuous use	w/ BL1860B / BL1850B/ BL1840B / BL1830B / BL1820B / BL1815N: 250 / 200 / 160 / 125 / 80 / 60 min.
Dimensions (L x W x H)	337 x 177 x 131 mm (13-1/4 x 7 x 5-1/8")
Net weight	1.4 - 1.8 kg (3.2 - 3.9 lbs.)



Cordless Grass Shear DUM111

18V



Cutting width	Grass shear blade: 110 mm (4-5/16") Hedge trimmer blade: 200 mm (7-7/8")
Depth adjustment	15 / 20 / 25 mm (9/16 / 13/16 / 1")
Strokes per minute	2,500 min ⁻¹
Continuous use	w/ BL1850B/ BL1815N: 220 / 67 min.
Dimensions (L x W x H)	w/ BL1815N / BL1820B: 330 x 120 x 130 mm (13 x 4-3/4 x 5-1/8")
Net weight	1.4 - 1.8 kg (3.1 - 4.0 lbs.)



Cordless Grass Shear UM600D

12V max



Cutting width	160 mm (6-5/16")
Depth adjustment	15 / 20 / 25 mm (9/16 / 13/16 / 1")
Strokes per minute	2,500 min ⁻¹
Continuous use	w/ BL1041B / BL1021B / BL1016: 90 / 45 / 35 min.
Dimensions (L x W x H)	329 x 177 x 131 mm (13 x 7 x 5-1/8")
Net weight	1.3 - 1.5 kg (2.8 - 3.3 lbs.)



Cordless Grass Shear UM164D

10.8V



Cutting width	160 mm (6-5/16")
Depth adjustment	10 / 15 / 25 mm (3/8 / 9/16 / 1")
Strokes per minute	2,500 min ⁻¹
Dimensions (L x W x H)	292 x 178 x 130 mm (11-1/2 x 7 x 5-1/8")
Net weight	1.1 - 1.2 kg (2.5 - 2.6 lbs.)



Cordless Grass Shear UM167D

18V



Cutting width	160 mm (6-5/16")
Depth adjustment	10 / 20 / 30 mm (3/8 / 13/16 / 1-3/16")
Strokes per minute	2,500 min ⁻¹
Continuous use	w/ BL1815G: 60 min.
Dimensions (L x W x H)	343 x 176 x 130 mm (13-1/2 x 6-15/16 x 5-1/8")
Net weight	1.4 kg (3.1 lbs.)

















Lawn care/
Grass care

PRODUCTS

Tree care/Hedge care



-  Double Insulation
-  Variable Speed
-  Brake
-  Reversing
-  Reverse function for debris removal
-  Anti-restart function
-  Electronic 3-Speed
-  Torque Limiter
-  Constant Speed
-  Soft Start
-  Anti Vibration
-  Automatic Oiling
-  Chain Brake
-  Toolless blade change
-  Carrying Case

Tree care/Hedge care

Cordless Chain Saw

40V max



Captive nuts type

XGT BL MOTOR XPT



	UC005G	UC004G	UC003G	UC002G
Guide bar length	400 mm (16")	350 mm (14")	300 mm (12")	250 mm (10")
Chain speed	0 - 24.8 m/s (0 - 1,490 m/min) (0 - 4,880 FPM)	0 - 24.8 m/s (0 - 1,490 m/min) (0 - 4,880 FPM)	0 - 24.8 m/s (0 - 1,490 m/min) (0 - 4,880 FPM)	0 - 24.8 m/s (0 - 1,490 m/min) (0 - 4,880 FPM)
Chain oil tank volume	200 mL (6.8 US oz)	200 mL (6.8 US oz)	200 mL (6.8 US oz)	200 mL (6.8 US oz)
Dimensions (L x W x H)	w/o Guide bar, w/ Spike bumper, w/ BL4050F: 266 x 194 x 243 mm (10-1/2 x 7-5/8 x 9-9/16")	w/o Guide bar, w/ Spike bumper, w/ BL4050F: 266 x 194 x 243 mm (10-1/2 x 7-5/8 x 9-9/16")	w/o Guide bar, w/ Spike bumper, w/ BL4050F: 266 x 194 x 243 mm (10-1/2 x 7-5/8 x 9-9/16")	w/o Guide bar, w/ Spike bumper, w/ BL4050F: 266 x 194 x 243 mm (10-1/2 x 7-5/8 x 9-9/16")
Net weight	3.8 - 4.7 kg (8.4 - 10.4 lbs.)	3.8 - 4.7 kg (8.4 - 10.4 lbs.)	3.8 - 4.7 kg (8.4 - 10.4 lbs.)	3.8 - 4.7 kg (8.4 - 10.4 lbs.)

Cordless Chain Saw

40V max

Captive nuts type



UC006G: Carving Bar

XGT BL MOTOR XPT



UC007G: Motor Unit Only

	UC006G	UC007G
Guide bar length	250 mm (10")	250, 300, 350 mm (10, 12, 14")
Chain speed	0 - 24.8 m/s (0 - 1,490 m/min) (0 - 4,880 FPM)	0 - 24.8 m/s (0 - 1,490 m/min) (0 - 4,880 FPM)
Chain oil tank volume	200 mL (6.8 US oz)	200 mL (6.8 US oz)
Dimensions (L x W x H)	w/o Guide bar, w/ Spike bumper, w/ BL4050F: 266 x 194 x 243 mm (10-1/2 x 7-5/8 x 9-9/16")	w/o Guide bar, w/ Spike bumper, w/ BL4050F: 266 x 194 x 243 mm (10-1/2 x 7-5/8 x 9-9/16")
Net weight	3.8 - 4.7 kg (8.4 - 10.4 lbs.)	3.9 - 4.7 kg (8.6 - 10.4 lbs.)

Cordless Chain Saw

40V max

new



Captive nuts type

XGT BL MOTOR XPT



	UC026G	UC025G	UC024G
Guide bar length	400 mm (16")	350 mm (14")	300 mm (12")
Chain speed	0 - 25.5 m/s	0 - 25.5 m/s	0 - 25.5 m/s
Chain oil tank volume	200 mL (6.8 US oz)	200 mL (6.8 US oz)	200 mL (6.8 US oz)
Dimensions (L x W x H)	w/o Guide bar: 430 x 219 x 271 mm (17 x 8-5/8 x 10-5/8")	w/o Guide bar: 430 x 219 x 271 mm (17 x 8-5/8 x 10-5/8")	w/o Guide bar: 430 x 219 x 271 mm (17 x 8-5/8 x 10-5/8")
Net weight	5.1 - 5.4 kg (11.2 - 11.9 lbs.)	5.0 - 5.4 kg (11.0 - 11.9 lbs.)	4.9 - 5.3 kg (10.8 - 11.7 lbs.)

Cordless Chain Saw

40V max

new



Toolless type

XGT BL MOTOR XPT



	UC023G	UC022G	UC021G
Guide bar length	400 mm (16")	350 mm (14")	300 mm (12")
Chain speed	0 - 25.5 m/s	0 - 25.5 m/s	0 - 25.5 m/s
Chain oil tank volume	200 mL (6.8 US oz)	200 mL (6.8 US oz)	200 mL (6.8 US oz)
Dimensions (L x W x H)	w/o Guide bar: 430 x 225 x 271 mm (17 x 8-7/8 x 10-5/8")	w/o Guide bar: 430 x 225 x 271 mm (17 x 8-7/8 x 10-5/8")	w/o Guide bar: 430 x 225 x 271 mm (17 x 8-7/8 x 10-5/8")
Net weight	5.1 - 5.5 kg (11.2 - 12.1 lbs.)	5.1 - 5.4 kg (11.2 - 11.9 lbs.)	5.0 - 5.3 kg (11.0 - 11.7 lbs.)

Cordless Chain Saw

40V max



Captive nuts type

XGT BL MOTOR XPT



	UC013G	UC012G	UC011G	UC010G
Guide bar length	450 mm (18")	400 mm (16")	350 mm (14")	300 mm (12")
Chain speed	0 - 25.5 m/s (0 - 1,530 m/min) (0 - 5,020 FPM)	0 - 25.5 m/s (0 - 1,530 m/min) (0 - 5,020 FPM)	0 - 25.5 m/s (0 - 1,530 m/min) (0 - 5,020 FPM)	0 - 25.5 m/s (0 - 1,530 m/min) (0 - 5,020 FPM)
Chain oil tank volume	260 mL (8.8 US oz)	230 mL (7.8 US oz)	260 mL (8.8 US oz)	260 mL (8.8 US oz)
Dimensions (L x W x H)	w/o Guide bar: 445 x 230 x 275 mm (17-1/2 x 9 x 10-7/8")	w/o Guide bar: 446 x 233 x 274 mm (17-1/2 x 9-1/8 x 10-3/4")	w/o Guide bar: 445 x 230 x 275 mm (17-1/2 x 9 x 10-7/8")	w/o Guide bar: 445 x 230 x 275 mm (17-1/2 x 9 x 10-7/8")
Net weight	6.1 - 7.4 kg (13.4 - 16.3 lbs.)	6.0 - 6.5 kg (13.2 - 14.4 lbs.)	6.1 - 7.4 kg (13.4 - 16.3 lbs.)	6.1 - 7.4 kg (13.4 - 16.3 lbs.)

Cordless Chain Saw

40V max



Toolless type

XGT BL MOTOR XPT



	UC017G	UC016G	UC015G	UC014G
Guide bar length	450 mm (18")	400 mm (16")	350 mm (14")	300 mm (12")
Chain speed	0 - 25.5 m/s (0 - 1,530 m/min) (0 - 5,020 FPM)	0 - 25.5 m/s (0 - 1,530 m/min) (0 - 5,020 FPM)	0 - 25.5 m/s (0 - 1,530 m/min) (0 - 5,020 FPM)	0 - 25.5 m/s (0 - 1,530 m/min) (0 - 5,020 FPM)
Chain oil tank volume	260 mL (8.8 US oz)	260 mL (8.8 US oz)	260 mL (8.8 US oz)	260 mL (8.8 US oz)
Dimensions (L x W x H)	w/o Guide bar: 445 x 234 x 275 mm (17-1/2 x 9-1/4 x 10-7/8")	w/o Guide bar: 445 x 234 x 275 mm (17-1/2 x 9-1/4 x 10-7/8")	w/o Guide bar: 445 x 234 x 275 mm (17-1/2 x 9-1/4 x 10-7/8")	w/o Guide bar: 445 x 234 x 275 mm (17-1/2 x 9-1/4 x 10-7/8")
Net weight	6.2 - 7.5 kg (13.7 - 16.5 lbs.)	6.2 - 7.5 kg (13.7 - 16.5 lbs.)	6.2 - 7.5 kg (13.7 - 16.5 lbs.)	6.2 - 7.5 kg (13.7 - 16.5 lbs.)

Cordless Chain Saw

40V max



Captive nuts type, Motor Unit Only

XGT BL MOTOR XPT



	UC020G
Chain speed	0 - 25.5 m/s (0 - 1,530 m/min) (0 - 5,020 FPM)
Chain oil tank volume	260 mL (8.8 US oz)
Dimensions (L x W x H)	445 x 230 x 275 mm (17-1/2 x 9 x 10-7/8")
Net weight	6.2 - 7.4 kg (13.7 - 16.3 lbs.)

Cordless Chain Saw

18V x2



Captive nuts type

LXT BL XPT



	DUC406	DUC356	DUC306
Guide bar length	400 mm (16")	350 mm (14")	300 mm (12")
Chain speed	0 - 20 m/s (0 - 1,200 m/min) (0 - 3,940 FPM)	0 - 20 m/s (0 - 1,200 m/min) (0 - 3,940 FPM)	0 - 20 m/s (0 - 1,200 m/min) (0 - 3,940 FPM)
Chain oil tank volume	200 mL (6.8 US oz)	200 mL (6.8 US oz)	200 mL (6.8 US oz)
Dimensions (L x W x H)	w/o Guide bar: 270 x 205 x 232 mm (10-5/8 x 8-1/8 x 9-1/8")	w/o Guide bar: 270 x 205 x 232 mm (10-5/8 x 8-1/8 x 9-1/8")	w/o Guide bar: 270 x 205 x 232 mm (10-5/8 x 8-1/8 x 9-1/8")
Net weight	4.6 - 5.1 kg (10.1 - 11.1 lbs.)	4.6 - 5.1 kg (10.1 - 11.1 lbs.)	4.6 - 5.1 kg (10.1 - 11.1 lbs.)

Cordless Chain Saw

18V x2

Captive nuts type



DUC256C:
Carving Bar

LXT BL XPT



	DUC256	DUC256C
Guide bar length	250 mm (10")	250 mm (10")
Chain speed	0 - 20 m/s (0 - 1,200 m/min) (0 - 3,940 FPM)	0 - 20 m/s (0 - 1,200 m/min) (0 - 3,940 FPM)
Chain oil tank volume	200 mL (6.8 US oz)	200 mL (6.8 US oz)
Dimensions (L x W x H)	w/o Guide bar: 270 x 205 x 232 mm (10-5/8 x 8-1/8 x 9-1/8")	w/o Guide bar: 270 x 205 x 232 mm (10-5/8 x 8-1/8 x 9-1/8")
Net weight	4.6 - 5.1 kg (10.1 - 11.1 lbs.)	4.6 - 5.1 kg (10.1 - 11.1 lbs.)

Cordless Chain Saw

18V x2



Toolless type

LXT BL XPT



	DUC400	DUC353	DUC303
Guide bar length	400 mm (16")	350 mm (14")	300 mm (12")
Chain speed	0 - 20 m/s (0 - 1,200 m/min) (0 - 3,940 FPM)	0 - 20 m/s (0 - 1,200 m/min) (0 - 3,940 FPM)	0 - 20 m/s (0 - 1,200 m/min) (0 - 3,940 FPM)
Chain oil tank volume	200 mL	200 mL	200 mL
Dimensions (L x W x H)	w/o Guide bar: 443 x 215 x 235 mm (17-1/2 x 8-1/2 x 9-1/4")	w/o Guide bar: 443 x 215 x 235 mm (17-1/2 x 8-1/2 x 9-1/4")	w/o Guide bar: 443 x 215 x 235 mm (17-1/2 x 8-1/2 x 9-1/4")
Net weight	4.6 - 5.5 kg (10.2 - 12.1 lbs.)	4.6 - 5.5 kg (10.2 - 12.1 lbs.)	4.6 - 5.5 kg (10.2 - 12.1 lbs.)

Cordless Chain Saw

18V x2



Captive nuts type

LXT BL XPT



	DUC405	DUC355	DUC305
Guide bar length	400 mm (16")	350 mm (14")	300 mm (12")
Chain speed	0 - 20 m/s (0 - 1,200 m/min) (0 - 3,940 FPM)	0 - 20 m/s (0 - 1,200 m/min) (0 - 3,940 FPM)	0 - 20 m/s (0 - 1,200 m/min) (0 - 3,940 FPM)
Chain oil tank volume	200 mL	200 mL	200 mL
Dimensions (L x W x H)	w/o Guide bar: 443 x 211 x 235 mm (17-1/2 x 8-5/16 x 9-1/4") w/ Guide bar & Saw chain: 800 x 211 x 235 mm (31-1/2 x 8-5/16 x 9-1/4")	w/o Guide bar: 443 x 211 x 235 mm (17-1/2 x 8-5/16 x 9-1/4") w/ Guide bar & Saw chain: 762 x 211 x 235 mm (30 x 8-5/16 x 9-1/4")	w/o Guide bar: 443 x 211 x 235 mm (17-1/2 x 8-5/16 x 9-1/4") w/ Guide bar & Saw chain: 710 x 211 x 235 mm (28 x 8-5/16 x 9-1/4")
Net weight	4.8 - 5.5 kg (10.5 - 12.1 lbs.)	4.7 - 5.4 kg (10.4 - 11.8 lbs.)	4.6 - 5.3 kg (10.2 - 11.6 lbs.)

Cordless Chain Saw

18V

Captive nuts type



DUC254C:
Carving Bar

LXT BL XPT



	DUC254	DUC254C	DUC204
Guide bar length	250 mm (10")	250 mm (10")	200 mm (8")
Chain speed	24 m/s (1,440 m/min) (4,720 FPM)	24 m/s (1,440 m/min) (4,720 FPM)	24 m/s (1,440 m/min) (4,720 FPM)
Chain oil tank volume	140 mL (4.7 US oz)	140 mL (4.7 US oz)	140 mL (4.7 US oz)
Dimensions (L x W x H)	w/o Guide bar: 258 x 184 x 191 mm (10-1/8 x 7-1/4 x 7-1/2") w/ 25 cm (10") 90PX Sprocket nose bar: 482 x 184 x 191 mm (19 x 7-1/4 x 7-1/2")	w/o Guide bar: 258 x 184 x 191 mm (10-1/8 x 7-1/4 x 7-1/2") w/ 25 cm (10") 25AP Carving bar: 496 x 184 x 191 mm (17-1/2 x 7-1/2 x 7-1/4")	w/o Guide bar: 258 x 184 x 191 mm (10-1/8 x 7-1/4 x 7-1/2") w/ 20 cm (7-7/8") 90PX Sprocket nose bar: 417 x 184 x 191 mm (16-3/8 x 7-1/4 x 7-1/2")
Net weight	2.8 - 3.3 kg (6.2 - 7.2 lbs.)	2.8 - 3.3 kg (6.2 - 7.2 lbs.)	2.8 - 3.3 kg (6.2 - 7.2 lbs.)

Cordless Chain Saw

18V



Toolless type

LXT BL XPT



	DUC407	DUC357	DUC307
Guide bar length	400 mm (16")	350 mm (14")	300 mm (12")
Chain speed	7.7 m/s (460 m/min) (1,520 FPM)	7.7 m/s (460 m/min) (1,520 FPM)	7.7 m/s (460 m/min) (1,520 FPM)
Chain oil tank volume	150 mL (5.1 US oz)	150 mL (5.1 US oz)	150 mL (5.1 US oz)
Dimensions (L x W x H)	w/o Guide bar: 428 x 214 x 234 mm (16-7/8 x 8-3/8 x 9-1/4") w/ Guide bar & Saw chain: 796 x 214 x 234 mm (31-1/4 x 8-3/8 x 9-1/4")	w/o Guide bar: 428 x 214 x 234 mm (16-7/8 x 8-3/8 x 9-1/4") w/ Guide bar & Saw chain: 762 x 214 x 234 mm (30 x 8-3/8 x 9-1/4")	w/o Guide bar: 428 x 214 x 234 mm (16-7/8 x 8-3/8 x 9-1/4") w/ Guide bar & Saw chain: 704 x 214 x 234 mm (27-3/4 x 8-3/8 x 9-1/4")
Net weight	4.2 - 4.4 kg (9.3 - 9.7 lbs.)	4.2 - 4.4 kg (9.3 - 9.7 lbs.)	4.2 - 4.4 kg (9.3 - 9.7 lbs.)

Cordless Chain Saw

18V



Toolless type

LXT



	DUC122
Guide bar length	115 mm (4-1/2")
Chain speed	5.0 m/s (300 m/min) (980 FPM)
Chain oil tank volume	80 mL (2.7 US oz)
Dimensions (L x W x H)	w/ Guide bar & Saw chain: 422 x 195 x 215 mm (16-5/8 x 7-5/8 x 8-1/2")
Net weight	2.6 kg (5.7 lbs.)

Tree care/Hedge care

Electric Chain Saw



Toolless type

	UC4551A	UC4051A	UC3551A	UC3051A
Continuous rating Input	2,000W	2,000W	2,000W	2,000W
Guide bar length	450 mm (18")	400 mm (16")	350 mm (14")	300 mm (12")
Chain speed per minute	870 m (2,900 ft)	870 m (2,900 ft)	870 m (2,900 ft)	870 m (2,900 ft)
Dimensions (L x W x H)	505 x 200 x 220 mm (19-7/8 x 7-7/8 x 8-5/8")	505 x 200 x 220 mm (19-7/8 x 7-7/8 x 8-5/8")	505 x 200 x 220 mm (19-7/8 x 7-7/8 x 8-5/8")	505 x 200 x 220 mm (19-7/8 x 7-7/8 x 8-5/8")
Net weight	5.7 kg (12.4 lbs.)	5.6 kg (12.3 lbs.)	5.5 kg (12.1 lbs.)	5.4 kg (11.9 lbs.)



Electric Chain Saw



Captive nuts type

	UC4550A	UC4050A	UC3550A	UC3050A
Continuous rating Input	2,000W	2,000W	2,000W	2,000W
Guide bar length	450 mm (18")	400 mm (16")	350 mm (14")	300 mm (12")
Chain speed per minute	870 m (2,900 ft)	870 m (2,900 ft)	870 m (2,900 ft)	870 m (2,900 ft)
Dimensions (L x W x H)	505 x 196 x 220 mm (19-7/8 x 7-3/4 x 8-5/8")	505 x 196 x 220 mm (19-7/8 x 7-3/4 x 8-5/8")	505 x 196 x 220 mm (19-7/8 x 7-3/4 x 8-5/8")	505 x 196 x 220 mm (19-7/8 x 7-3/4 x 8-5/8")
Net weight	5.7 kg (12.5 lbs.)	5.6 kg (12.2 lbs.)	5.5 kg (12.1 lbs.)	5.4 kg (11.9 lbs.)



Electric Chain Saw



Toolless type

	UC4041A	UC3541A	UC3041A
Continuous rating Input	1,800W	1,800W	1,800W
Guide bar length	400 mm (16")	350 mm (14")	300 mm (12")
Chain speed per minute	870 m (2,900 ft)	870 m (2,900 ft)	870 m (2,900 ft)
Dimensions (L x W x H)	455 x 245 x 200 mm (17-7/8 x 9-5/8 x 7-7/8")	455 x 245 x 200 mm (17-7/8 x 9-5/8 x 7-7/8")	455 x 245 x 200 mm (17-7/8 x 9-5/8 x 7-7/8")
Net weight	4.7 kg (10.5 lbs.)	4.7 kg (10.3 lbs.)	4.6 kg (10.1 lbs.)



Cordless Pruning Saw

40V max

new



Toolless type

XGT BL XPT



	UC029G
Chain speed (at no load)	8.0 m/s
Saw chain	Type: 80TXL Pitch: 0.325" Gauge: 1.1 mm (0.043") Guide bar length: 150 mm (6")
Oil tank capacity	55 mL (1.9 oz)
Dimensions (L x W x H)	474 x 95 x 255 mm (18-5/8 x 3-3/4 x 10")
Net weight	2.1 - 2.4 kg (4.6 - 5.3 lbs.)

Cordless Pruning Saw

18V



Toolless type

LXT BL XPT



	DUC150	DUC101
Chain speed (at no load)	8.0 m/s	8.0 m/s
Saw chain	Type: 80TXL Pitch: 0.325" Gauge: 1.1 mm (0.043") Guide bar length: 150 mm (6")	Type: 80TXL Pitch: 0.325" Gauge: 1.1 mm (0.043") Guide bar length: 100 mm (4")
Chain oil tank volume	55 mL (1.9 USoz)	55 mL (1.9 USoz)
Dimensions (L x W x H)	w/ BL1830B / BL1840B / BL1850B / BL1860B: 459 x 90 x 249 mm (18 x 3-1/2 x 9-3/4")	w/ BL1830B / BL1840B / BL1850B / BL1860B: 408 x 90 x 249 mm (16 x 3-1/2 x 9-3/4")
Net weight	1.7 - 2.0 kg (3.7 - 4.4 lbs.)	1.6 - 2.0 kg (3.5 - 4.4 lbs.)

Cordless Pruning Saw

12V max



Toolless type

XT BL XPT



	UC100D
Chain speed (at no load)	8.0 m/s
Saw chain	Type: 80TXL Pitch: 0.325" Gauge: 1.1 mm (0.043") Guide bar length: 100 mm (4")
Chain oil tank volume	55 mL (1.9 USoz)
Dimensions (L x W x H)	w/ BL1041B: 398 x 90 x 226 mm (15-5/8 x 3-1/2 x 8-7/8")
Net weight	1.5 - 1.6 kg (3.3 - 3.5 lbs.)



Tree care/Hedge care

Cordless Telescopic Pole Saw

40V max



XGT **BL** **AFT** **XPT**



	UA004G	UA002G
Guide bar length	300 mm (11-3/4")	250 mm (10")
Chain speed	20.0 m/s (1,200 m/min) (3,940 FPM)	0 - 20.0 m/s (0 - 1,200 m/min) (0 - 3,940 FPM)
Oil tank capacity	160 mL	160 mL
Dimensions (L x W x H)	w/ Guide bar & Saw chain, w/ BL4050F/ BL4080F: 2,812 - 4,044 x 156 x 192 mm (110-1/2 - 159 x 6-1/8 x 7-9/16")	w/ Guide bar & Saw chain, w/ BL4050F/ BL4080F: 2,765 - 3,997 x 156 x 192 mm (109 - 3,997 x 6-1/8 x 7-9/16")
Net weight	7.8 - 9.1 kg (17.2 - 20.1 lbs.)	7.7 - 8.9 kg (17.0 - 19.6 lbs.)

Cordless Pole Saw

40V max



XGT **BL** **AFT** **XPT**



	UA003G	UA001G
Guide bar length	300 mm (12")	250 mm (10")
Chain speed	0 - 20 m/s (0 - 1,200 m/min) (0 - 3,940 FPM)	0 - 20 m/s (0 - 1,200 m/min) (0 - 3,940 FPM)
Dimensions (L x W x H)	w/o Guide bar, w/ BL4050F/ BL4080F: 2,230 x 156 x 192 mm (88 x 6-1/8 x 7-9/16") w/ Guide bar & Saw chain, w/ BL4050F/ BL4080F: 2,526 x 156 x 192 mm (99-1/2 x 6-1/8 x 7-9/16")	w/o Guide bar, w/ BL4050F/ BL4080F: 2,230 x 156 x 192 mm (88 x 6-1/8 x 7-9/16") w/ Guide bar & Saw chain, w/ BL4050F/ BL4080F: 2,470 x 156 x 192 mm (97-1/4 x 6-1/8 x 7-9/16")
Net weight	6.1 - 7.4 kg (13.4 - 16.3 lbs.)	6.0 - 7.2 kg (13.2 - 15.9 lbs.)

Cordless Telescopic Pole Saw

18V x2



LXT **BL** **AFT** **XPT**



	DUA301	DUA251
Guide bar length	300 mm (12")	250 mm (10")
Chain speed	0 - 20.0 m/s (0 - 1,200 m/min) (0 - 3,940 FPM)	0 - 20.0 m/s (0 - 1,200 m/min) (0 - 3,940 FPM)
Oil tank capacity	160 mL	160 mL
Dimensions (L x W x H)	w/ Guide bar & Saw chain: 2,826 - 4,058 x 155 x 191 mm (111 - 160 x 6-1/8 x 7-1/2")	w/ Guide bar & Saw chain: 2,770 - 4,002 x 155 x 191 mm (109 - 157-1/2 x 6-1/8 x 7-1/2")
Net weight	7.8 - 8.5 kg (17.2 - 18.7 lbs.)	7.8 - 8.4 kg (17.2 - 18.5 lbs.)

Cordless Pole Saw

18V x2



LXT **BL** **AFT** **XPT**



	DUA300	DUA250
Guide bar length	300 mm (12")	250 mm (10")
Saw chain	Pitch: 3/8" Gauge: 1.1 / 1.3 mm (0.043 / 0.050")	Pitch: 3/8" Gauge: 1.1 / 1.3 mm (0.043 / 0.050")
Chain speed	0 - 20.0 m/s (0 - 1,200 m/min) (0 - 3,940 FPM)	0 - 20.0 m/s (0 - 1,200 m/min) (0 - 3,940 FPM)
Dimensions (L x W x H)	w/o Guide bar: 2,238 x 155 x 191 mm (88 x 6-1/8 x 7-1/2") w/ Guide bar & Saw chain: 2,478 x 155 x 191 mm (97-1/2 x 6-1/8 x 7-1/2")	w/o Guide bar: 2,238 x 155 x 191 mm (88 x 6-1/8 x 7-1/2") w/ Guide bar & Saw chain: 2,478 x 155 x 191 mm (97-1/2 x 6-1/8 x 7-1/2")
Net weight	6.1 - 6.9 kg (13.5 - 15.2 lbs.)	6.1 - 6.8 kg (13.5 - 15.0 lbs.)

Cordless Pole Saw

18V

new



LXT **BL** **XPT**



	DUA200
Guide bar length	200 mm (8")
Saw chain	Type: 80TXL Pitch: 0.325" Gauge: 1.1 mm (0.043")
Chain speed	6.7 m/s
Oil tank capacity	55 mL (1.9 oz)
Dimensions (L x W x H)	1,620 - 2,520 x 85 x 134 mm (63-3/4 - 99 x 3-3/8 x 5-1/4")
Net weight	3.2 - 3.5 kg (7.1 - 7.7 lbs.)



Tree care/Hedge care

Cordless Hedge Trimmer

40V max



Sharp edge curved Blade



	UH004G	UH005G
Blade length	600 mm (23-5/8")	750 mm (29-1/2")
Strokes per minute	High / Med. / Low: 5,000 / 3,600 / 2,000 min ⁻¹	High / Med. / Low: 5,000 / 3,600 / 2,000 min ⁻¹
Tooth spacing	35 mm (1-3/8")	35 mm (1-3/8")
Max cutting capacity	23.5 mm (15/16")	23.5 mm (15/16")
Continuous use	w/ BL4040, High: 85 min. w/ BL4040, Med.: 160 min. w/ BL4040, Low: 370 min.	w/ BL4040, High: 80 min. w/ BL4040, Med.: 155 min. w/ BL4040, Low: 365 min.
Dimensions (L x W x H)	w/ BL4050F: 1,120 x 223 x 214 mm (44 x 8-3/4 x 8-3/8")	w/ BL4050F: 1,263 x 223 x 214 mm (49-3/4 x 8-3/4 x 8-3/8")
Net weight	4.3 - 4.9 kg (9.5 - 10.8 lbs.)	4.5 - 5.1 kg (9.9 - 11.2 lbs.)

Cordless Hedge Trimmer

40V max



Sharp edge Blade



	UH006G	UH007G
Blade length	600 mm (23-5/8")	750 mm (29-1/2")
Strokes per minute	High / Med. / Low: 4,000 / 3,000 / 2,000 min ⁻¹	High / Med. / Low: 4,000 / 3,000 / 2,000 min ⁻¹
Tooth spacing	38 mm (1-1/2")	38 mm (1-1/2")
Max cutting capacity	25.0 mm (1")	25.0 mm (1")
Continuous use	w/ BL4040, High: 65 min. w/ BL4040, Med.: 110 min. w/ BL4040, Low: 195 min.	w/ BL4040, High: 65 min. w/ BL4040, Med.: 105 min. w/ BL4040, Low: 185 min.
Dimensions (L x W x H)	w/ BL4050F: 1,123 x 223 x 214 mm (44-1/2 x 8-3/4 x 8-3/8")	w/ BL4050F: 1,274 x 223 x 214 mm (50-1/4 x 8-3/4 x 8-3/8")
Net weight	4.4 - 5.0 kg (9.7 - 11.0 lbs.)	4.6 - 5.2 kg (10.1 - 11.5 lbs.)

Cordless Hedge Trimmer

40V max



Standard Blade



	UH008G	UH009G
Blade length	600 mm (23-5/8")	750 mm (29-1/2")
Strokes per minute	High / Med. / Low: 5,000 / 3,600 / 2,000 min ⁻¹	High / Med. / Low: 5,000 / 3,600 / 2,000 min ⁻¹
Tooth spacing	35 mm (1-3/8")	35 mm (1-3/8")
Max cutting capacity	21.5 mm (7/8")	21.5 mm (7/8")
Continuous use	w/ BL4040, High: 80 min. w/ BL4040, Med.: 150 min. w/ BL4040, Low: 360 min.	w/ BL4040, High: 75 min. w/ BL4040, Med.: 140 min. w/ BL4040, Low: 265 min.
Dimensions (L x W x H)	w/ BL4050F: 1,120 x 223 x 214 mm (44 x 8-3/4 x 8-3/8")	w/ BL4050F: 1,262 x 223 x 214 mm (49-3/4 x 8-3/4 x 8-3/8")
Net weight	4.3 - 4.9 kg (9.5 - 10.8 lbs.)	4.5 - 5.0 kg (9.7 - 11.0 lbs.)

Cordless Hedge Trimmer

40V max



	UH020G	UH021G
Blade	Length: 500 mm (19-3/4") Tooth spacing: 30 mm (1-3/16")	Length: 600 mm (23-5/8") Tooth spacing: 30 mm (1-3/16")
No load speed	2,100 min ⁻¹	2,100 min ⁻¹
Max branch diameter	20.0 mm (13/16")	20.0 mm (13/16")
Continuous use (at no load)	110 min. BL4040	105 min. BL4040
Dimensions (L x W x H)	929 x 207 x 185 mm (36-1/2 x 8-1/8 x 7-1/4")	1,048 x 207 x 185 mm (41-1/4 x 8-1/8 x 7-1/4")
Net weight	3.0 - 4.2 kg (6.6 - 9.3 lbs.)	3.1 - 4.3 kg (6.8 - 9.5 lbs.)

Cordless Hedge Trimmer

18V



Sharp edge curved Blade



	DUH501	DUH601	DUH751
Blade length	500 mm (19-3/4")	600 mm (23-5/8")	750 mm (29-1/2")
Strokes per minute	High / Med. / Low: 0 - 4,400 / 0 - 3,600 / 0 - 2,000 min ⁻¹	High / Med. / Low: 0 - 4,400 / 0 - 3,600 / 0 - 2,000 min ⁻¹	High / Med. / Low: 0 - 4,400 / 0 - 3,600 / 0 - 2,000 min ⁻¹
Tooth spacing	35 mm (1-3/8")	35 mm (1-3/8")	35 mm (1-3/8")
Max cutting capacity	23.5 mm (15/16")	23.5 mm (15/16")	23.5 mm (15/16")
Continuous use	w/ BL1860B, High / Med. / Low: 60 / 80 / 300 min.	w/ BL1860B, High / Med. / Low: 55 / 80 / 200 min.	w/ BL1860B, High / Med. / Low: 45 / 70 / 160 min.
Dimensions (L x W x H)	1,016 x 225 x 192 mm (40 x 8-7/8 x 7-1/2")	1,121 x 225 x 192 mm (44-1/4 x 8-7/8 x 7-1/2")	1,261 x 225 x 192 mm (49-1/2 x 8-7/8 x 7-1/2")
Net weight	3.8 - 4.5 kg (8.4 - 9.8 lbs.)	3.8 - 4.5 kg (8.4 - 9.8 lbs.)	3.8 - 4.5 kg (8.4 - 9.8 lbs.)

Cordless Hedge Trimmer

18V



Standard Blade



	DUH502	DUH602	DUH752
Blade length	500 mm (19-5/8")	600 mm (23-5/8")	750 mm (29-1/2")
Strokes per minute	High / Med. / Low: 0 - 4,400 / 0 - 3,600 / 0 - 2,000 min ⁻¹	High / Med. / Low: 0 - 4,400 / 0 - 3,600 / 0 - 2,000 min ⁻¹	High / Med. / Low: 0 - 4,400 / 0 - 3,600 / 0 - 2,000 min ⁻¹
Tooth spacing	35 mm (1-3/8")	35 mm (1-3/8")	35 mm (1-3/8")
Max cutting capacity	21.5 mm (7/8")	21.5 mm (7/8")	21.5 mm (7/8")
Continuous use	w/ BL1860B, High / Med. / Low: 50 / 75 / 230 min.	w/ BL1860B, High / Med. / Low: 45 / 70 / 180 min.	w/ BL1860B, High / Med. / Low: 40 / 60 / 150 min.
Dimensions (L x W x H)	1,016 x 225 x 192 mm (40 x 8-7/8 x 7-1/2")	1,221 x 225 x 192 mm (44-1/8 x 8-7/8 x 7-1/2")	1,261 x 225 x 192 mm (49-1/2 x 8-7/8 x 7-1/2")
Net weight	3.8 - 4.5 kg (8.4 - 9.8 lbs.)	3.8 - 4.5 kg (8.4 - 9.8 lbs.)	3.8 - 4.5 kg (8.4 - 9.8 lbs.)

Cordless Hedge Trimmer

18V



	DUH506	DUH606
Blade length	500 mm (19-3/4")	600 mm (23-5/8")
Strokes per minute	4,000 min ⁻¹	4,000 min ⁻¹
Tooth spacing	30 mm (1-3/16")	30 mm (1-3/16")
Max branch diameter	20.0 mm (13/16")	20.0 mm (13/16")
Continuous use	w/ BL1860B: 75 min.	w/ BL1860B: 70 min.
Dimensions (L x W x H)	w/ BL1830B / BL1840B / BL1850B / BL1860B: 897 x 207 x 185 mm (35-1/4 x 8-1/8 x 7-1/4")	w/ BL1830B / BL1840B / BL1850B / BL1860B: 1,016 x 207 x 185 mm (40 x 8-1/8 x 7-1/4")
Net weight	2.5 - 2.9 kg (5.5 - 6.4 lbs.)	2.7 - 3.0 kg (6.0 - 6.6 lbs.)

Tree care/Hedge care

Cordless Hedge Trimmer

18V



LXT XPT



	DUH507	DUH607
Blade length	500 mm (19-3/4")	600 mm (23-5/8")
Strokes per minute	2,700 min ⁻¹	2,700 min ⁻¹
Tooth spacing	28 mm (1-1/8")	28 mm (1-1/8")
Max branch diameter	15 mm (9/16")	15 mm (9/16")
Continuous use	w/ BL1830B: 77 min.	w/ BL1830B: 60 min.
Dimensions (L x W x H)	w/ BL1830B / BL1840B / BL1850B / BL1860B: 925 x 209 x 188 mm (36-1/2 x 8-1/4 x 7-3/8")	w/ BL1830B / BL1840B / BL1850B / BL1860B: 1,029 x 209 x 188 mm (40-1/2 x 8-1/4 x 7-3/8")
Net weight	2.7 - 3.0 kg (6.0 - 6.6 lbs.)	2.8 - 3.1 kg (6.2 - 6.8 lbs.)

Cordless Hedge Trimmer

40V max



XGT BL MOTOR XPT



	UH013G	UH014G
Blade length	600 mm (23-5/8")	750 mm (29-1/2")
Strokes per minute	High / Med. / Low: 5,000 / 3,600 / 2,000 min ⁻¹	High / Med. / Low: 5,000 / 3,600 / 2,000 min ⁻¹
Tooth spacing	35 mm (1-3/8")	35 mm (1-3/8")
Max branch diameter	23.5 mm (15/16")	23.5 mm (15/16")
Continuous use	w/ BL4040, High: 85 min. w/ BL4040, Med.: 160 min. w/ BL4040, Low: 390 min.	w/ BL4040, High: 80 min. w/ BL4040, Med.: 155 min. w/ BL4040, Low: 380 min.
Dimensions (L x W x H)	w/ BL4050F: 1,085 x 270 x 168 mm (42-3/4 x 10-5/8 x 6-5/8")	w/ BL4050F: 1,225 x 270 x 168 mm (48-1/4 x 10-5/8 x 6-5/8")
Net weight	3.9 - 4.5 kg (8.6 - 9.9 lbs.)	4.0 - 4.7 kg (8.8 - 10.4 lbs.)

Cordless Hedge Trimmer

18V



LXT BL MOTOR XPT



	DUH604S	DUH754S
Blade length	600 mm (23-5/8")	750 mm (29-1/2")
Strokes per minute	High / Med. / Low: 4,400 / 3,600 / 2,000 min ⁻¹	High / Med. / Low: 4,400 / 3,600 / 2,000 min ⁻¹
Tooth spacing	35 mm (1-3/8")	35 mm (1-3/8")
Max branch diameter	23.5 mm (15/16")	23.5 mm (15/16")
Continuous use	w/ BL1860B, High / Med. / Low: 70 / 90 / 200 min.	w/ BL1860B, High / Med. / Low: 65 / 80 / 190 min.
Dimensions (L x W x H)	1,061 x 282 x 143 mm (41-3/4 x 11-1/8 x 5-5/8")	1,200 x 282 x 143 mm (47-1/4 x 11-1/8 x 5-5/8")
Net weight	3.4 - 3.9 kg (7.5 - 8.6 lbs.)	3.4 - 3.9 kg (7.5 - 8.6 lbs.)

Cordless Hedge Trimmer

12V max



CXT 2in1



	UH201D
Blade length	200 mm (7-7/8")
Strokes per minute	2,500 min ⁻¹
Tooth spacing	26 mm (1")
Continuous use	w/ BL1041B / BL1021B / BL1016: 90 / 45 / 35 min.
Dimensions (L x W x H)	504 x 120 x 131 mm (19-7/8 x 4-3/4 x 5-1/8")
Net weight	1.3 - 1.5 kg (2.9 - 3.3 lbs.)

Cordless Hedge Trimmer

10.8V



2in1



	UH200D
Blade length	200 mm (7-7/8")
Strokes per minute	2,500 min ⁻¹
Dimensions (L x W x H)	460 x 120 x 130 mm (18-1/8 x 4-3/4 x 5-1/8")
Net weight	1.1 - 1.2 kg (2.5 - 2.6 lbs.)



Tree care/
Hedge care

Tree care/Hedge care

Hedge Trimmer



	UH5580	UH6580	UH7580
Continuous rating Input	670W	670W	670W
Blade length	550 mm (21-5/8")	650 mm (25-1/2")	750 mm (29-1/2")
Strokes per minute	3,000 min ⁻¹	3,000 min ⁻¹	3,000 min ⁻¹
Dimensions (L x W x H)	970 x 223 x 206 mm (38-1/4 x 8-3/4 x 8-1/8")	1,049 x 223 x 206 mm (41-1/4 x 8-3/4 x 8-1/8")	1,157 x 223 x 206 mm (45-1/2 x 8-3/4 x 8-1/8")
Net weight	4.2 kg (9.2 lbs.)	4.3 kg (9.4 lbs.)	4.4 kg (9.7 lbs.)



Hedge Trimmer



	UH4570	UH5570	UH6570
Continuous rating Input	550W	550W	550W
Blade length	450 mm (17-3/4")	550 mm (21-5/8")	650 mm (25-1/2")
Strokes per minute	3,200 min ⁻¹	3,200 min ⁻¹	3,200 min ⁻¹
Dimensions (L x W x H)	862 x 223 x 206 mm (34 x 8-3/4 x 8-1/8")	970 x 223 x 206 mm (38-1/4 x 8-3/4 x 8-1/8")	1,042 x 223 x 206 mm (41 x 8-3/4 x 8-1/8")
Net weight	3.6 kg (8 lbs.)	3.7 - 3.8 kg (8.2 - 8.4 lbs.)	3.8 - 3.9 kg (8.4 - 8.5 lbs.)



Hedge Trimmer



	UH4261	UH4861	UH5261
Continuous rating Input	400W	400W	400W
Blade length	420 mm (16-1/2")	480 mm (18-7/8")	520 mm (20-1/2")
Strokes per minute	3,200 min ⁻¹	3,200 min ⁻¹	3,200 min ⁻¹
Dimensions (L x W x H)	821 x 194 x 194 mm (32-1/4 x 7-5/8 x 7-5/8")	871 x 194 x 194 mm (34-1/4 x 7-5/8 x 7-5/8")	921 x 194 x 194 mm (36-1/4 x 7-5/8 x 7-5/8")
Net weight	2.9 kg (6.5 lbs.)	3 kg (6.6 lbs.)	3 kg (6.7 lbs.)



Tree care/Hedge care

Cordless Pole Hedge Trimmer UN001G

40V max

new

Blade length	600 mm (23-5/8")
No load speed	Low: 1,000 min ⁻¹ / Med: 1,500 min ⁻¹ / High: 2,000 min ⁻¹
Cutting strokes per minute	Low: 2,000 min ⁻¹ / Med: 3,000 min ⁻¹ / High: 4,000 min ⁻¹
Tooth spacing	38 mm (1-1/2")
Max cutting diameter	20 mm (13/16")
Dimensions (L x W x H)	2,268 x 100 x 148 mm (89-1/2 x 3-15/16 x 5-7/8")
Net weight	4.7 - 5.9 kg (10.4 - 13.0 lbs.)



XGT BL MOTOR XPT



Cordless Hedge Trimmer DUN500W

18V

Blade length	500 mm (19-3/4")
Strokes per minute	High / Med. / Low: 4,400 / 3,600 / 2,000 min ⁻¹
Tooth spacing	35 mm (1-3/8")
Max cutting capacity	23.5 mm (15/16")
Continuous use	w/ BL1860B, High / Med. / Low: 60 / 90 / 190 min.
Dimensions (L x W x H)	2,115 x 97 x 137 mm (83-1/4 x 3-13/16 x 5-3/8")
Net weight	3.9 - 4.3 kg (8.6 - 9.5 lbs.)



LXI BL MOTOR XPT



Sharp edge curved Blade

Cordless Hedge Trimmer DUN600L

18V

Blade length	600 mm (23-5/8")
Strokes per minute	High / Med. / Low: 4,400 / 3,600 / 2,000 min ⁻¹
Tooth spacing	35 mm (1-3/8")
Max cutting capacity	23.5 mm (15/16")
Continuous use	w/ BL1860B, High / Med. / Low: 55 / 80 / 180 min.
Dimensions (L x W x H)	2,050 x 230 x 178 mm (80-1/2 x 9 x 7")
Net weight	3.7 - 4.1 kg (8.2 - 9.0 lbs.)



LXI BL MOTOR XPT



Sharp edge curved Blade

Cordless Hedge Trimmer DUN501W

18V

Blade length	500 mm (19-3/4")
Strokes per minute	High / Med. / Low: 4,400 / 3,600 / 2,000 min ⁻¹
Tooth spacing	35 mm (1-3/8")
Max cutting capacity	21.5 mm (7/8")
Continuous use	w/ BL1860B, High / Med. / Low: 55 / 80 / 170 min.
Dimensions (L x W x H)	2,115 x 97 x 137 mm (83-1/4 x 3-13/16 x 5-3/8")
Net weight	3.9 - 4.2 kg (8.6 - 9.3 lbs.)



LXI BL MOTOR XPT



Cordless Hedge Trimmer DUN601L

18V

Blade length	600 mm (23-5/8")
Strokes per minute	High / Med. / Low: 4,400 / 3,600 / 2,000 min ⁻¹
Tooth spacing	35 mm (1-3/8")
Max cutting capacity	21.5 mm (7/8")
Continuous use	w/ BL1860B, High / Med. / Low: 50 / 70 / 160 min.
Dimensions (L x W x H)	2,050 x 230 x 178 mm (80-1/2 x 9 x 7")
Net weight	3.7 - 4.1 kg (8.2 - 9.0 lbs.)



LXI BL MOTOR XPT



Cordless Pole Hedge Trimmer DUN461W

18V

Blade length	460 mm (18-1/8")
Strokes per minute	3,600 min ⁻¹
Tooth spacing	28 mm (1-1/8")
Max cutting capacity	18 mm (11/16")
Dimensions (L x W x H)	1,889 - 2,511 x 87 x 134 mm (74-1/2 - 99 x 3-7/16 x 5-1/4")
Net weight	3.0 - 3.3 kg (6.6 - 7.3 lbs.)



LXI XPT

Cordless Pole Hedge Trimmer UN460WD

12V max

Blade length	460 mm (18-1/8")
Strokes per minute	3,600 min ⁻¹
Tooth spacing	28 mm (1-1/8")
Max cutting capacity	18 mm (11/16")
Dimensions (L x W x H)	1,889 - 2,511 x 87 x 134 mm (74-1/2 - 99 x 3-7/16 x 5-1/4")
Net weight	2.8 - 3.0 kg (6.2 - 6.6 lbs.)



CXI XPT



Tree care/
Hedge care

Tree care/Hedge care

Battery Powered Pruning Shears
DUP362

18V x2



Capacity	Max cutting: 33 mm (1-5/16") Max blade opening: 54 mm
Cutting torque	250 N
Dimensions (L x W x H)	305 x 43 x 106 mm (12 x 1-11/16 x 4-3/16")
Net weight	0.77 - 0.82 kg (1.7 - 1.8 lbs.)

LXI XPT

Battery Powered Pruning Shears
DUP361

18V x2



Capacity	Max cutting: 33 mm Max blade opening: 54 mm
Cutting torque	185 N
Dimensions (L x W x H)	305 x 43 x 106 mm (12 x 1-11/16 x 4-3/16")
Net weight	0.8 kg (1.8 lbs.)

LXI XPT

Battery Powered Pruning Shears
DUP180

18V



Capacity	Max cutting: 30 mm (1-3/16")
Time from fully open to fully closed	0.3 sec
Work amount on a full battery charge	w/ BL1860B: 8,000 pcs
Dimensions (L x W x H)	296 x 40 x 99 mm (11-5/8 x 1-9/16 x 3-7/8")
Net weight	0.67 kg (1.5 lbs.)

LXI BL XPT

Cordless Pruning Shears
UP100D

12V max



Max cutting capacity	25 mm (1")
Time from fully open to fully closed	0.4 sec
Work amount on a full battery charge	w/ BL1021B: 2,200 pcs (when cutting ø15 mm branches of Japanese cypress)
Dimensions (L x W x H)	w/ BL1041B: 308 x 64 x 98 mm (12-1/8 x 2-1/2 x 3-7/8")
Net weight	0.89 - 1.1 kg (2.0 - 2.4 lbs.)

CXI BL XPT

Cordless Backpack Mist Blower
PM001G

40V max



No load speed	High: 15,800 - 25,000 min ⁻¹ Med.: 14,700 - 20,700 min ⁻¹ Low: 13,800 - 16,900 min ⁻¹
Solution tank capacity	15.0 L (507 oz)
Air volume	High: 8.6 - 14.3 m ³ /min Med.: 8.0 - 11.0 m ³ /min Low: 7.4 - 9.0 m ³ /min
Max air velocity	High: 39.5 - 64.0 m/s Med.: 36.5 - 52.0 m/s Low: 34.0 - 42.0 m/s
Max horizontal spray range	High: 14.0 m (46 ft)
Dimensions (L x W x H)	w/o Nozzle: 320 x 600 x 690 mm (12-5/8 x 23-5/8 x 27-1/4")
Net weight	13.2 - 15.7 kg (29.1 - 34.6 lbs.)

CXI BL XPT

Cordless Garden Sprayer
DUS158

18V



Solution tank	15 L (4.0 US-gal)
Max pressure	0.5 Mpa
Regular water discharge	Mist, Double outlet: 0.90 L/min Mist, Single outlet: 1.70 L/min
Continuous use (approx.) on a full battery charge	Double outlet nozzle, w/ BL1850B: 335 min. Herbicide nozzle, w/ BL1850B: 460 min.
Hose length	1.7 m (5.6 ft)
Dimensions (L x W x H)	317 x 237 x 517 mm (12-1/2 x 9-3/8 x 20-3/8")
Net weight	5.9 - 6.2 kg (13.0 - 13.7 lbs.)

LXI XPT

Cordless Garden Sprayer
DUS108

18V



Solution tank	10 L (2.6 US-gal)
Max pressure	0.5 Mpa
Regular water discharge	Mist, Double outlet: 0.90 L/min Mist, Single outlet: 1.70 L/min
Continuous use (approx.) on a full battery charge	Double outlet nozzle, w/ BL1850B: 335 min. Herbicide nozzle, w/ BL1850B: 460 min.
Hose length	1.7 m (5.6 ft)
Dimensions (L x W x H)	317 x 237 x 437 mm (12-1/2 x 9-3/8 x 17-1/4")
Net weight	5.6 - 5.9 kg (12.3 - 13.0 lbs.)

LXI XPT

Cordless Garden Sprayer
DUS054

18V



Solution tank	5 L (1.3 US-gal)
Max pressure	0.3 Mpa (3 kgf/cm ²)
Regular water discharge	Mist, Double outlet: 0.74 L/min Mist, Single outlet: 0.47 L/min
Spraying capacity on a full battery charge	Mist, Double outlet, w/ BL1830B: 170 L Stream, Double outlet, w/ BL1830B: 205 L
Spray wand length	0.5 - 0.7 m (1.8 - 2.3 ft)
Hose length	1.7 m (5.6 ft)
Dimensions (L x W x H)	343 x 182 x 368 mm (13-1/2 x 7-1/8 x 14-1/2")
Net weight	3.2 - 3.5 kg (7.1 - 7.7 lbs.)

LXI XPT

Cordless Garden Sprayer
US053D

12V max



Solution tank	5 L (1.3 US-gal)
Max pressure	0.3 Mpa (3 kgf/cm ²)
Regular water discharge	Mist, Double outlet: 0.74 L/min Mist, Single outlet: 0.47 L/min
Spraying capacity on a full battery charge	Mist, Double outlet, w/ BL1016: 60 L Stream, Double outlet, w/ BL1016: 75 L
Spray wand length	0.5 - 0.7 m (1.8 - 2.3 ft)
Hose length	1.7 m (5.6 ft)
Dimensions (L x W x H)	343 x 182 x 343 mm (13-1/2 x 7-1/8 x 13-1/2")
Net weight	2.9 - 3.0 kg (6.4 - 6.6 lbs.)

CXI XPT



PRODUCTS

Transportation



Variable Speed



Brake



Reversing



Electronic 2-Speed



Electronic 3-Speed



Constant Speed



Soft Start



Built-in Job Light

Transportation

Battery Powered Wheelbarrow DCU601

18V x2



Lift height	475 - 1,020 mm (18-3/4 - 40-1/4")
Traveling speed	Forward: 5.0 / 3.5 / 1.5 km/h Reverse: 1.0 km/h
Potential travel distance	w/ BL1860B x4: 7.2 km (4.5 mile)
Continuous use	w/ BL1860B x4: 100 min.
Max climbing capacity	12°
Dimensions (L x W x H) at its smallest:	1,400 x 730 x 820 mm (55 x 28-3/4 x 32-1/4")
Net weight	145 kg (320 lbs.)



Electric lift type

DCU601



Battery Powered Wheelbarrow DCU602

18V x2



Traveling speed	Forward: 5.0 / 3.5 / 1.5 km/h Reverse: 1.0 km/h
Potential travel distance	w/ BL1860B x4: 7.2 km (4.5 mile)
Continuous use	w/ BL1860B x4: 100 min.
Max climbing capacity	12°
Bucket capacity	Heaped capacity: 200 L
Dimensions (L x W x H) at its smallest:	1,480 x 730 x 820 mm (58-1/4 x 28-3/4 x 32-1/4")
Net weight	147 kg (324 lbs.)



Electric dump type

DCU602



Battery Powered Wheelbarrow DCU603

18V x2



Traveling speed	Forward: 5.0 / 3.5 / 1.5 km/h Reverse: 1.0 km/h
Potential travel distance	w/ BL1860B x4: 7.2 km (4.5 mile)
Continuous use	w/ BL1860B x4: 100 min.
Max climbing capacity	12°
Bucket capacity	Heaped capacity: 200 L
Dimensions (L x W x H) When carrier is installed, during operation:	1,480 x 730 x 820 - 1,030 mm (58-1/4 x 28-3/4 x 32-1/4 - 40-1/2")
Net weight	122 - 124 kg (269 - 273 lbs.)



Battery Powered Wheelbarrow DCU604

18V x2



Traveling speed	Forward: 5.0 / 3.5 / 1.5 km/h Reverse: 1.0 km/h
Potential travel distance	w/ BL1860B x4: 7.2 km (4.5 mile)
Continuous use	w/ BL1860B x4: 100 min.
Max climbing capacity	12°
Dimensions (L x W x H) When carrier is installed, during operation:	1,450-1,600 x 730-1,080 x 820-1,030 mm (57 - 63 x 28-3/4 - 42-1/2 x 32-1/4 - 40-1/2")
Net weight	119 - 120 kg (262 - 265 lbs.)



Battery Powered Wheelbarrow DCU605

18V x2



Traveling speed	Forward: 5.0 / 3.5 / 1.5 km/h Reverse: 1.0 km/h
Potential travel distance	w/ BL1860B x4: 7.2 km (4.5 mile)
Continuous use	w/ BL1860B x4: 100 min.
Max climbing capacity	12°
Bucket capacity	Full liquid capacity: 250 L
Dimensions (L x W x H) When carrier is installed, during operation:	1,440 x 730 x 820 - 1,030 mm (56-3/4 x 28-3/4 x 32-1/4 - 40-1/2")
Net weight	104 - 106 kg (229 - 234 lbs.)



Battery Powered Wheelbarrow DCU180

18V



Traveling speed	Forward, High / Low: 0 - 3.5 / 0 - 1.5 km/h Reverse: 0 - 1 km/h
Max run time	w/ BL1860B x2: 120 min.
Max climbing capacity	12°
Dimensions (L x W x H) When carrier is installed, during operation:	1,315 x 1,060 x 900 mm (51-3/4 x 41-3/4 x 35-1/2")
Net weight	39.3 - 44.8 kg (86.5 - 98.7 lbs.)



Transportation



PRODUCTS

Measuring/Leveling



Carrying Case

Measuring/Leveling

Rechargeable Green Multi Line Laser SK700GD

12V max



Light output power	Less than 2.0 mW
Laser type	Laser class 2: 510 - 530 nm
Number of laser lines	8 (4V4H)
Line width	at 5 m: 2.0 mm
Leveling accuracy	±2 mm / 10 m
Self-leveling range	±4°
Operating temperature	-10 - 50°C
Operating time (approx. hours)	w/ BL1016: 5 w/ BL1021B: 7 w/ BL1041B: 14
Dimensions (L x W x H)	w/ BL1041B: 168 x 104 x 153 mm (6-5/8 x 4-1/8 x 6")
Net weight	0.99 - 1.2 kg (2.2 - 2.7 lbs.)

CXI XPT



Rechargeable Red Multi Line Laser SK700D

12V max



Light output power	Less than 2.0 mW
Laser type	Laser class 2: 630 - 645 nm
Number of laser lines	8 (4V4H)
Line width	at 5 m: 2.0 mm
Leveling accuracy	±2 mm / 10 m
Self-leveling range	±4°
Operating temperature	-10 - 50°C
Protection class	IP54
Operating time (approx. hours)	w/ BL1016: 8 w/ BL1021B: 11 w/ BL1041B: 22
Dimensions (L x W x H)	w/ BL1041B: 168 x 104 x 153 mm (6-5/8 x 4-1/8 x 6")
Net weight	0.99 - 1.2 kg (2.2 - 2.7 lbs.)

CXI XPT



Rechargeable Green Multi Line Laser SK312GD

12V max



Laser type	Laser class 2: 515 nm
Number of laser lines	4 (3V1H)
Laser fan angle	Horizontal: 110° Vertical: 130°
Leveling accuracy	±1 mm / 10 m
Self-leveling range	±2°
Operating temperature	-10 - 40°C
Tripod thread	5/8"
Operating time (approx. hours)	10 - 28
Dimensions (L x W x H)	w/ BL1041B: 122 x 130 x 225 mm
Net weight	1.5 - 1.6 kg (3.3 - 3.5 lbs.)

CXI XPT

Rechargeable Green Multi Line Laser SK209GD

12V max



Laser type	Laser class 2: 515 nm
Number of laser lines	3 (2V1H)
Laser fan angle	Horizontal: 110° Vertical: 130°
Leveling accuracy	±1 mm / 10 m
Self-leveling range	±2°
Operating temperature	-10 - 40°C
Tripod thread	5/8"
Operating time (approx. hours)	15 - 40
Dimensions (L x W x H)	w/ BL1041B: 122 x 130 x 225 mm
Net weight	1.5 - 1.6 kg (3.3 - 3.5 lbs.)

CXI XPT

Rechargeable Green Multi Line Laser SK40GD

12V max



Laser type	Laser class 2: 515 nm
Number of laser lines	5 (4V1H)
Accuracy	2-vertical line: 90°±/-0.01° Line width: 3.0 mm at 10 m Plumb point laser diameter: 1.5 mm
Self-leveling range	±4°
Operating temperature	-10 - 40°C
Operating time (approx. hours)	w/ BL1016: 6
Dimensions (D x H)	98 x 223 mm
Net weight	1.4 - 1.6 kg (3.1 - 3.5 lbs.)

CXI XPT



Rechargeable Green Multi Line Laser SK20GD

12V max



Laser type	Laser class 2: 515 nm
Number of laser lines	3 (2V1H)
Accuracy	2-vertical line: 90°±/-0.01° Line width: 3.0 mm at 10 m Plumb point laser diameter: 1.5 mm
Self-leveling range	±4°
Operating temperature	-10 - 40°C
Operating time (approx. hours)	w/ BL1016: 9
Dimensions (D x H)	98 x 223 mm
Net weight	1.4 - 1.6 kg (3.1 - 3.5 lbs.)

CXI XPT



Rechargeable Green Multi Line Laser SK10GD

12V max



Laser type	Laser class 2: 515 nm
Number of laser lines	2 (1V1H)
Accuracy	2-vertical line: 90°±/-0.01° Line width: 3.0 mm at 10 m Plumb point laser diameter: 1.5 mm
Self-leveling range	±4°
Operating temperature	-10 - 40°C
Operating time (approx. hours)	w/ BL1016: 12
Dimensions (D x H)	98 x 223 mm
Net weight	1.4 - 1.6 kg (3.1 - 3.5 lbs.)

CXI XPT



Rechargeable Green 4-point Cross Line Laser SK106GD

12V max



Laser type	Laser class 2: 525 nm
Number of laser lines	2 (1V1H)
Number of laser points	4
Laser fan angle	Horizontal: 180° / Vertical: 170°
Measuring range	Up to: 35 m
Measuring range w/ detector	Up to: 80 m
Self-leveling range	±4°
Leveling accuracy	±3 mm / 10 m
Operating temperature	-10 - 50°C
Operating time (approx. hours)	7 - 20
Dimensions (L x W x H)	w/ BL1041B: 157 x 64 x 102 mm (6-3/16 x 2-1/2 x 4")
Net weight	0.69 - 0.85 kg (1.5 - 1.9 lbs.)

CXI XPT

Rechargeable Red 4-point Cross Line Laser SK106D

12V max



Laser type	Laser class 2: 635 nm
Number of laser lines	2 (1V1H)
Number of laser points	4
Laser fan angle	Horizontal: 180° / Vertical: 170°
Measuring range	Up to: 25 m
Measuring range w/ detector	Up to: 80 m
Leveling accuracy	±3 mm / 10 m
Self-leveling range	±4°
Operating temperature	-10 - 50°C
Operating time (approx. hours)	15 - 40
Dimensions (L x W x H)	w/ BL1041B: 157 x 64 x 102 mm (6-3/16 x 2-1/2 x 4")
Net weight	0.69 - 0.85 kg (1.5 - 1.9 lbs.)

CXI XPT



Measuring/Leveling

Rechargeable Green Cross Line Laser SK105GD

12V max



Laser type	Laser class 2: 525 nm
Number of laser lines	2 (1V1H)
Laser fan angle	Horizontal: 180°, Vertical: 160°
Measuring range	Up to: 35 m
Measuring range w/ detector	Up to: 80 m
Leveling accuracy	±3 mm / 10 m
Self-leveling range	±4°
Operating temperature	-10 - 50°C
Operating time (approx. hours)	7 - 20
Dimensions (L x W x H)	w/ BL1041B: 157 x 64 x 102 mm (6-3/16 x 2-1/2 x 4")
Net weight	0.67 - 0.84 kg (1.5 - 1.9 lbs.)



Rechargeable Red Cross Line Laser SK105D

12V max



Laser type	Laser class 2: 635 nm
Number of laser lines	2 (1V1H)
Laser fan angle	Horizontal: 180°, Vertical: 160°
Measuring range	Up to: 25 m
Measuring range w/ detector	Up to: 80 m
Leveling accuracy	±3 mm / 10 m
Self-leveling range	±4°
Operating temperature	-10 - 50°C
Operating time (approx. hours)	15 - 40
Dimensions (L x W x H)	w/ BL1041B: 157 x 64 x 102 mm (6-3/16 x 2-1/2 x 4")
Net weight	0.67 - 0.84 kg (1.5 - 1.9 lbs.)



Rechargeable Rotary Laser SKR001

40V max

18V

12V max

new



Operating range	Rotating beam (diameter): 800 m Plumb beam (up to): 30 m
Rotation speed	300, 450, 600 min ⁻¹
Leveling accuracy	Horizontal: 0.5 mm / 10 m Vertical: 0.75 mm / 10 m
Leveling range	5°
Continuous use	w/ BL4040: 180 hours w/ BL1860B: 135 hours w/ BL1041B: 55 hours
Net weight	4.2 - 4.9 kg (9.2 - 10.8 lbs.)



Laser Level SKR200Z



Laser type	Laser class 2: 620 - 690 nm
Operating range	Rotating beam (diameter): 200 m Plumb beam (up to): 30 m
Rotation speed	0, 300, 450, 600 min ⁻¹
Leveling accuracy	1 mm / 10 m
Leveling range	6°
Operating time (approx. hours)	60
Power supply	Cell battery: 2 pcs
Net weight	1.6 kg (3.5 lbs.)



Laser line



SK700GD

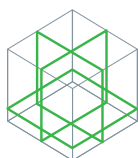

SK700D

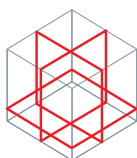

SK312GD

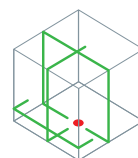

SK209GD

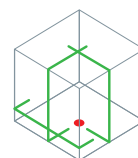

SK40GD

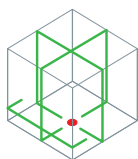

SK20GD

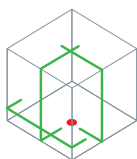

SK10GD

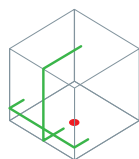

SK106GD

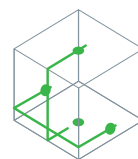

SK106D

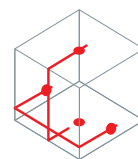

SK105GD

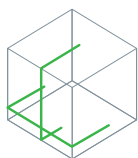

SK105D

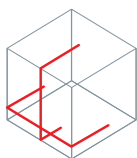

SKR001

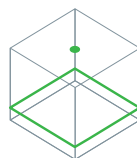

SKR200Z

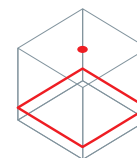

Measuring/Leveling

Laser Distance Measure LD030P



Laser type	Laser class 2: 635 nm
Measuring range	0.2 - 30 m
Operating temperature	0 - 40°C
Storage temperature	-25 - 70°C
Typical measuring tolerance	2.0 mm / 10 m
Max measuring tolerance	3.0 mm / 10 m
Diameter of laser point	6 mm 10 m
Dimensions (H x D x W)	117 x 53 x 25 mm (4.5 x 2.14 x 1")
Net weight	0.1 kg (0.22 lbs.)

Laser Distance Measure LD050P



Laser type	Laser class 2: 635 nm
Measuring range	0.05 - 50 m
Power supply	Cell battery: AAA 1.5V x 2 pcs
Net weight	0.1 kg (0.22 lbs.)

Laser Distance Measure LD080P



Laser type	Laser class 2: 635 nm
Measuring range	0.05 - 80 m
Power supply	Cell battery: AAA 1.5V x 2 pcs
Net weight	0.14 kg (0.31 lbs.)

Laser Distance Measure LD080PI



Laser type	Laser class 2: 635 nm
Measuring range	0.05 - 80 m
Power supply	Cell battery: AAA 1.5V x 2 pcs
Net weight	0.14 kg (0.31 lbs.)



PRODUCTS

Lights



Double Insulation



Soft Start



Carrying Case

Lighting coverage*

Long-distance irradiation

640m

Spot mode

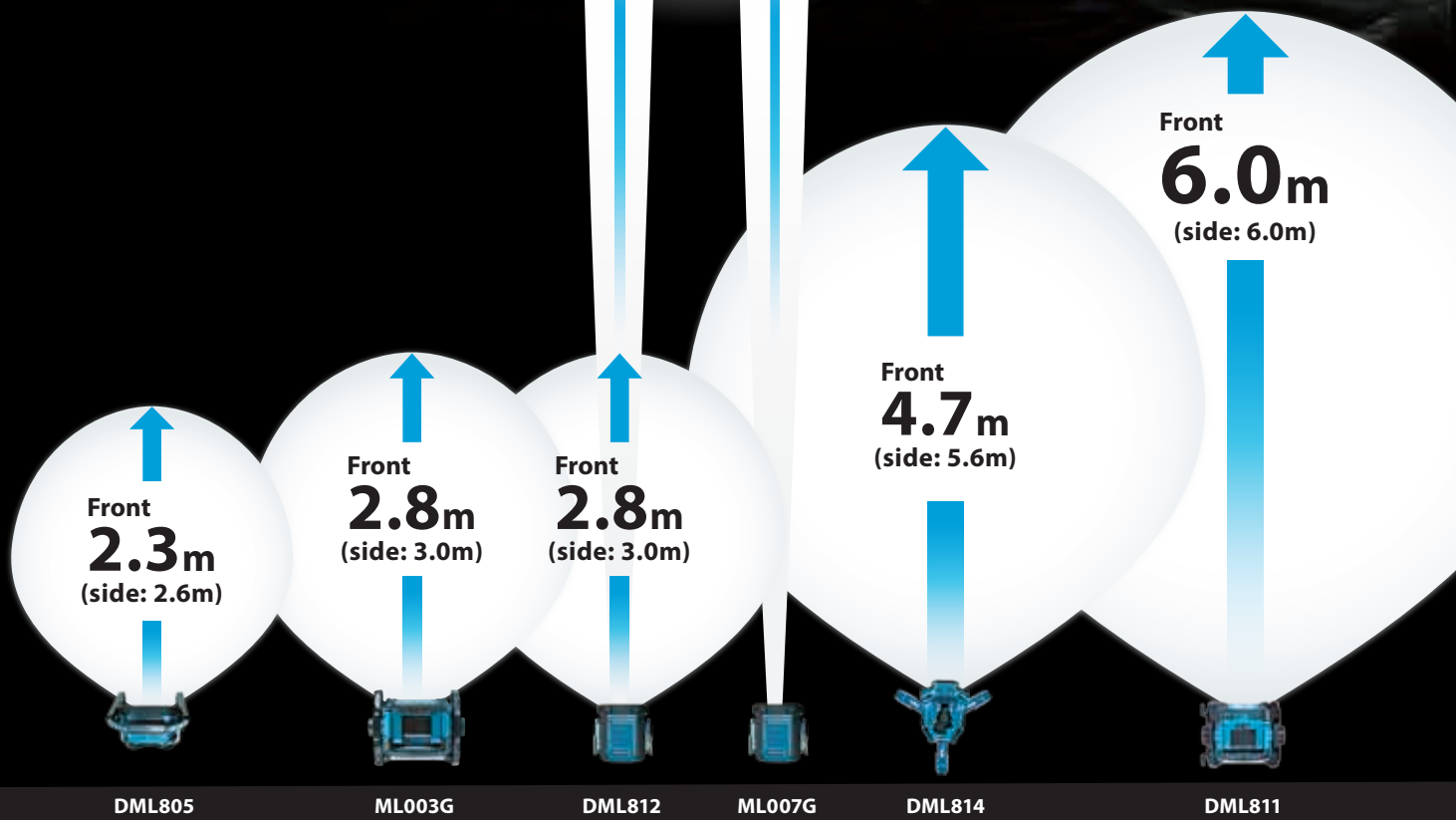

*measured in accordance with ANSI

Luminous flux



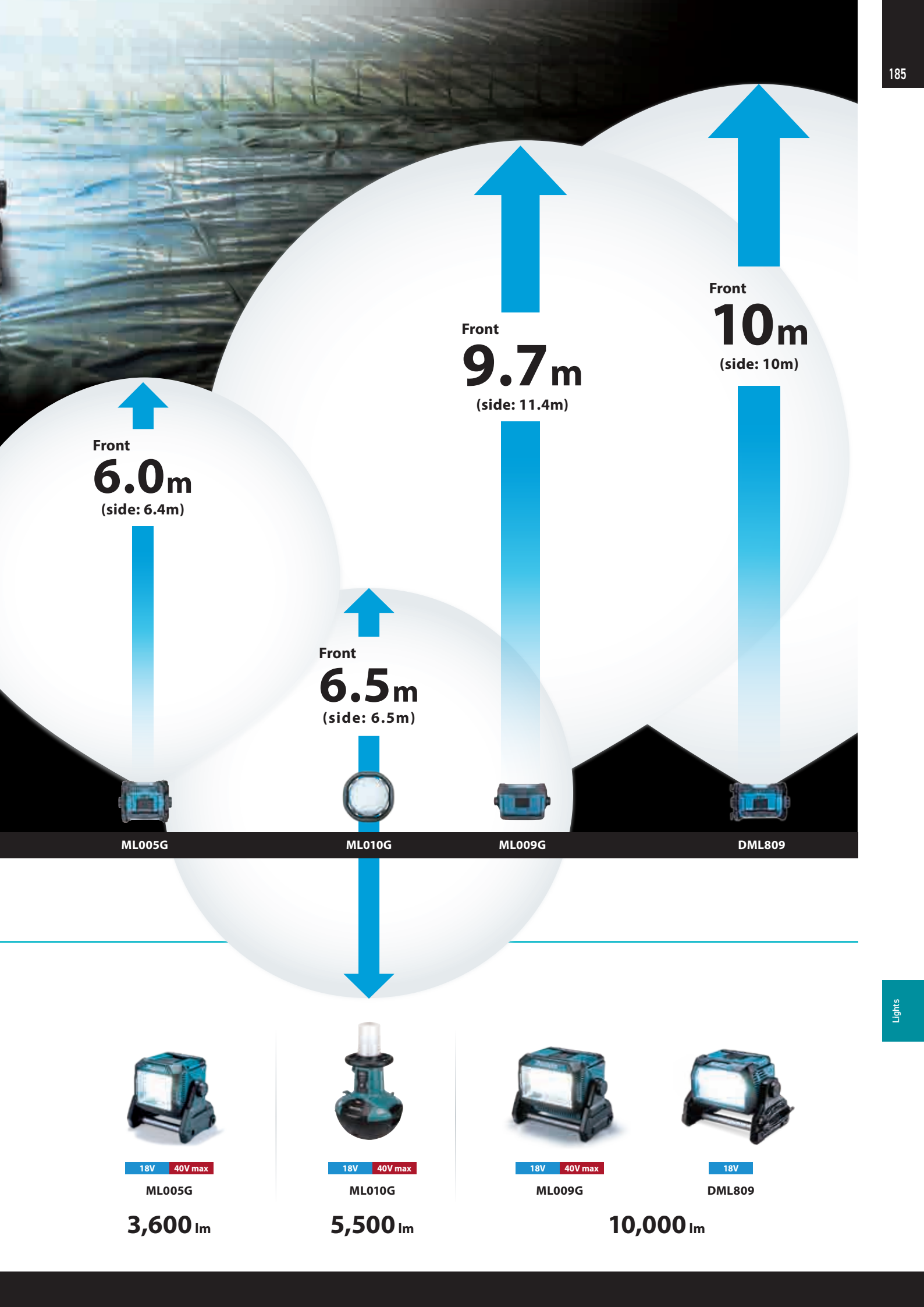

Front
6.0m
(side: 6.4m)



ML005G

Front
6.5m
(side: 6.5m)



ML010G

Front
9.7m
(side: 11.4m)



ML009G

Front
10m
(side: 10m)



DML809



18V 40V max

ML005G

3,600 lm



18V 40V max

ML010G

5,500 lm



18V 40V max

ML009G







10,000 lm









18V

DML809





Product Comparison List





	Cordless Worklight	Cordless Bar Light	Cordless Area Worklight
	DML814  18V Spot lighting / Area lighting 	ML012G  40V max	DML818  18V
	ML010G  40V max 18V 		
Run time (hrs)	w/ BL1850B Low / Mid / High: 10 / 5.5 / 3	w/ BL4040 Low / Mid / High: 32 / 15 / 7	w/ BL1860B Low / Mid / High: 23 / 11 / 5
Illuminance	at 1 m from the light source High / Mid / Low: 1,250 / 750 / 400 lx	at 1 m from the light source High / Mid / Low: 600 / 300 / 100 lx	at 1 m from the light source High / Mid / Low: 600 / 300 / 100 lx
Luminous flux	High / Mid / Low: 3,000 / 1,700 / 900 lm	High / Med. / Low: 1,700 / 800 / 400 lm	High / Med. / Low: 1,700 / 800 / 400 lm
Dimensions (L x W x H)	Operating position (Max height): 573 x 658 x 1,250 - 2,240 mm (22-1/2 x 26 x 49-1/4 - 88")	w/o Battery: 972 x 85 x 100 mm (38-1/4 x 3-3/8 x 3-15/16")	w/o Battery: 972 x 80 x 101 mm (38-1/4 x 3-1/8 x 4")
Net weight	7.4 - 8.1 kg (16.3 - 17.9 lbs.)	2.0 kg (4.4 lbs.)	1.7 kg (3.7 lbs.)



	Cordless Worklight	Cordless Worklight	Cordless Worklight	Cordless Worklight
	ML009G  40V max 18V	ML005G  40V max 18V	ML003G  40V max 18V	DML809  18V 
Run time (hrs)	w/ BL4040 x2 Low/Mid/High: 14 / 6.5 / 2.4	w/ BL4040 Low/Mid/High: 15 / 7.5 / 3.5	w/ BL4040 Low / High: 22 / 10	w/ BL1850B Low / Mid / High: 7.5 / 3.5 / 1.4
Illuminance	at 1 m from the light source High / Mid / Low: 4,300 / 1,900 / 1,000 lx	at 1 m from the light source High / Mid / Low: 2,100 / 1,000 / 500 lx	at 1 m from the light source High / Low: 500 / 200 lx	at 1 m from the light source High / Mid / Low: 3,800 / 1,500 / 800 lx
Luminous flux	High / Mid / Low: 10,000 / 4,000 / 2,000 lm	High / Mid / Low: 3,600 / 1,800 / 900 lm	High / Low: 1,100 / 450 lm	High / Mid / Low: 10,000 / 4,000 / 2,000 lm
Dimensions (L x W x H)	w/ Handle in upright position: 248 x 386 x 430 mm (9-3/4 x 15-1/4 x 17")	w/ Handle in upright position: 248 x 309 x 423 mm (9-3/4 x 12-1/8 x 16-5/8")	w/ Handle in upright position: 249 x 298 x 386 mm (9-3/4 x 11-3/4 x 15-1/4")	w/ Handle in upright position: 249 x 370 x 370 mm (9-3/4 x 14-1/2 x 14-1/2")
Net weight	6.4 - 9.9 kg (14.1 - 21.8 lbs.)	4.9 - 6.5 kg (10.8 - 14.3 lbs.)	3.7 - 4.7 kg (8.2 - 10.4 lbs.)	5.7 - 7.0 kg (12.6 - 15.4 lbs.)

	Cordless Worklight	Corded and Cordless LED Worklight	Cordless Flashlight	Cordless Flashlight
	DML811  18V 	DML805  18V 	ML007G  40V max	DML812  18V
Run time (hrs)	w/ BL1850B Low / Mid / High: 11 / 5.5 / 2.7	w/ BL1850B Low / High: 17 / 8.5	w/ BL4040 Spot mode/ Spot-Flood mode/ Flood mode/ Strobe mode: 10 / 7.5 / 10 / 10	w/ BL1850B Spot / Flood / Spot-Flood / Strobe: 8.5 / 6.5 / 5.0 / 7.0
Illuminance	at 1 m from the light source High / Mid / Low: 1,800 / 800 / 350 lx	at 1 m from the light source High / Low: 300 / 200 lx	Spot / Flood / Spot-Flood High / Mid / Low: 82,000 / 520 / 60,000 lx	Spot / Flood / Spot-Flood High / Mid / Low: 71,000 / 520 / 51,000 lx
Luminous flux	High / Mid / Low: 3,000 / 1,500 / 750 lm	High / Low: 750 / 450 lm	Spot / Flood / Spot-Flood: 600 / 1,000 / 1,250 lm	Spot / Flood / Spot-Flood: 600 / 1,000 / 1,250 lm
Dimensions (L x W x H)	w/ Handle in upright position: 249 x 302 x 361 mm (9-3/4 x 11-7/8 x 14-1/4")	214 x 261 x 328 mm (8-3/8 x 10-1/4 x 12-7/8")	w/ BL4040: 330 x 120 x 133 mm (13 x 4-3/4 x 5-1/4")	w/ BL1830B / BL1840B / BL1850B / BL1860B: 313 x 119 x 115 mm (12-3/8 x 4-11/16 x 4-1/2")
Net weight	4.1 - 4.8 kg (9.0 - 10.5 lbs.)	2.3 - 2.7 kg (5.1 - 5.9 lbs.)	1.6 - 2.9 kg (3.5 - 6.4 lbs.)	1.2 - 1.6 kg (2.6 - 3.4 lbs.)

Product Comparison List



	LED Flashlight		Rechargeable Flashlight	Cordless Flashlight
	ML001G 40V max 	DML802 18V 	DML185 18V 	DML808 18V 
Run time (hrs)	w/ BL4040: 55	w/ BL1860B: 27	w/ BL1830B: 4	w/ BL1860B: 32
Illuminance	at 1m from the light source: 3,000 lx	at 1m from the light source: 4,000 lx	at 1m from the light source: 4,500 lx	at 1m from the light source: 170 - 4,500 lx
Luminous flux	160 lm	180 lm	180 lm	190 lm
Dimensions (L x W x H)	w/ BL4040: 287 x 88 x 136 mm (11-1/4 x 3-1/2 x 5-3/8")	w/ BL1830B / BL1840B / BL1850B / BL1860B: 272 x 79 x 116 mm (10-3/4 x 3-1/8 x 4-9/16")	w/o Battery: 284x84x96 mm (11-1/8x3-5/16x3-3/4")	w/ BL1830B / BL1840B / BL1850B / BL1860B: 297 x 79 x 119 mm (11-3/4 x 3-1/8 x 4-11/16")
Net weight	0.28 - 1.3 kg (0.62 - 2.9 lbs.)	0.64 - 1 kg (1.4 - 2.2 lbs.)	0.71 - 1.03 kg (1.6 - 2.3 lbs.)	0.73 - 1.09 kg (1.6 - 2.4 lbs.)





	Cordless Worklight	Cordless LED Worklight		
	ML002G 40V max USB 	DML807 18V USB 	DML806 18V 	ML104 12V max USB 
Run time (hrs)	w/ BL4040 Main(Full) / Sub (on top): 16 / 51	w/ BL1850B Main(Full) / Sub (on top): 11 / 36	w/ BL1850B Main(Full) / Sub (on top): 11 / 59	w/ BL1041B Main(Full) / Sub (on top): 5.5 / 19
Illuminance	Main(Full / Half): 340 / 310 lx / Sub(on top side): 1,900 lx	Main(Full / Half): 340 / 310 lx / Sub(on top side): 1,900 lx	Main(Full / Half): 310 / 280 lx / Sub (on top): 2,100 lx	Main(Full): 340 lx / Sub(on top side): 1,900 lx
Luminous flux	Main(Full / Half): 710 / 340 lm / Sub(on top side): 130 lm	Main(Full / Half): 710 / 340 lm / Sub(on top side): 130 lm	Main(Full / Half): 620 / 310 lm / Sub (on top): 90 lm	Main(Full): 710 lm / Sub(on top side): 130 lm
Dimensions (L x W x H)	w/ BL4040, w/ Hook retracted: 376 x 86 x 141 mm (14-3/4 x 3-3/8 x 5-9/16")	414 x 79 x 155 mm (16-1/4 x 3-1/8 x 6-1/8")	365 x 78 x 119 mm (14-3/8 x 3-1/16 x 4-11/16")	414 x 66 x 132 mm (16-1/4 x 2-5/8 x 5-3/16")
Net weight	1.2 - 1.5 kg (2.6 - 3.3 lbs.)	0.72 - 1.1 kg (1.6 - 2.4 lbs.)	0.69 - 1.1 kg (1.5 - 2.4 lbs.)	0.61 - 0.78 kg (1.4 - 1.7 lbs.)

	Cordless Flashlight		
	ML006G 40V max 	DML816 18V 	DML801 18V 
Run time (hrs)	w/ BL4040 Low / Mid / High: 82 / 40 / 20	w/ BL1860B Low / Mid / High: 75 / 34 / 17	w/ BL1860B Full / Half: 20 / 48
Illuminance	at 0.5m from the light source High / Mid / Low: 800 / 400 / 180 lx	at 0.5m from the light source High / Mid / Low: 800 / 400 / 180 lx	at 0.5m from the light source Full / Half: 400 / 200 lx
Luminous flux	High / Mid / Low: 500 / 250 / 100 lm	High / Mid / Low: 500 / 250 / 100 lm	Full / Half: 240 / 120 lm
Dimensions (L x W x H)	w/ BL4025: 402 x 85 x 134 mm (15-3/4 x 3-3/8 x 5-1/4")	w/ BL1830B / BL1840B / BL1850B / BL1860B: 267 - 400 x 79 x 127 mm (10-1/2 - 15-3/4 x 3-1/8 x 5")	380 x 79 x 116 mm (15 x 9-11/16 x 4-9/16")
Net weight	1.1 - 1.7 kg (2.4 - 3.8 lbs.)	0.70 - 1.1 kg (1.5 - 2.4 lbs.)	0.61 - 0.98 kg (1.4 - 2.2 lbs.)

Light

Product Comparison List







	Rechargeable Flashlight	LED Flashlight
	DML800 18V 	DML803 18V 
Run time (hrs)	w/ BL1830B: 20	w/ BL1830B Low / High: 24 / 16
Illuminance	at 0.5m from the light source: 2,000 lx	at 0.5m from the light source High / Low: 270 / 180 lx
Luminous flux	100 lm	High / Low: 170 / 120 lm
Dimensions (L x W x H)	151 x 76 x 88 mm (5-15/16 x 3 x 3-1/2")	133 x 81 x 72 mm (5-1/4 x 3-3/16 x 2-13/16")
Net weight	0.53 - 0.91 kg (1.2 - 2 lbs.)	0.56 - 0.92 kg (1.2 - 2.1 lbs.)

	Cordless Worklight			Rechargeable LED Lantern
	ML011G 40V max USB 	DML817 18V USB 	ML107 12V max USB 	ML102 10.8V 7.2V 
Run time (hrs)	w/ BL4040 Full / Half: 37 / 64	w/ BL1860B Full / Half: 28 / 49	w/ BL1041B Full / Half: 17 / 29	w/ BL1013: 8
Illuminance	at 0.5 m from the light source, Sidelighting + Uplighting / Sidelighting only / Uplighting only: 240 / 190 / 190 lx	at 0.5 m from the light source, Sidelighting + Uplighting / Sidelighting only / Uplighting only: 240 / 190 / 190 lx	at 0.5 m from the light source, Sidelighting + Uplighting / Sidelighting only / Uplighting only: 175 / 130 / 130 lx	-
Luminous flux	Sidelighting + Uplighting / Sidelighting only / Uplighting only: 300 / 150 / 150 lm	Sidelighting + Uplighting / Sidelighting only / Uplighting only: 300 / 150 / 150 lm	Sidelighting + Uplighting / Sidelighting only / Uplighting only: 200 / 100 / 100 lm	-
Dimensions (L x W x H)	w/ BL4020/BL4025: 126 x 77 x 98 mm (5 x 3 x 3-7/8")	w/ BL1830(B)/BL1840(B)/ BL1850(B)/BL1860B: 123 x 77 x 96 mm (4-7/8 x 3 x 3-3/4")	w/ BL1041B: 98 x 64 x 91 mm (3-7/8 x 2-1/2 x 3-5/8")	65 x 65 x 180 mm (2-9/16 x 2-9/16 x 7-1/8")
Net weight	0.88 - 2.1 kg (1.9 - 4.6 lbs.)	0.51 - 0.88 kg (1.1 - 1.9 lbs.)	0.34 - 0.51 kg (0.75 - 1.1 lbs.)	0.32 - 0.38 kg (0.7 - 0.9 lbs.)

PRODUCTS

Comfort/Lifestyle







-  Variable Speed
-  Electronic 2-Speed
-  Electronic 3-Speed
-  Electronic 4-Speed
-  Constant Speed
-  Built-in Job Light
-  Carrying Case

Product Comparison List

	Job Site Radio			
	MR007G  40V max 18V 12V max Bluetooth DAB+ DC AC	MR006G  40V max 18V 12V max Bluetooth DC AC	MR004G  40V max 18V 12V max Bluetooth DAB+ DC AC	MR003G  40V max 18V 12V max DAB+ DC AC
Run time (hrs)	w/ BL1041B: 14 / w/ BL1850(B): 17 / w/ BL4040: 19	w/ BL1041B: 16 / w/ BL1850(B): 17 / w/ BL4040: 19	w/ BL4040: 30 / w/ BL1850B: 26 / w/ BL1041B: 21	w/ BL4040: 34 / w/ BL1850B: 29 / w/ BL1041B: 23.5
Frequency band	FM / DAB / DAB+: 87.5 - 108 MHz / 174.928 - 239.200 MHz / 174.928 - 239.200 MHz	FM / AM: 87.5 - 108 MHz / 522 - 1,710 kHz	FM / DAB / DAB+: 87.5 - 108 MHz / 174.928 - 239.200 MHz / 174.928 - 239.200 MHz	FM / DAB / DAB+: 87.5 - 108 MHz / 174.928 - 239.200 MHz / 174.928 - 239.200 MHz
Speaker Size	Sides: Dia. 63.5 mm x2 / Bottom: Dia. 101.6 mm	Sides: Dia. 63.5 mm x2 / Bottom: Dia. 101.6 mm	Dia. 89 mm x2	Dia. 89 mm x2
Dimensions (L x W x H)*1	285 x 172 x 441 mm (11-1/4 x 6-3/4 x 17-3/8")	285 x 172 x 441 mm (11-1/4 x 6-3/4 x 17-3/8")	280 x 171 x 434 mm (11 x 6-3/4 x 17-1/8")	280 x 171 x 434 mm (11 x 6-3/4 x 17-1/8")
Net weight	5.5 - 6.3 kg (12.1 - 13.9 lbs.)	5.6 - 6.4 kg (12.3 - 14.1 lbs.)	4.6 - 5.4 kg (10.1 - 11.9 lbs.)	4.6 - 5.4 kg (10.1 - 11.9 lbs.)

*1 with Handle in upright position





	Job Site Radio		Job Site Charger Radio	
	MR002G  40V max 18V 12V max Bluetooth DC AC	MR001G  40V max 18V 12V max DC AC	DMR301  18V 12V max Bluetooth DAB+ DC AC	DMR300  18V 12V max Bluetooth
Run time (hrs)	w/ BL4040: 27.5 / w/ BL1850B: 23 / w/ BL1041B: 18.5	w/ BL4040: 30 / w/ BL1850B: 25.5 / w/ BL1041B: 19.5	w/ BL1850B: 20.5 / w/ BL1041B: 16.4	w/ BL1850B: 20.5 / w/ BL1041B: 16.4
Frequency band	FM / AM: 87.5 - 108 MHz / 522 - 1,710 kHz	FM / AM: 87.5 - 108 MHz / 522 - 1,710 kHz	FM / DAB / DAB+: 87.5 - 108 MHz / 174.928 - 239.200 MHz / 174.928 - 239.200 MHz	FM / AM: 87.5 - 108 MHz / 522 - 1,710 kHz
Speaker Size	Dia. 89 mm x2	Dia. 89 mm x2	Dia. 89 mm x2	Dia. 89 mm x2
Dimensions (L x W x H)*1	280 x 171 x 434 mm (11 x 6-3/4 x 17-1/8")	280 x 171 x 434 mm (11 x 6-3/4 x 17-1/8")	268 x 185 x 427 mm (10-1/2 x 7-1/4 x 16-3/4")	268 x 185 x 427 mm (10-1/2 x 7-1/4 x 16-3/4")
Net weight	4.5 - 5.3 kg (9.9 - 11.7 lbs.)	4.5 - 5.3 kg (9.9 - 11.7 lbs.)	6.1 - 6.6 kg (13.5 - 14.6 lbs.)	6.1 - 6.6 kg (13.5 - 14.6 lbs.)

*1 with Handle in upright position

	Job Site Radio	Rechargeable Battery Cordless Radio
	MR052  12V max	MR051  10.8V
Run time (hrs)	w/ BL1041B: 30	w/ BL1014: 2.5
Frequency band	FM / AM: 87.5 - 108 MHz / 522 - 1,710 kHz	FM / AM: 87.5 - 108 MHz / 522 - 1,620 kHz
Speaker Size	-	-
Dimensions (L x W x H)*1	w/ BL1016/BL1021B: 169 x 73 x 74 mm (6-5/8 x 2-7/8 x 2-15/16")	169 x 83 x 74 mm (6-5/8 x 3-1/4 x 2-15/16")
Net weight	0.56 - 0.72 kg (1.2 - 1.6 lbs.)	0.49 kg (1.1 lbs.)

The weight may differ depending on the attachment(s), including the battery cartridge.

Product Comparison List





Cordless Radio with Lantern					
	MR010G 40V max  Light tone: 3 tones Brightness: 2 stages	MR009G 40V max  Light tone: 3 tones Brightness: 2 stages	DMR057 18V  Light tone: 3 tones Brightness: 2 stages	DMR056 18V  Light tone: 3 tones Brightness: 2 stages	DMR055 18V  Light tone: 1 tones Brightness: 1 stages
Run time (hrs)	[Radio+Lantern(4 side)] BL4040: 15	[Radio+Lantern(4 side)] BL4040: 14	[Radio+Lantern(4 side)] BL1850B: 12	[Radio+Lantern(4 side)] BL1850B: 12	[Radio+Lantern(4 side)] BL1850B: 12
Frequency band	FM: 87.5 - 108 MHz	FM: 87.5 - 108 MHz / DAB: 174.928 - 239.200 MHz / DAB+: 174.928 - 239.200 MHz	FM: 87.5 - 108 MHz	FM: 87.5 - 108 MHz / DAB: 174.928 - 239.200 MHz / DAB+: 174.928 - 239.200 MHz	FM: 87.5 - 108 MHz / AM: 522 - 1,710 kHz
Illuminance (lx)	4 sides High/Low*2 3 sides High/Low*2	Daylight white: 145/72 or more, Neutral white: 140/70 or more, Warm white: 130/65 or more Daylight white: 130/60 or more, Neutral white: 125/58 or more, Warm white: 115/55 or more			Lantern, Warm white, 4 sides: 130 or more lx
Luminous flux (lm)	4 sides High/Low 3 sides High/Low	Daylight white: 310/155 or more, Neutral white: 300/150 or more, Warm white: 260/130 or more Daylight white: 200/100 or more, Neutral white: 200/100 or more, Warm white: 190/95 or more			Lantern, Warm white, 4 sides: 260 or more lm
Dimensions (L x W x H)	w/ BL4020 / BL4025: 126 x 132 x 288 mm (5 x 5-3/16 x 11-3/8")		w/ BL1830B / BL1840B / BL1850B / BL1860B: 126 x 129 x 289 mm (5 x 5-1/8 x 11-3/8")		
Net weight	1.6 - 2.2 kg (3.5 - 4.9 lbs.)		1.3 - 1.6 kg (2.9 - 3.5 lbs.)		1.2 - 1.6 kg (2.7 - 3.5 lbs.)





*2 Illuminance: measured 0.5m in front of the light source

Cordless Job Site Speaker		
	MR014G 40V max new  Qualcomm [®] aptX [™] HD Qualcomm [®] aptX [™] Bluetooth [®] DC AG	DMR203 18V 12V max  Bluetooth [®] DC AG
Run time (hrs)	[Bluetooth / With the LED decorative line on the front Off] w/ BL4040: 47 / w/ BL1850B: 36	[Bluetooth] w/ BL1850B: 26 / w/ BL1041B: 22
Speaker Size	Woofer: Dia. 140.8 mm / Tweeter: Dia. 40 mm / Passive radiator: Dia. 100.7 mm x2	Woofer: Dia. 101.6 mm / Tweeter: Dia. 36 mm / Passive radiator: Dia. 89 mm
Dimensions (L x W x H)*1	243 x 236 x 313 mm (9-9/16 x 9-1/4 x 12-3/8")	217 x 206 x 285 mm (8-1/2 x 8-1/8 x 11-1/4")
Net weight	3.8 kg (8.4 lbs.)	2.7 - 3.4 kg (6.0 - 7.5 lbs.)

*1 with Handle in upright position

Product Comparison List

	Cordless Fan			
	CF003G 40V max 18V 	CF002G 40V max 	DCF301 18V 	CF001G 40V max 
Continuous Use (min.)	w/ BL4080F at max air speed (w/o oscillation): 230 / w/ BL1860B at max air speed (w/o oscillation): 90	w/ BL4040 Low / Mid / High (w/o oscillation): 1,020 / 640 / 320	w/ BL1860B Low / Mid / High (w/o oscillation): 850 / 430 / 215	w/ BL4040 Low / Mid / High (w/o oscillation): 1,160 / 880 / 660
Max air velocity	96-300 m/min	High / Mid / Low: 240 / 170 / 120 m/min	High / Mid / Low: 240 / 170 / 120 m/min	High / Mid / Low: 190 / 150 / 120 m/min
Air flow	38-120 m ³ /min	High / Mid / Low: 21 / 15 / 10 m ³ /min	High / Mid / Low: 21 / 15 / 10 m ³ /min	High / Mid / Low: 8.2 / 6.5 / 5.2 m ³ /min
Fan diameter	450 mm (17-3/4")	330 mm (13")	330 mm (13")	235 mm (9-1/4")
Automatic oscillation	Left: 30, 45, 60° / Right: 30, 45, 60°	Left: 45° / Right: 45°	Left: 45° / Right: 45°	Left: 45° / Right: 45°
Dimensions (L x W x H)	312 x 633 x 770 mm (12-1/4 x 25 x 30-1/4")	w/ BL4040: 277 x 439 x 602 mm (10-7/8 x 17-1/4 x 23-3/4")	w/ BL1860B: 269 x 439 x 602 mm (10-5/8 x 17-1/4 x 23-3/4")	143 x 333 x 463 mm (5-5/8 x 13 x 18-1/4")
Net weight	7.9 - 10.5 kg (17.4 - 23.1 lbs.)	4.5 - 5.1 kg (9.9 - 11.2 lbs.)	4.1 - 4.5 kg (9.0 - 9.9 lbs.)	2.0 - 3.0 kg (4.4 - 6.6 lbs.)



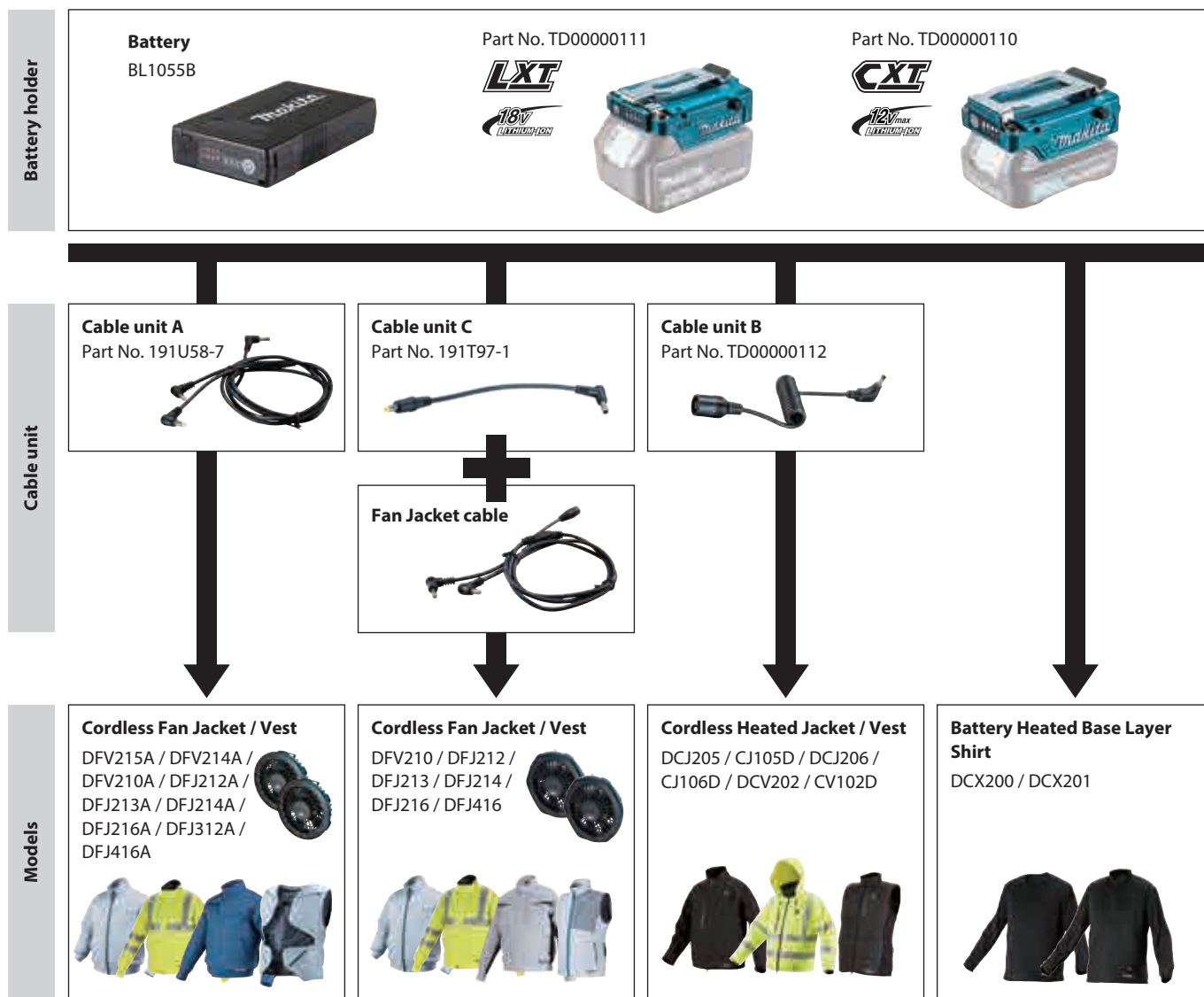

	Cordless Fan			
	DCF203 18V 	DCF102 18V 	CF101D 12V max 	DCF201 18V 
Continuous Use (min.)	w/ BL1860B Low / Mid / High (w/o oscillation): 1,155 / 700 / 430	w/ BL1860B Low / Mid / High: 1,270 / 705 / 575	w/ BL1041 Low / Mid / High: 630 / 380 / 275	w/ BL1830B Low / High: 200 / 100
Max air velocity	High / Mid / Low: 190 / 150 / 120 m/min	High / Mid / Low: 180 / 150 / 120 m/min	High / Mid / Low: 180 / 150 / 120 m/min	High: 120 m/min
Air flow	High / Mid / Low: 8.2 / 6.5 / 5.2 m ³ /min	High / Mid / Low: 4.6 / 3.8 / 3.0 m ³ /min	High / Mid / Low: 4.6 / 3.8 / 3.0 m ³ /min	-
Fan diameter	235 mm (9-1/4")	180 mm (7-1/8")	180 mm (7-1/8")	250 mm (9-7/8")
Automatic oscillation	Left: 45° / Right: 45°	Left: 45° / Right: 45°	Left: 45° / Right: 45°	-
Dimensions (L x W x H)	140 x 333 x 447 mm (5-1/2 x 13 x 17-5/8")	185 x 272 x 284 mm (7-1/4 x 10-3/10 x 11-1/8")	185 x 260 x 284 mm (7-1/4 x 10-1/4 x 11-1/8")	263 x 330 x 523 mm (10-3/8 x 13 x 20-5/8")
Net weight	1.9 - 2.6 kg (4.2 - 5.6 lbs.)	1.3 - 2.0 kg (2.9 - 4.4 lbs.)	1.3 - 1.7 kg (2.8 - 3.8 lbs.)	2.5 - 2.9 kg (5.5 - 6.3 lbs.)

	Cordless Fan
	CF100D 12V max 
Continuous Use (min.)	w/ BL1041 Low / Mid / High: 630 / 380 / 275
Max air velocity	High / Mid / Low: 180 / 150 / 120 m/min
Air flow	High / Mid / Low: 4.6 / 3.8 / 3.0 m ³ /min
Fan diameter	180 mm (7-1/8")
Automatic oscillation	-
Dimensions (L x W x H)	w/ BL1041B: 168 x 260 x 252 mm (6-5/8 x 10-1/4 x 9-7/8")
Net weight	1.2 - 1.4 kg (2.7 - 3.1 lbs.)

Compatibility table







Continuous run time (Cordless Fan Jacket / Vest)

Li-ion Battery	model 1	model 2	model 3	model 4	Li-ion Battery	model 1	model 2	model 3	model 4	Li-ion Battery	model 1	model 2	model 3	model 4
18V   BL1860B (6.0Ah)	68 h	29.5 h	16 h	10 h	12Vmax   BL1041B (4.0Ah)	27.5 h	12 h	6.5 h	4 h	BL1055B (16.75Ah)	40 h	18 h	9.5 h	6 h

*DFV215A / DFV214A / DFV210A / DFJ212A / DFJ213A / DFJ214A / DFJ216A / DFJ312A / DFJ416A only

Charging Time

Li-ion Battery	DC18RC DC18RD* DC18RE**	DC18SF 1 to 2 batteries / 3 to 4 batteries	DC18SD DC18SH* DC18SE (Automotive)	Li-ion Battery	DC10SB DC18RE**	DC10WD		
18V  	BL1860B (6.0Ah)	55 min	130 min / 260 min	130 min	12Vmax  	BL1041B (4.0Ah)	60 min	130 min
	BL1850B (5.0Ah)	45 min	110 min / 220 min	110 min		BL1021B (2.0Ah)	30 min	70 min
	BL1840B (4.0Ah)	36 min	90 min / 180 min	90 min		BL1016 (1.5Ah)	22 min	50 min
	BL1830B (3.0Ah)	22 min	60 min / 120 min	60 min	Li-ion Battery		AC adapter 5V / 2.4A	
	BL1820B (2.0Ah)	24 min	45 min / 90 min	45 min		BL1055B (16.75Ah)		10 h
	BL1815N (1.5Ah)	15 min	30 min / 60 min	30 min				

*DC18RD / DC18SH: Two Port Multi Fast Charger **DC18RE: CXT & LXT Dual port Fast Charger

Cordless Fan Jacket / Cordless Fan Vest

Jacket Size

Vest

photo: DFV210A



Jacket

photo: DFJ216A



DFV215A	S	M	L	XL	2XL	3XL
Length	63/67	65/69	67/71	69/72	71/73	73/74
Shoulder	39/43	41/45	43/47	45/49	47/51	49/53
Chest	106/113	111/118	116/123	121/128	126/133	131/138
Waist	100/107	105/112	110/117	115/122	120/127	125/132

DFV214A	FA (S~L)			FB (XL~3XL)		
Length	49/53			55/57		
Shoulder	39/41			42/44		
Chest	103~122/110~129			112~131/119~138		
Waist	98~117/105~124			107~126/114~133		

DFV210A	S	M	L	XL	2XL	3XL
Length	63/67	65/69	67/71	69/72	71/73	73/74
Shoulder	39/43	41/45	43/47	45/49	47/51	49/53
Chest	106/113	111/118	116/123	121/128	126/133	131/138
Waist	100/107	105/112	110/117	115/122	120/127	125/132

DFJ212A	S	M	L	XL	2XL	3XL
Length	62/66	64/68	66/70	68/71	70/72	72/73
Shoulder	40/44	42/46	44/48	46/50	48/52	50/54
Sleeve	79/87	82/90	85/93	88/95	91/97	92/99
Chest	108/117	113/122	118/127	123/132	128/137	133/142
Waist	102/111	107/116	112/121	117/126	122/131	127/136

DFJ213A	S	M	L	XL	2XL	3XL
Length	61/65	63/67	65/69	67/70	69/71	70/72
Shoulder	43/47	45/49	47/51	49/53	51/55	53/57
Sleeve	58/62	60/64	62/66	64/67	66/68	66/69
Chest	109/117	114/122	119/127	124/132	129/137	134/142
Waist	95~103/ 103~111	100~108/ 108~116	105~113/ 113~121	110~118/ 118~126	115~123/ 123~131	120~128/ 128~136

DFJ214A	S	M	L	XL	2XL	3XL
Length	64/68	66/70	68/72	70/73	72/74	73/75
Shoulder	43/47	45/49	47/51	49/53	51/55	53/57
Sleeve	58/62	60/64	62/66	64/67	66/68	66/69
Chest	109/117	114/122	119/127	124/132	129/137	134/142
Waist	95~103/ 103~111	100~108/ 108~116	105~113/ 113~121	110~118/ 118~126	115~123/ 123~131	120~128/ 128~136

DFJ216A	S	M	L	XL	2XL	3XL
Length	63/67	65/69	67/71	69/72	71/73	72/74
Shoulder	58/62	60/64	62/66	64/67	66/68	66/69
Sleeve	43/47	45/49	47/51	49/53	51/55	53/57
Chest	111/119	116/124	121/129	126/134	131/139	136/144
Waist	81~105/ 89~113	86~110/ 94~118	91~115/ 99~123	96~120/ 104~128	101~125/ 109~133	106~130/ 114~138

DFJ312A	S	M	L	XL	2XL	3XL
Length	62/68	64/70	66/72	68/74	70/76	72/78
Shoulder	50/56.5	52/59	54/61.5	56/64	58/66.5	60/69
Sleeve	52/58	54/60	56/62	58/64	60/66	62/68
Chest	114/126	118/131	122/136	126/141	130/146	134/151
Waist	74~105/ 87~113	78~109/ 92~113	82~113/ 97~113	86~117/ 102~113	90~121/ 109~138	94~125/ 112~143

DFJ416A	S	M	L	XL	2XL	3XL
Length	61/65	63/67	65/69	67/70	69/71	70/72
Shoulder	43/47	45/49	47/51	49/53	51/55	53/57
Sleeve	58/62	60/64	62/66	64/67	66/68	66/69
Chest	111/119	116/124	121/129	126/134	131/139	136/144
Waist	95~105/ 103~113	100~110/ 108~118	105~115/ 113~123	110~120/ 118~128	115~125/ 123~133	120~130/ 128~138

Asian Size/EU&US Size
(cm)

Cordless Heated Jacket / Cordless Heated Vest

Jacket Size

Jacket / Base Layer Shirt

photo: DCJ205



DCJ205/CJ105D	S	M	L	XL	2XL	3XL
Length	68	69	71	75	78	82
Shoulder	50.5	52.5	54.5	55.5	56.5	57.5
Sleeve	63	64.5	66	67	68	69
Chest	108	118	128	138	146	156
Waist	102	112	122	132	140	150

DCX200 DCX201	EU&US Size						
	XS	S	M	L	XL	2XL	3XL
Length	63	65	68	71	74	77	79
Shoulder	44.5	46.5	48.5	51.5	54.5	57.5	60.5
Sleeve	59	60	61	62	63	64	65
Chest	50	53	56	59	63	67	71
Waist	49	52	55	58	62	66	70

Vest

photo: DCV202











DCV202 CV102D	S	M	L	XL	2XL	3XL
Length	72	73	74	75	76	77
Shoulder	47.5	49.5	51.5	53.5	55.5	57.5
Chest	114	120	126	132	138	144
Waist	116	122	128	134	140	146

DCX200 DCX201	Asian Size						
	XS	S	M	L	XL	2XL	3XL
Length	61	63	65	68	71	74	77
Shoulder	42.5	44.5	46.5	48.5	51.5	54.5	57.5
Sleeve	58	59	60	61	62	63	64
Chest	47	50	53	56	59	63	67
Waist	46	49	52	55	58	62	66

(cm)

Product Comparison List



	Cordless Inflator			
	MP001G 40V max 	DMP181 18V 	DMP180 18V 	MP100D 12V max 
Max air pressure	1,110 kPa (161 PSI) [11.1 bar]	1,110 kPa (161 PSI) [11.1 bar]	830 kPa (121 PSI) [8.3 bar]	830 kPa (121 PSI) [8.3 bar]
Air discharge amount	200 kPa: 24 L/min / 700 kPa: 12 L/min / 1,100 kPa: 7 L/min	200 kPa: 22 L/min / 700 kPa: 11 L/min / 1,100 kPa: 7 L/min	200 kPa: 12 L/min / 700 kPa: 8 L/min / 830 kPa: 7 L/min	200 kPa: 10 L/min
Dimensions (L x W x H)	w/ BL4040: 329 x 108 x 231 mm (13 x 4-1/4 x 9-1/8")	w/ BL1830B / BL1840B / BL1850B / BL1860B: 316 x 108 x 231 mm (12-1/2 x 4-1/4 x 9-1/8")	w/ BL1830B / BL1840B / BL1850B / BL1860B: 266 x 80 x 174 mm (10-1/2 x 3-1/8 x 6-7/8")	w/ BL1041B: 255 x 74 x 173 mm (10 x 2-15/16 x 6-13/16")
Net weight	2.9 - 3.5 kg (6.4 - 7.7 lbs.)	2.5 - 2.8 kg (5.5 - 6.2 lbs.)	1.4 - 1.7 kg (3.1 - 3.8 lbs.)	1.2 - 1.3 kg (2.6 - 3.0 lbs.)

	Cordless Cooler & Warmer Box			
	CW004G 40V max 18V x2 	CW002G 40V max 18V x2 	CW003G 40V max 18V x2 	CW001G 40V max 18V x2 
Run time (hrs)	w/ BL1860B x2, -18 / 5 / 60°C: 7.0 / 17.0 / 6.0 hours w/ BL4050F x2, -18 / 5 / 60°C: 12.5 / 30 / 11.5 hours	w/ BL4040 x2, -18 / 5 / 60°C: 8 / 19.5 / 4.5 / w/ BL4050F x2, -18 / 5 / 60°C: 10 / 24.5 / 6	w/ BL4040, -18 / 5 / 60°C: 5.5 / 13.5 / 5.5	w/ BL4050F, -18 / 5 / 60°C: 10 / 28 / 8.5
Capacity	29 L (7.7 gal)	50 L (13.2 gal)	7 L (1.8 gal)	20 L (5.3 gal)
Temperature setting	-18/-15/-10/-5/0/5/10/15/20/25/30/35 / 40/45/50/55/60°C (0/5/15/25/30/40/50/60/70/75/85/95/ 105/115/120/130/140°F)*	-18/-15/-10/-5/0/5/10/30/35/40/45/ 50/55/60°C (0/5/15/25/30/40/50/85/95/105/115/ 120/130/140°F)	-18/-15/-10/-5/0/5/10/30/35/40/45/ 50/55/60°C (0/5/15/25/30/40/50/85/95/105/115/ 120/130/140°F)	-18/-15/-10/-5/0/5/10/30/35/40/45/ 50/55/60°C (0/5/15/25/30/40/50/85/95/105/115/ 120/130/140°F)
Cord length	AC adapter / Cigar socket cable: 2.2 / 2.5 m (7.2 / 8.2 ft)	AC adapter / Cigar socket cable: 2 / 2.5 m (6.5 / 8.2 ft)	AC adapter / Cigar socket cable: 2 / 2.5 m (6.5 / 8.2 ft)	AC adapter / Cigar socket cable: 2 / 2.5 m (6.5 / 8.2 ft)
Dimensions (L x W x H)	676 x 345 x 471 mm (26-5/8 x 13-5/8 x 18-1/2")	867 x 465 x 476 mm (34-1/8 x 18-1/4 x 18-3/4")	456 x 245 x 308 mm (18 x 9-5/8 x 12-1/8")	663 x 341 x 372 mm (26-1/8 x 13-3/8 x 14-5/8")
Net weight	17.5 - 20.9 kg (38.6 - 46.1 lbs.)	25.2 - 29.0 kg (55.6 - 63.9 lbs.)	7.5 - 9.4 kg (16.5 - 20.7 lbs.)	13.5 - 16.1 kg (29.8 - 35.5 lbs.)

*Settable max temperature difference between two rooms: 30°C)



	Cordless Cooler & Warmer Box
	DCW180 18V x2 
Run time (hrs)	w/ BL1860B x2, -18 / 5 / 60°C: 5 / 17 / 4
Capacity	20 L (5.3 gal)
Temperature setting	-18 / -10 / 0 / 5 / 10 / 55 / 60°C (0 / 15 / 30 / 40 / 50 / 130 / 140°F)
Cord length	AC adapter / Cigar socket cable: 2 / 2.5 m (6.5 / 8.2 ft)
Dimensions (L x W x H)	623 x 341 x 371.5 mm (24-1/2 x 13-3/8 x 14-5/8")
Net weight	13.3 - 14.3 kg (29.3 - 32.0 lbs.)

Product Comparison List

	Cordless Kettle	
	KT001G 40V max 	DKT360 18V x2 
Boiling time	8 min (0.8L water from 23 °C)	8 min (0.8L water from 23 °C)
Water tank capacity	800 mL	800 mL
Dimensions (L x W x H)	w/o Battery: 233 x 322 x 307 mm (9-1/8 x 12-5/8 x 12-1/8")	w/o Battery: 233 x 263 x 307 mm (9-1/8 x 10-3/8 x 12-1/8")
Net weight	2.8 - 5.9 kg (6.2 - 13.0 lbs.)	2.7 - 3.4 kg (6.0 - 7.5 lbs.)

	Cordless Coffee Maker
	DCM501 18V 12V max 
Brewing capacity (approx.)	w/ BL1860B: 640 ml / w/ BL1041B: 260 ml
Water tank capacity	240 mL
Compatible cafe pod type	60 mm
Brewing time of 1 cup of coffee	w/ BL1860B: 5 min / w/ BL1041B: 7 min
Dimensions (L x W x H)	w/ BL1830B / BL1840B / BL1850B / BL1860B: 243 x 187 x 218 mm (9-9/16 x 7-3/8 x 8-9/16")
Net weight	1.9 - 2.2 kg (4.1 - 4.8 lbs.)







	Cordless Microwave
	MW001G 40V max 
Capacity	8 L
Output power	High: 500 W / Low: 350 W
Inside dimensions (W x D x H)	255 x 241 x 120 mm (10 x 9-1/2 x 4-3/4")
Dimensions (L x W x H)	w/ BL4040: 372 x 343 x 338 mm (14-5/8 x 13-1/2 x 13-1/4")
weight	9.5 - 12.7 kg (20.9 - 28.0 lbs.)

	Cordless Heated Blanket	
	DCB200 18V 	CB100D 12V max 
Run time (hrs)	w/ BL1860B Low / Mid / High: 35 / 20 / 10	w/ BL1041B Low / Mid / High: 14 / 7.5 / 4
Heat zone	Upper center: 1	Upper center: 1
Dimensions (L x W)	700 x 1,400 mm (27-1/2 x 55")	700 x 1,400 mm (27-1/2 x 55")
Net weight	0.58 kg (1.28 lbs.)	0.58 kg (1.28 lbs.)

PRODUCTS

Speciality tools



-  Double Insulation
-  Variable Speed
-  Anti-restart function
-  Electronic 2-Speed
-  Electronic 3-Speed
-  Built-in Job Light
-  Carrying Case

Speciality tools

Cordless Air Compressor AC001G

40V max



Tank	7.6 L (2 gal)
Max air pressure in tank	0.93 MPa (135 PSI)
Cut-in pressure	0.72 MPa (105 PSI)
No load speed (RPM)	Crank shaft: 2,075
Air flow	at 0.62 MPa (90 PSI): 34 L/min (1.2 SCFM)
Recovery time (from empty to full)	100 sec
Actual nail-driving performance	w/ BL4040: 717 pcs
Dimensions (L x W x H)	w/ European spec tank: 302 x 434 x 382 mm (11-7/8 x 17-1/8 x 15")
Net weight	w/ European spec tank: 11.6-12.8 kg (25.6-28.2 lbs.)



Cordless Grease Gun DGP180

18V



Grease capacity w/ Barrel A	Cartridge / Bulk: 410 / 455 g (14.5 / 16.0 oz)
Max operating pressure	69 MPa (10,000 PSI)
Flow rate	Slow speed mode: 145 mL/min (5.0 oz/min) Auto speed change mode: 290 mL/min (10.0 oz/min)
Hose length	120 cm (47-1/4")
Dimensions (L x W x H)	w/ Barrel A: 411 x 114 x 245 mm (16-1/4 x 4-1/2 x 9-5/8")
Net weight	4.8-6.1 kg (10.6 - 13.4 lbs.)



Cordless Vacuum Pump DVP181

18V x2



Flow rate	113 L/min
Ultimate vacuum	3 Pa
Motor speed	3,200 min ⁻¹
Oil tank capacity	300 mL
Inlet port	5/16" / 3/8"
Continuous use	w/ BL1860B x2: 60min.
Dimensions (L x W x H)	383 x 193 x 210 mm (15-1/8 x 7-5/8 x 8-1/4")
Net weight	8.1 - 8.2 kg (17.9 - 18.1 lbs.)



Cordless Vacuum Pump DVP180

18V



Flow rate	50 L/min
Ultimate vacuum	20 Pa (150 microns)
Motor speed	3,840 min ⁻¹
Oil tank capacity	115 mL
Inlet port	5/16"
Dimensions (L x W x H)	265 x 93 x 175 mm (10-3/8 x 3-5/8 x 6-7/8")
Net weight	3.5 kg



Cordless Caulking Gun DCG180

18V



Max dispersing force	5,000 N (1,100 lbs)
No load speed	0 - 28 mm/sec. (0 - 66 in/min.)
Holder size	300 / 600 / 800 mL
Dimensions (L x W x H)	404 x 108 x 281 mm (15-7/8 x 4-1/4 x 11-1/8")
Net weight	2.1 - 3 kg (4.7 - 6.6 lbs.)



Cordless Caulking Gun CG100D

12V max



Max dispersing force	5,000 N (1,100 lbs)
No load speed	0 - 28 mm/sec. (0 - 66 in/min.)
Holder size	300 / 600 / 800 mL
Dimensions (L x W x H)	404 x 108 x 259 mm (15-7/8 x 4-1/4 x 10-1/4")
Net weight	1.9 - 2.6 kg (4.2 - 5.8 lbs.)



Speciality tools

**Submersible Pump
PF1100**

Continuous rating Input	1,100W
Suction & discharge diameter	4 mm (5/32")
Max pumping capacity	250 L/min (66 gal/min)
Delivery head max	9 m (30 ft)
Submersion depth	5 m (16 ft)
Min. suction level	25 mm (1")
Grain size inlet	5 mm (1/5")
Dimensions (L x W x H)	150 x 150 x 305 mm (6-5/16 x 7-1/8 x 12")
Net weight	6.7 kg (14.8 lbs.)

**Submersible Pump
PF0403**

Continuous rating Input	400W
Suction & discharge diameter	4 mm (5/32")
Max pumping capacity	120 L/min (32 gal/min)
Delivery head max	6.5 m (21 ft)
Submersion depth	5 m (16 ft)
Min. suction level	25 mm (1")
Grain size inlet	5 mm (1/5")
Dimensions (L x W x H)	150 x 150 x 260 mm (5-7/8 x 5-7/8 x 10-1/4")
Net weight	4.4 kg (9.7 lbs.)

**Submersible Pump
PF0800**

Continuous rating Input	800W
Suction & discharge diameter	10 mm (3/8")
Max pumping capacity	220 L/min (58 gal/min)
Delivery head max	9 m (30 ft)
Submersion depth	5 m (16 ft)
Min. suction level	20 mm (4/5")
Grain size inlet	5 mm (1/5")
Dimensions (L x W x H)	160 x 168 x 340 mm (6-5/16 x 6-5/8 x 13-3/8")
Net weight	6.1 kg (13.5 lbs.)

**Submersible Pump
PF0300**

Continuous rating Input	300W
Suction & discharge diameter	8 mm (5/16")
Max pumping capacity	140 L/min (37 gal/min)
Delivery head max	7 m (23 ft)
Submersion depth	5 m (16 ft)
Min. suction level	20 mm (4/5")
Grain size inlet	5 mm (1/5")
Dimensions (L x W x H)	160 x 168 x 305 mm (6-5/16 x 6-5/8 x 12")
Net weight	4.2 kg (9.3 lbs.)

**Submersible Pump
PF1110**

Continuous rating Input	1,100W
Suction & discharge diameter	40 mm (1-9/16")
Max pumping capacity	250 L/min (66 gal/min)
Delivery head max	10 m (33 ft)
Submersion depth	5 m (16 ft)
Min. suction level	50 mm (2")
Grain size inlet	35 mm (1-3/8")
Dimensions (L x W x H)	160 x 185 x 355 mm (6-5/16 x 7-1/4 x 14")
Net weight	7 kg (15.4 lbs.)

**Submersible Pump
PF1010**

Continuous rating Input	1,100W
Suction & discharge diameter	30 mm (1-3/16")
Max pumping capacity	240 L/min (63 gal/min)
Delivery head max	10 m (33 ft)
Submersion depth	5 m (16 ft)
Min. suction level	40 mm (1-4/7")
Grain size inlet	35 mm (1-3/8")
Dimensions (L x W x H)	160 x 168 x 380 mm (6-5/16 x 6-5/8 x 15")
Net weight	6.6 kg (14.6 lbs.)

**Submersible Pump
PF0610**

Continuous rating Input	550W
Suction & discharge diameter	40 mm (1-9/16")
Max pumping capacity	180 L/min (48 gal/min)
Delivery head max	7 m (23 ft)
Submersion depth	5 m (16 ft)
Min. suction level	50 mm (2")
Grain size inlet	35 mm (1-3/8")
Dimensions (L x W x H)	160 x 185 x 335 mm (6-5/16 x 7-1/4 x 13-1/4")
Net weight	5.5 kg (12.3 lbs.)

**Submersible Pump
PF0410**

Continuous rating Input	400W
Suction & discharge diameter	25 mm (1")
Max pumping capacity	140 L/min (37 gal/min)
Delivery head max	5 m (16 ft)
Submersion depth	5 m (16 ft)
Min. suction level	40 mm (1-4/7")
Grain size inlet	35 mm (1-3/8")
Dimensions (L x W x H)	160 x 168 x 345 mm (6-5/16 x 6-5/8 x 13-5/8")
Net weight	4.3 kg (9.5 lbs.)

Cordless Heat Gun DHG181

18V



Air temperature	Dial 1: Ambient temperature Dial 2: 150°C / Dial 3: 250°C Dial 4: 350°C / Dial 5: 450°C Dial 6: 550°C
Air flow	Stage 1: 120 L/min Stage 2: 200 L/min
Continuous use	w/ BL1860B, Stage 1: 30 min. w/ BL1860B, Stage 2: 21 min.
Nozzle joint portion	34.5 mm (1-3/8")
Dimensions (L x W x H)	w/ BL1830B / BL1840B / BL1850B / BL1860B: 173 x 79 x 255 mm (6-3/16 x 3-1/8 x 10")
Net weight	1.0 - 1.4 kg (2.2 - 3.1 lbs.)

LXT



Cordless Heat Gun DHG180

18V



Air temperature	550°C
Air flow	200 L/min
Continuous use	w/ BL1860B: 21 min.
Nozzle joint portion	34.5 mm (1-3/8")
Dimensions (L x W x H)	w/ BL1830B / BL1840B / BL1850B / BL1860B: 168 x 79 x 251 mm (6-5/8 x 3-1/8 x 9-7/8")
Net weight	1.0 - 1.3 kg (2.2 - 2.9 lbs.)

LXT



Heat Gun HG6530V



Continuous rating Input	2,000W
Air temperature	50 - 650°C
Air flow	Stage 1: 500 L/min Stage 2: 280 L/min Stage 3: 550 L/min
Dimensions (L x W x H)	257 x 85 x 206 mm (10-1/8 x 3-3/8 x 8-1/8")
Net weight	0.72 kg (1.6 lbs.)



Heat Gun HG6531C



Continuous rating Input	2,000W
Air temperature	50 - 650°C
Air flow	200 - 550 L/min
Dimensions (L x W x H)	257 x 85 x 206 mm (10-1/8 x 3-3/8 x 8-1/8")
Net weight	0.71 kg (1.6 lbs.)



Heat Gun HG6030



Continuous rating Input	1,800W
Air temperature	Stage 1: 50 °C Stage 2: 300 °C Stage 3: 600 °C
Air flow	Stage 1: 250 L/min Stage 2: 250 L/min Stage 3: 500 L/min
Dimensions (L x W x H)	233 x 80 x 208 mm (9-1/8 x 3-1/8 x 8-3/16")
Net weight	0.57 kg (1.3 lbs.)



Heat Gun HG6031V



Continuous rating Input	1,800W
Air temperature	Stage 1: 50 - 400 °C Stage 2: 100 - 600 °C
Air flow	Stage 1: 250 L/min Stage 2: 500 L/min
Dimensions (L x W x H)	257 x 85 x 206 mm (10-1/8 x 3-3/8 x 8-1/8")
Net weight	0.67 kg (1.5 lbs.)



Heat Gun HG5030



Continuous rating Input	1,600W
Air temperature	Stage 1: 350 °C Stage 2: 500 °C
Air flow	Stage 1: 300 L/min Stage 2: 500 L/min
Dimensions (L x W x H)	233 x 80 x 208 mm (9-1/8 x 3-1/8 x 8-3/16")
Net weight	0.56 kg (1.2 lbs.)



PRODUCTS

Accessories



Accessory

Battery Adapter ADP12

40V max



Communication connector designed to enable communication between XGT tool/battery and mobile device/PC

Dimensions (L x W x H) 98 x 85 x 55 mm
(3-7/8 x 3-3/8 x 2-3/16")
Net weight 0.17 kg (0.38 lbs.)



Battery Adapter ADP13

40V max



Communication connector designed to enable communication between XGT tool/battery and mobile device/PC

Dimensions (L x W x H) 98 x 85 x 55 mm
(3-7/8 x 3-3/8 x 2-3/16")
Net weight 0.17 kg (0.38 lbs.)



Adapter for USB ADP001G

40V max



Charges mobile devices e.g. smartphones, tablets and more, and developed as XGT version of ADP05

Dimensions (L x W x H) w/ BL4020 / BL4025:
119 x 79 x 88 mm
(4-11/16 x 3-1/8 x 3-1/2")
w/ BL4040:
133 x 83 x 94 mm
(5-1/4 x 3-1/4 x 3-11/16")
w/ BL4050F:
153 x 79 x 114 mm
(6 x 3-1/8 x 4-1/2")
Net weight 0.8 - 1.4 kg (1.8 - 3.1 lbs.)



AA Battery Pack ADP09



AA battery pack designed to supply power to the machines (compatible with only some models such as green multi line lasers) powered by 12Vmax CXT Li-ion battery



Adapter for USB ADP05

18V



Charges mobile devices e.g. smartphones, tablets and more

Net weight 0.11 kg (0.24 lbs.)



Adapter for USB ADP06

12V max



Charges mobile devices e.g. smartphones, tablets and more

Net weight 0.07 kg (0.15 lbs.)



Adapter for USB ADP08

12V max



Charges mobile devices e.g. smartphones, tablets and more

Net weight 0.06 kg (0.13 lbs.)



Accessory Index

<p>p.205</p> <p>Screwing/ Drilling</p>	<p>Drill chuck assembly for impact driver</p> 	<p>Angle attachment</p> 	<p>Straight head</p> 	<p>Autofeed attachment</p> 	<p>Locator</p> 	<p>Drill chuck</p> 	
<p>p.206</p> <p>Hammer drilling/ chiselling</p>	<p>Drill chuck assembly</p> 	<p>Dust extraction system set</p> 	<p>Filter</p> 	<p>Hammer carrier</p> 	<p>Grease vessel</p> 		
<p>p.208</p> <p>Grinding/ Sanding/ Polishing</p>	<p>Rubber pad</p> 	<p>Wheel guard</p> 	<p>Inner flange & Lock nut</p> 	<p>Grip</p> 	<p>Collet corn/ Collet nut</p> 	<p>Punch plate</p> 	
<p>p.212</p> <p>Cutting</p>	<p>Tilt base</p> 	<p>Cover set</p> 	<p>Cutting wax</p> 	<p>Threaded rod cutter blade</p> 	<p>Punch/ Die</p> 		
<p>p.214</p> <p>Sawing</p>	<p>Crown molding stopper</p> 	<p>Extension table</p> 	<p>Stand</p> 	<p>Guide rail</p> 	<p>Guide Rail Adaptor</p> 		
<p>p.217</p> <p>Milling/ Planing</p>	<p>Collet corn/ Collet nut</p> 	<p>Straight guide assembly</p> 	<p>Trimmer base</p> 	<p>Templet guide</p> 	<p>Drywall guide bit</p> 		
<p>p.219</p> <p>Fastening/ Fixing</p>	<p>Nails & Staples</p> 	<p>Coil tape collated screws</p> 	<p>Flat Tape Collated Screws</p> 	<p>Rivet gun maintenance kit</p> 	<p>Tie wire set</p> 		
<p>p.224</p> <p>Cleaning</p>	<p>Vacuum Cleaner System charts for Dust Collecting</p> 	<p>Vacuum Cleaner System charts for Cleaning</p> 	<p>Filter & Dust bag</p> 	<p>Cordless Cleaner System charts</p> 	<p>Selectable filters</p> 	<p>Hose, Front cuffs & Joint</p> 	<p>Dust Blower accessories</p> 
<p>p.242</p> <p>OPE</p>	<p>Brushcutter blades</p> 	<p>Nylon cutting head</p> 	<p>Chain blade</p>  <p>Guide Bar</p> 	<p>Shear blade</p> 	<p>Wheelbarrow attachment</p> 	<p>Robotic mower accessories</p> 	
<p>p.261</p> <p>Others</p>	<p>Worklight accessories</p> 	<p>Grease Gun accessories</p> 	<p>Heat Gun accessories</p> 	<p>Hook</p> 	<p>Battery adapter & battery converter</p> 		

Drill chuck assembly for impact driver

Still photo	Name	Related models	Type	Part No.
	Drill chuck S10 & key set	TD0100, TD0101, TD0101F	48-NZ	191880-6
	Keyless drill chuck set	TD0100	44-MZ	192077-0
		DTP141, TD0100, TD0101, TD0101F, TD127D	48-NZ	192121-3
		DTP141, TD0100	44-MZ	194250-8
		DTP141, TD0100, TD0101, TD0101F	44-MZ	194251-6
	Drill chuck set	DF030D, TD0100, TD0101, TD0101F, TD090D, TD091D, TD111D	48-NZ	198913-8

Angle attachment

Still photo	Name	Related models	No load speed high(rpm)	No load speed low(rpm)	Part No.
	Angle attachment set	DA4000LR	900	400	193316-1

Extension attachment

Still photo	Name	Related models	Part No.
	Extension attachment set	DA4000LR	193317-9

Head for driver

Still photo	Name	Related models	Type	Part No.
	Straight attachment	DTL061, DTL063, TL064D, TL065D	NZ	192440-7
	Straight attachment set		For E-form bit MZ	192486-3

Ratchet head adapter

Still photo	Name	Related models	Type	Part No.
	Socket adapter 9.5 set	DWR180, WR100D	Hex. 13mm - SQ-Drive	191A50-3
	Socket adapter 6.35 set			191A51-1
	Ratchet attachment set	DTL061, DTL063, TL064D, TL065D	Hex. 21mm	192439-2

Adjustable locator for impact driver

Still photo	Name	Related models	Part No.
	Stopper set	DTD152, DTD153, DTD154, DTD157, LM002J, TD0100, TD0101, TD0101F, TD111D	194281-7
		6952, DTD152, DTD153, DTD154, DTD157	194633-2

Autofeed attachment set



Name	Related models	Part No.
Autofeed attachment set	DFS250, DFS452, FS2200, FS2300, FS4000, FS4200, FS4300, FS6200, FS6300, FS6300R	191L23-2 191L24-0
	DFS250, DFS452, FS2200, FS4000, FS4200, FS6200, FS6300	191L25-8

Casing for auto feed screwdriver



Name	Related models	Part No.
Casing 41 set	DFR452	1915G8-5
Casing 55 set	DFR551	1915G9-3
	DFR550	191B45-2

Bit for autofeed attachment set

*Use with Autofeed attachment set



Name	Related models	Part No.
Phillips bit 2-137 set	DFR452, DFR453	191V01-2
Phillips bit 2-155 set	DFR551, DFR552	191V02-0
Square bit 2-137 set	DFR452	191V03-8
Square bit 2-155 set	DFR551	191V04-6
Pozidrive bit 2-137 set	DFR452	191V05-4
Pozidrive bit 2-155 set	DFR551	191V06-2
Phillips bit 2-130 set	DFS452	199155-7
Square bit 2-130 set	DFS250, DFS452, FS2200, FS2300, FS4000, FS4200, FS4300, FS6200, FS6300, FS6300R	*199156-5
Bit 2-130 set	DFS250, DFS452, FS2200, FS4000, FS4200, FS6200, FS6300	*199409-2
Square bit 2-130 set		*199410-7

Shear wrench sleeve

For Model 6922NB DWT310, WT001G

*Type F (for HEXA TECH (GFD France))

** for Chinese market



Bolt Size	Outer sleeve			Inner sleeve	
	Hex size	L (mm)	Part No.	L (mm)	Part No.
M16	27	35	764362-7	36	764416-0 *764421-7
		81	764367-7	82	764356-2
		100	764406-3	100	764400-5
		200	764407-1	200	764401-3
M20	32	37	764361-9 **196276-6	38	764417-8 *764422-5
		764361-9			
		83	764363-5	84	764357-0
		100	764408-9	100	764402-1
M22, 7/8"	36 1-7/16"	200	764409-7	200	764403-9
		39	153909-6	39	764418-6 *764423-3
		85	764364-3	85	764352-0
		100	764410-2	100	764404-7
3/4"	1-1/4"	170	764365-1	170	764354-6
		200	764411-0	200	764405-5
		37	764361-9	38	764419-4
		83	764363-5	84	764353-8
5/8"	1-1/16"	168	764366-9	169	764355-4
		35	764362-7	36	764420-9

For Model 6924N

Bolt Size	Outer sleeve			Inner sleeve	
	Hex size	L (mm)	Part No.	L (mm)	Part No.
M22	36	49	194033-6	48	194310-6
M24	41		194034-4	49	194311-4
7/8"	1-7/16"		194092-0	48	194310-6
1"	1-5/8"		194034-4	49	194312-2

Screwing/ Drilling, Hammer drilling/ chiselling



SDS-MAX Drill bit remover set

Still photo	Name	Related models	Connection type	Connection size mm (inch)	Part No.
	Drill bit remover set	6905H, DTW450, TW0350	Square drive	12.7 (1/2)	195870-1 195871-9



Bit adapter for screwing, Drilling

Still photo	Name	Related models	Part No.
	Bit adapter set [1/2" inch Driver to E-form (MZ)]	6953, DTW251, TW0200	191B20-8

Extension handle

Still photo	Name	Related models	Part No.
	Extension handle set	DTW1001, DTW1002, DTW1004, DTW700, DTW701, DTW800, TW001G, TW002G, TW003G, TW007G, TW008G	191G67-2
		DFR550, DFR750	194500-1

Anti kick back head

Still photo	Name	Related models	Type	Part No.
	Anti kick back head M set	DFT043F, DFT083F, DFT125F	MZ	195231-5
	Anti kick back head N set	DFT043F, DFT083F, DFT125F	NZ	195232-3
	Anti kick back head set	DFL651F	-	197045-8

Torque tracer accessory





Name	Related models	Part No.
Receiver set RCV02	DFL201R, DFL301R, DFL402R, DFT041R, DFT082R, DFT124R	194444-5
		194480-1
		195392-1
	DFL201R, DFL301R	196962-9

Side grip for drill and Angle drill

Still photo	Name	Related models	Part No.
	Grip 36 complete	DS4011, DS4012, DS5000	152492-0
	Grip complete	DA4000LR, DS4011, DS4012, DS5000	152892-4
	Grip assembly set	DDF489	1912A3-5
		DHP489	1912A4-3
	Side handle set	DP4020, DP4021	1914C4-9
	Handle set	DDG461, DG002G	191P11-3
	Grip set	DA001G, DA002G	191R81-4

Drill chuck assembly

Still photo	Name	Related models	Connection type	Part No.
	Keyless drill chuck assembly	HR2230, HR2300, HR2600	SDS-PLUS	122823-7
	Drill chuck set	HR2230, HR2475, HR2631F, HR2652, HR2670, HR2810	SDS-PLUS	194041-7

Quick change drill chuck set

Still photo	Name	Type	Related models	Part No.
	Tool holder set	SDS-PULS tool holder	HR009G, HR3012FC	191F47-2
			DHR281, DHR283, HR002G, HR004G	199138-7
			HR3210FCT	194578-4
	Drill chuck set	Keyless drill chuck	DHR281, DHR283, HR002G, HR004G	199139-5
			HR009G, HR2670FT, HR3012FC	191F46-4
			DHR243, DHR264, HR2320T, HR2630T, HR2631F, HR2631FT, HR2653T, HR2810T, HR2811FT	194079-2
			HR3210FCT	194568-7

Spacer set

Still photo	Name	Related models	Description	Part No.
	Spacer set	HR008G, HR3001C, HR3011FC	Attachment required when using	191L91-5

Dust extraction system set



Name	Related models
DX06	DHR242
DX07	DHR243
DX08	DHR280, DHR282
DX09	DHR281, DHR283
DX10	HR008G, HR3011FC
DX11	HR009G, HR3012FC
DX12	HR001G, HR003G
DX14	HR002G, HR004G
DX15	HR007G
DX16	HR010G, DHR183

Dust case for dust extraction system

Still photo	Name	System No.	Part No.
-	Dust case set	DX06, DX07, DX08, DX09, DX12, DX14	199555-1
		DX10, DX11	191F49-8
		DX15	199586-0
		DX16	1911P5-0

Filter for dust extraction system

Still photo	Name	System No.	Part No.
	Filter set	DX06, DX07, DX08, DX09, DX10, DX11, DX12, DX14, DX15	199557-7
		DX05, DX16	199596-7

Side grip, handle for hammer drills

Still photo	Name	Related models	Part No.
	Grip assembly set	DDF484, DF002G, DHP484, HP002G	191E41-8
	Grip base set	HR1841F	194581-5
		HR2230	194583-1
	Side handle 73 set	HR005G, HR4003C, HR4013C	196792-8

Hammer carrier



Name	Related models	Part No.
Hammer carrier	HM004G	JM0000674

Hammer bit grease and Machine grease

Still photo	Name	Note	Related models	Part No.
	Grease vessel set	Hammer bit grease 100ml	All Rotary Hammer, Demolition Hammer and Electric Breaker	194683-7
	Grease vessel set (for russia)			198993-4
	Grease set	80ml	HR140D, HR166D, HR4002, HR4501C	1914D0-4
		-	DHR171, HR140D, HR166D, HR3200C, HR3210C, HR3210FCT, HR3540C, HR3541FC, HR4002, HR4501C, HR4510C, HR4511C	1914C6-5
		-	HM0810, HM0810T, HM1201	1914C5-7
	Oil vessel set	100ml	HM1306	1914A4-5
	Grease vessel set	Machine grease 30g	HK0500, HR166D, HR3200C, HR3210C, HR3210FCT, HR3540C, HR3541FC	197793-9
	Oil vessel set	Machine grease 26g	HR001G, HR007G, HR010G, HR140D, HR166D, HR2300, HR2320T, HR2475, HR2600, HR2601, HR2630T, HR2631F, HR2631FT, HR2641, HR2652, HR2653, HR2653T	195127-0
	Oil vessel set (for russia)		DHR202, DHR241, DHR242, DHR263, DHR264, HR2230, HR2300, HR2475, HR2600, HR2631F, HR2631FT, HR2641, HR2652, HR2653	198176-6

Grinding/ Sanding/ Polishing

Inner flange & Lock nut

(For depressed center wheel, diamond wheel and Cutting wheel)

*Ezynut (Toolless Lock nut) 20 pcs. set :195462-6

* Do not use Ezynut with Makita Super Flange or Makita angle grinder with "F" on the end of the model No. Those flanges are so thick that the entire threaded cannot be retained by the spindle.

Applicable models: Makita 180mm/230mm angle grinders, and following models equipped with M14 spindle

Wheel size	Brake	Models	Spindle thread	for Depressed center wheel (Type:27, 28, 29, 42)			for Abrasive cut-off wheel (Type:41)				for Diamond cut-off wheel			Lock nut		Ezynut (Toolless Lock nut)				
				Size	Arbor size (mm)	Inner flange Part No.	Size	Arbor size (mm)	Inner flange Part No.	Outer flange Part No.	Size	Arbor size (mm)	Inner flange Part No.	Size	Part No.		Part No.			
																Part No.		Part No.	Part No.	
100mm	Without Brake System	-	M10x1.5	29	16	224491-3	29	16	224491-3	-	29	16/20	224491-3	10-29	224610-1	-				
			M10x1.25	30	16	224270-9	30	16	224270-9	-	30	16/20	224270-9	10-30	224578-1	-				
			M10x1.25	35	16 (5/8")	224377-1	35	16 (5/8")	224377-1	-	35	16 (5/8")	224377-1	10-35	194608-1	-				
			M10x1.5	29	16	224491-3	29	16	224491-3	-	29	16/20	224491-3	10-29	224610-1	-				
	With Brake System		M10x1.5	30	15/16	224407-8	30	15/16	224407-8	-	30	15/16	224407-8	10-29	224610-1	-				
			M10x1.5	30	29B	16	224492-1	30	29B	16	224492-1	-	30	29B	16/20	224492-1	10-29	224610-1	-	
			M10x1.5	29B	16	224492-1	29B	16	224492-1	-	29B	16/20	224492-1	10-29	224610-1	-				
			M10x1.5	30B	15	224452-3	30B	15	224452-3	-	30B	15/20	224492-1	10-30	224558-7	-				
115mm/125mm	Without Brake System	-	M14x2 (DIN)	45	-	224490-5	45	22.23 (7/8")	224490-5	-	45	22.23 (7/8")	224490-5	14-45	224485-8 224554-5	*195354-9				
				47	-	192227-7	47	22.23 (7/8")	192227-7	-	47	22.23 (7/8")	192227-7	14-45	224485-8 224554-5	-				
				45	22.23 (7/8")	191W78-3	45	22.23 (7/8")	191W78-3	-	45	22.23 (7/8")	191W78-3	5/8-45	193465-4	-				
				45	-	224490-5	45	22.23 (7/8")	224490-5	-	42	22.23 (7/8")	224490-5	14-45	224485-8 224554-5	*195354-9				
				42	-	224415-9	42	22.23 (7/8")	224415-9	-	42	22.23 (7/8")	224415-9	14-45	224485-8 224554-5	*195354-9				
	With Brake System		M14x2 (DIN)	42B	22.23 (7/8")	224447-6	42B	22.23 (7/8")	224447-6	-	42B	22.23 (7/8")	224447-6	14-45	224485-8 224554-5	*195354-9				
			5/8"-11 UNC	45B	22.23 (7/8")	224448-4	45	22.23 (7/8")	224448-4	-	45B	22.23 (7/8")	224448-4	5/8-45	193465-4	-				
			Without Brake System	M14x2 (DIN)	42	22.23 (7/8")	224415-9	42	22.23 (7/8")	224415-9	-	42	22.23 (7/8")	224415-9	14-45	224485-8 224554-5	*195354-9			
				Super Flange	M14x2 (DIN)	47	22.23 (7/8")	192227-7	47	22.23 (7/8")	192227-7	-	47	22.23 (7/8")	192227-7	14-45	224554-5	-		
				5/8"-11 UNC	82	22.23 (7/8")	224602-0	45	22.23 (7/8")	191W78-3	-	45	22.23 (7/8")	191W78-3	5/8-45	193465-4	-			
150mm	Without Brake System	-	M14x2 (DIN)	42	22.23 (7/8")	224415-9	42	22.23 (7/8")	224415-9	-	42	22.23 (7/8")	224415-9	14-45	224485-8 224554-5	*195354-9				
				47	22.23 (7/8")	192227-7	47	22.23 (7/8")	192227-7	-	47	22.23 (7/8")	192227-7	14-45	224554-5	-				
				5/8"-11 UNC	82	22.23 (7/8")	224602-0	45	22.23 (7/8")	191W78-3	-	45	22.23 (7/8")	191W78-3	5/8-45	193465-4	-			
				5/8"-11 UNC	45	22.23 (7/8")	191W78-3	45	22.23 (7/8")	191W78-3	-	45	22.23 (7/8")	191W78-3	5/8-45	193465-4	-			
				M14x2 (DIN)	42	22.23 (7/8")	224490-5	42	22.23 (7/8")	224490-5	-	42	22.23 (7/8")	224490-5	14-45	224485-8 224554-5	*195354-9			
	With Brake System		M14x2 (DIN)	42	22.23 (7/8")	224415-9	42	22.23 (7/8")	224415-9	-	42	22.23 (7/8")	224415-9	14-45	224485-8 224554-5	*195354-9				
			45	22.23 (7/8")	224490-5	45	22.23 (7/8")	224490-5	-	45	22.23 (7/8")	224490-5	14-45	224485-8 224554-5	*195354-9					
			Without Brake System	M14x2 (DIN)	42	22.23 (7/8")	224415-9	42	22.23 (7/8")	224415-9	-	42	22.23 (7/8")	224415-9	14-45-8.5 14-45-8.5 14-45-11	224485-8 224554-5 224543-0	*195354-9			
				45	22.23 (7/8")	224490-5	45	22.23 (7/8")	224490-5	-	45	22.23 (7/8")	224490-5	14-45-8.5 14-45-8.5 14-45-11	224485-8 224554-5 224543-0	*195354-9				
				Super Flange	M14x2 (DIN)	47	22.23 (7/8")	192227-7	47	22.23 (7/8")	192227-7	-	47	22.23 (7/8")	192227-7	14-45-8.5 14-45-8.5 14-45-11	224485-8 224554-5 224543-0	-		
180mm/230mm	Without Brake System	-	M14x2 (DIN)	42	22.23 (7/8")	224415-9	42	22.23 (7/8")	224415-9	-	42	22.23 (7/8")	224415-9	14-45-8.5 14-45-8.5 14-45-11	224485-8 224554-5 224543-0	*195354-9				
				45	22.23 (7/8")	224490-5	45	22.23 (7/8")	224490-5	-	45	22.23 (7/8")	224490-5	14-45-8.5 14-45-8.5 14-45-11	224485-8 224554-5 224543-0	*195354-9				
				Super Flange	M14x2 (DIN)	47	22.23 (7/8")	192227-7	47	22.23 (7/8")	192227-7	-	47	22.23 (7/8")	192227-7	14-45-8.5 14-45-8.5 14-45-11	224485-8 224554-5 224543-0	-		
				5/8"-11 UNC	89	22.23 (7/8")	224317-9	5/8 78	22.23 (7/8")	224255-5	224256-3	45	22.23 (7/8")	191W78-3	5/8-45	193465-4 224486-6	-			
				5/8"-11 UNC	45	22.23 (7/8")	191W78-3	45	22.23 (7/8")	191W78-3	-	45	22.23 (7/8")	191W78-3	5/8-45	193465-4 224486-6	-			
	With Brake System		GA7070, GA7071, GA9070, GA9071	-	M14x2 (DIN)	42	22.23 (7/8")	224415-9	14	22.23 (7/8")	224257-1	224256-3	42	22.23 (7/8")	224415-9	14-45-8.5 14-45-8.5 14-45-11	224485-8 224554-5 224543-0	-		
						45	22.23 (7/8")	224490-5	78	22.23 (7/8")	224490-5	-	45	22.23 (7/8")	224490-5	14-45-8.5 14-45-8.5 14-45-11	224485-8 224554-5 224543-0	*195354-9		
						M14x2 (DIN)	45	22.23 (7/8")	224490-5	45	22.23 (7/8")	224490-5	-	45	22.23 (7/8")	224490-5	14-45-8.5 14-45-8.5 14-45-11	224485-8 224554-5 224543-0	*195354-9	
						M16	40	22	224029-4	40	22	224029-4	-	40	22	224029-4	16-40	224521-0	-	
						Super Flange	M16	47	22	122482-7	47	22	122482-7	-	47	22	122482-7	16-45	224487-4 224546-4	-
For Dust collection wheel guard type D (Super Flange)	-	-	M14x2 (DIN)	-	-	-	-	-	-	-	47	22.23 (7/8")	192227-7	14-45-8.5	224485-8 224554-5	-				
				5/8"-11 UNC	-	-	-	-	-	-	47	22.23 (7/8")	126601-7	5/8-45	193465-4 224486-6	-				
				M16x2	-	-	-	-	-	-	-	47	22	192431-8	16-45	224487-4 224546-4	-			
				With Brake System	GA7070, GA7071, GA9070, GA9071	-	M14x2 (DIN)	42B	22.23 (7/8")	224447-6	42B	22.23 (7/8")	224447-6	-	42B	22.23 (7/8")	224447-6	14-45-8.5	224485-8 224554-5	*195354-9
								89	22.23 (7/8")	224500-8	5/8 78	22.23 (7/8")	224589-6	224305-6	45B	22.23 (7/8")	224448-4	5/8-45	193465-4 224486-6	-
With Brake System	GA7070, GA7071, GA9070, GA9071	-	M14x2 (DIN)	45B	22.23 (7/8")	224448-4	45B	22.23 (7/8")	224448-4	-	45B	22.23 (7/8")	224448-4	5/8-45	193465-4 224486-6	-				
				42B	22.23 (7/8")	224447-6	14 78	22.23 (7/8")	224499-7	224256-3	42B	22.23 (7/8")	224447-6	14-45-8.5	224485-8 224554-5	*195354-9				
With Brake System	GA7070, GA7071, GA9070, GA9071 + Dust collection wheel/guard type D (Super Flange)	-	M14x2 (DIN)	-	-	-	-	-	-	-	45CC	22.23 (7/8")	198678-2	14-45-8.5	224485-8 224554-5	-				
				5/8"-11 UNC	-	-	-	-	-	-	-	45CA	22.23 (7/8")	198676-6	5/8-45	193465-4 224486-6	-			

Rubber pad

Still photo	Name	Related models	Outer diameter mm (inch)	Part No.
	Rubber pad set	GA7060, GA7061, GA7061R, GA7070, GA7080, GA7081, GA7082, GA9050, GA9060, GA9060R, GA9061R, GA9070, GA9080, GA9081, GA9082	170	192978-2

lock nut

Still photo	Name	Related models	Part No.
	Lock nut 5/8-48 set	9237C, 9566CV, 9566PC, 9566PCV, GA4552, GA4552R, GA4590, GA4591, GA4595, GA5010, GA5011, GA5020, GA5052, GA5052R, GA5090, GA5091, GA5092, GA5093, GA5095, GA6010, GA6020, GA7020, GA7031, GA7040S, GA7050, GA7060, GA7061, GA7061R, GA9031, GA9040S, GA9050, GA9060, GA9060R, GA9061R, PV001G	193048-0

Accessory kit

Still photo	Name	Related models	Part No.
	Sander kit	9237C	193958-1



Hook & loop pad for Polisher, sander

Still photo	Name	Related models	Outer diameter mm (inch)	Part No.
	Triangle plate complete set		-	191Y22-2
	Rectangle plate complete set	DBO480, DBO481, DBO482, DBO484	-	191Y23-0
	Pad complete set		-	191Y24-8
	Pad 123 set	BO5030, BO5031, BO5040, BO5041, DBO180	123 (4-7/8)	197468-0
	Pad 100 set	DPO500, DPO600, PO5000C, PO6000C	100 (4)	197925-8
	Pad 150 set	DPO500	150 (6)	197928-2
	Pad 220 set	DSL801	220 (8-5/8)	199938-5
	Pad 210 set	DSL801	210 (8-1/4)	199939-3
				199940-8





Pad complete for sander

Still photo	Name	Related models	Part No.
	Square pad set	BO005CG, BO006CG	1914H9-4
	Triangle pad set		1914J0-6
	Pad 125 set	BO001CG, BO003CG	1914J2-2
	Pad 150 set	BO002CG, BO004CG	1914J3-0
	Pad complete set	DBO480, DBO481, DBO482, DBO484	191Y25-6
	Pad set	BO4900V	193522-8
	Pad complete set	BO3710, BO3711, DBO380, DBO381	194929-1
			194930-6
			197464-8



Felt pad for polisher, sander

Still photo	Name	Related models	Outer diameter mm (inch)	Part No.
	Felt pad 150 set	BO6030, BO6050, DPO500, DPO600	150 (5-7/8)	193288-0
	Felt pad set	BO5031, BO5041, DBO180, DPO500, DPO600, PO5000C, PO6000C	125 (4-7/8)	196152-4

Sponge pad for polisher, sander

Still photo	Name	Related models	Outer diameter mm (inch)	Part No.
	Sponge pad 80 set	DPV300, PV301D	80 (3-1/8)	191N90-9
				191N91-7
	Sponge pad 190 set	PV7001C	190 (7-1/2)	193470-1
	Sponge pad 150 set	DPO600	150 (5-7/8)	197894-3

Wool pad for polisher, sander

Still photo	Name	Related models	Outer diameter mm (inch)	Part No.
	Wool pad 80 set	DPV300, PV301D	80 (3-1/8)	191N92-5
	Wool pad 180 set	9237CB, PV001G	180 (7-1/8)	191D53-5
		9237C, 9237CB, PV001G, PV7000C		192629-7

Grinding/ Sanding/ Polishing

Wheel guard

Still photo	Name	Related models	Part No.
	Wheel cover 115CL set	GA4590, GA4591, GA4595, GA5093, GA5095	1910X7-6
	Wheel cover 125CL set	GA5090, GA5091, GA5092, GA5093, GA5095	1910X8-4
	Wheel cover 115C set	GA004G, GA007G, GA012G, GA015G, GA022G, GA025G, GA028G, GA031G, GA049G, GA4590, GA4591, GA4592, GA4593, GA4594, GA4595	1910X9-2
	Wheel cover 125C set	GA005G, GA008G, GA013G, GA016G, GA023G, GA026G, GA029G, GA032G, GA050G, GA5090, GA5091, GA5092, GA5093, GA5094, GA5095	1910Y0-7
-	Wheel cover 115CKL set	DGA504, DGA506, DGA508, DGA513, DGA514, DGA517	198783-5
-	Toolless wheel cover 115AK set		198784-3
	Cutting wheel cover attachment 100 set	9553HN, 9556HB, 9556HN, 9556HNR, 9556HP, DGA402, DGA404, DGA405, DGA406, DGA408, DGA411, DGA412, DGA413, DGA414, DGA417, DGA418, DGA419, GA003G, GA006G, GA011G, GA014G, GA021G, GA024G, GA027G, GA030G, GA039G, GA042G, GA045G, GA048G, GA4030, GA4030R, GA4031, GA4034, GA4040, GA4040C, GA4050, GA4050R, GA4051R, GA4100	191V54-1
		DGA404, DGA405, GA039G, GA042G, GA045G, GA4030	191V55-9
	Cutting wheel cover attachment 115 set	9557HN, 9557HNR, 9557HP, 9564P, 9564PC, 9564PCV, DGA452, DGA454, DGA455, DGA456, DGA458, DGA463, DGA467, DGA469, GA004G, GA007G, GA012G, GA015G, GA022G, GA025G, GA028G, GA031G, GA040G, GA043G, GA046G, GA049G, GA4530R, GA4534, GA4540, GA4540C, GA4540R, GA4550, GA4550R, GA4551R, GA4590, GA4591, GA4592, GA4593, GA4594, GA4595, GA4600	199709-0
	Cutting wheel cover attachment 125 set	9558HN, 9558HNR, 9558HP, 9565CR, 9565CV, 9565CVR, 9565HR, 9565PC, 9565PCV, DGA504, DGA505, DGA506, DGA508, DGA511, DGA512, DGA513, DGA514, DGA517, DGA518, DGA519, DGA520, DGA521, GA005G, GA008G, GA013G, GA016G, GA023G, GA026G, GA029G, GA032G, GA041G, GA044G, GA047G, GA050G, GA5010, GA5020, GA5021, GA5021C, GA5030, GA5030R, GA5034, GA5040, GA5040C, GA5040R, GA5041C, GA5050, GA5050R, GA5051R, GA5080R, GA5090, GA5091, GA5092, GA5093, GA5094, GA5095, GA5100	199710-5
	Cutting wheel cover attachment 150 set	9566PC, 9566PCV, GA035G, GA036G, GA051G, GA6010, GA6020, GA6021, GA6021C, GA6040, GA6040C	191V56-7
		9566PCV, GA035G, GA036G, GA6020, GA6021, GA6021C, GA6040C	191X09-8
	Cutting wheel cover attachment 150A set	GA051G	191V57-5

Grip, loop handle for angle grinder

Still photo	Name	Related models	Thread size	Part No.
	Grip 35 set	All 100mm-150mm Angle Grinder	M8	1910X5-0
				1910X6-8
	Grip 36 set (Rubberized)			198043-5
	Vibration proof grip set	All 100mm-150mm Angle Grinder	M8	194514-0
		All 180mm-230mm Angle Grinder	M14	194543-3

Still photo	Name	Related models	Thread size	Part No.
	Loop handle set	GA5010, GA5011, GA5020, GA5020C, GA5021, GA5021C, GA6010, GA6020, GA6020C, GA6021, GA6021C	M8	194483-5
	Grip attachment set	GA9020, GA9020S, GA9030	M14	194684-5
	Loop handle set	GA9060R	M14	199176-9

Lock nut release socket

Still photo	Name	Compatible lock nut	Part No.
	Lock nut release socket 35 set	35	194305-9

Dust cover for angle grinder

Still photo	Related models	Part No.
	GA7080, GA9080	191T14-1
	GA7070, GA7071, GA9070, GA9071	191T15-9
	GA7060, GA7060R, GA7061, GA7061R, GA7064, GA7081, GA7082, GA9060, GA9060R, GA9061, GA9061R, GA9062R, GA9081, GA9082	197476-1
	GA9050R	195059-1
	GA7031, GA9031	194289-1
	GA5010, GA5011, GA5021, GA5021C, GA6010, GA6021, GA6021C, GA7010C, GA7012C, GA9010C, GA9012C	193956-5
	GA5020, GA6020	194482-7
	GA4040, GA4040C, GA4540, GA4540C, GA4540R, GA4542C, GA5040, GA5040C, GA5040R, GA5041C, GA5042C, GA6040, GA6040C, GA6040R, GA6042C, PC5010C, SA5040C	198719-4
	GA5050R, GA5051R	199514-5
	GA4590, GA4591, GA4592, GA5090, GA5091, GA5092	191V72-9
	GA4593, GA4594, GA4595, GA5093, GA5094, GA5095	191Y29-8
	9565C, 9565CR, 9565CV, 9565CVR, GA5080R	193903-6
	9564P, 9564PCV, 9565PCV, 9566PCV	195446-4

Collet cone, Collet nut for die grinder

Still photo	Name	Related models	Part No.
	Collet cone 8 set	GD0800C, GD0801C, GD0810C, GD0811C	192988-9
	Collet cone 6 set		193012-1
	Collet cone 3 set		193011-3
	Collet cone 1/4" set		192986-3
	Collet cone 1/8" set		192987-1
	Collet cone 1/8" set	GD0800, GD0800C, GD0801C, GD0810C, GD0811C	193144-4
	Collet cone 1/4" set	GD0800C, GD0801C, GD0810C	197023-8

Collet one, Collet nut and Wrench size



Model No.	Size	Collet cone	Collet nut	Wrench size
		Part No.	Part No.	
GD0600, GD0601	3mm	763627-4	763664-8	13mm x2
	6mm	763620-8		
	1/8"	763626-6		
	1/4"	763625-8		
GD0603	3mm	763627-4	763236-9	10mm x2
	6mm	763620-8		
	1/8"	763626-6		
	1/4"	763625-8		
DGD800, DGD801, GD0602	3mm	763669-8	763668-0	13mm x2
	6mm	763670-3		
	8mm	763671-1		
	1/8"	763672-9		
	1/4"	763673-7		
GD0800, GD0800C, GD0810C, GD0801C, GD0811C	3mm	763647-8	763645-2	13mm 19mm
	6mm	763646-0		
	8mm	763649-4		
	1/8"	763651-7		
	1/4"	763650-9		

Punch plate for sander

Still photo	Name	Related models	Description	Part No.
	Punch plate set	9046, BO4900, BO4900V, BO4901	Metal	192523-3
				194947-9
				194948-7
		BO3710, BO3711, DBO380, DBO381	Plastic	

Side handle set for die grinder

Still photo	Name	Related models	Part No.
	Side handle set	DGD800, DGD801, GD0600, GD0601, GD0602, GD0800, GD0800C, GD0801C, GD0810C, GD0811C	192985-5

Dust box assembly, paper dust bag, filter for sander

Still photo	Name	Related models	Part No.
	Paper dust bag set	9046, BO4900, BO4900V, BO6030	193293-7
	Paper dust bag holder set	9046, BO4900, BO4900V, BO6030	193294-5
		BO4900, BO4900V	193525-2
	Paper dust bag set	BO4900, BO4900V	193526-0
		BO4555, BO4556, BO4557, BO4558, BO4559, BO4560, BO4561, BO4562, BO4563, BO4564, BO4565, BO4566, DBO180, DBO480, DBO481, DBO482, DBO484	194746-9
	Filter set	BO3710, BO3711, BO4555, BO4556, BO4557, BO4558, BO4559, BO4560, BO4561, BO4562, BO4563, BO4564, BO4565, BO4566, BO5030, BO5031, BO5040, BO5041, DBO180, DBO380, DBO381, DBO480, DBO481, DBO482, DBO484	195133-5
			195134-3

Extension handle set for drywall sander

Still photo	Name	Related models	Part No.
	Extension handle set	DSL801	199937-7

Dust cover, protector for polisher, sander

Still photo	Name	Related models	Part No.
	Dust cover set	PW5000C, PW5001C	194233-8
	Dust collect cover set	PK5011C	195774-7
	Protector set	PK5011C	196028-5

Stand for belt sander

Still photo	Name	Related models	Part No.
	Belt sander stand set	9404, 9903, 9920	193055-3

Guide rule for sander

Still photo	Name	Related models	Part No.
	Guide rule set	BS001G	1915E3-1

Sanding shoe

Still photo	Name	Related models	Part No.
	Sanding shoe set	BS001G	193070-7

Clamp complete for belt sander

Still photo	Name	Related models	Part No.
	Clamp complete set	9910, 9911, BS001G	192694-6

Cutting

Water supply set for cutter



Name	Related models	Part No.
Water supply pipe set	4100NH3	196431-0
		196432-8

Rear cover

Name	Related models	Part No.
Rear cover attachment set	4100KB, 4100NH2	196944-1

Base cover

Still photo	Name	Related models	Part No.
	Base cover set	4100NH2, DCC500, DCC501	196943-3

Tilt base set for cutter

Still photo	Name	Related models	Part No.
	Tilt base set A	4100NH2	199494-5
	Tilt base set B		199495-3
	Tilt base set C		199496-1
	Tilt base set D		199713-9
	Tilt base set E		199714-7

Guide rail adapter for cutting

Still photo	Name	Related models	Part No.
	Guide rail adapter set	4100KB, 4100NH2, DCC500, DCC501	198673-2

Portable band saw stand

Still photo	Name	Related models	Part No.
	Stand of chain vise set	2107F	194026-3
			196326-7
-	Stand of parallel assembly		196327-5

Blade wax

Still photo	Name	Related models	Part No.
	Cutting wax set	2107F, DPB180, PB002G	191897-9

Cart set



Still photo	Related models	Part No.
	CE001G	1914H2-8
		1915C0-3
		1915C1-1

Shear

Still photo	Name	Related models	Description	Part No.
	Shear head assembly 16 set	DJS130	For mild steel: 1.6mm / 16ga;	194694-2
-	Shear head assembly set		For mild steel: 1.3mm / 18ga;	194695-0
	Shear blade set	JS3201	-	792287-5

Threaded rod cutter blade

Still photo	Name	Related models	Thread type	Thread size	Part No.	
	Cutter blade M10 set	DSC102, SC103D	ISO metric	M10	199083-6	
	Cutter blade M8 set			M8	199085-2	
	Cutter blade M6 set			M6	199087-8	
	Cutter blade W5/16 set	DSC121	ISO inch / BSW	5/16"-18 UNC / W5/16	199443-2	
	Cutter blade W1/4 set			1/4"-20 UNC / W1/4	199444-0	
	Cutter blade W3/8 set			3/8"-16 UNC / W3/8	199081-0	
	Cutter blade M8 set			M8	SC09002700	
	Cutter blade M10 set	DSC121	ISO metric	M10	SC09002710	
	Cutter blade M12 set			M12	SC09002720	
	Cutter blade W3/8 set			BSW	W5/16	SC09002750
	Cutter blade W3/8 set				W3/8	SC09002730
	Cutter blade W1/2 set				W1/2	SC09002740

Cutter blade set (2pcs set) for steel rod cutter

Still photo	Name	Related models	Part No.
	Cutter blade set	DSC163	SC09002470
		DSC191, DSC191R	SC09002030
		SC001G	SC09003470

Cutter blade for CP100D

Still photo	Name	Related models	Part No.
	Multi cutter blade set	CP100D	198603-3

For PP001G, DPP200 Combination of punch and die

- Punching holes through a thin structural metal plate may cause deformation of the plate and burr on the holes.
- If you need precision punching, see the tables below to select an optimum combination of punch and die.



● Round punching

Workpiece thickness (mm)	Punch		Die		Workpiece thickness (mm)				Punch		Die	
	Aluminum, Mild Steel	Hole size (mm) / Part No.	Hole size	Part No.	Mild Steel	Stainless Steel (Inox)	Channel		Hole size (mm)	Part No.	Hole size	Part No.
							PP001G	DPP200				
2-3.2	6	SC05340040	SA6	SC00000202	2-4	3-4	-	-	6	SC05340040	SB6	SC00000203
2-3.2	6.5	SC05340050	SA6.5	SC00000204	2-6	3-4	-	-	6.5	SC05340050	SB6.5	SC00000205
2-3.2	8	SC05340060	SA8	SC00000206	2-6	3-4	-	-	8	SC05340060	SB8	SC00000207
2-3.2	8.5	SC05340070	SA8.5	SC00000208	2-6	3-4	-	-	8.5	SC05340070	SB8.5	SC00000209
2-3.2	10	SC05340080	SA10	SC00000210	2-6	3-4	8	7.5	10	SC05340080	SB10	SC00000211
2-3.2	11	SC05340090	SA11	SC00000212	3-9	3-6	8	7.5	11	SC05340090	SB11	SC00000213
2-3.2	12	SC05340100	SA12	SC00000214	3-9	3-6	8	7.5	12	SC05340100	SB12	SC00000215
2-3.2	13	SC05340110	SA13	SC00000216	3-9	3-6	8	7.5	13	SC05340110	SB13	SC00000217
2-3.2	14	SC05340120	SA14	SC00000218	3-9	3-6	8	7.5	14	SC05340120	SB14	SC00000219
2-3.2	15	SC05340130	SA15	SC00000220	3-9	3-6	8	7.5	15	SC05340130	SB15	SC00000221
2-3.2	18	SC05340150	SA18	SC00000222	3-9	3-6	8	7.5	16	SC05340140	SB16	SC05332710
2-3.2	20	SC05340160	SA20	SC05352500	3-9	3-6	8	7.5	18	SC05340150	SB18	SC00000223
					3-9	3-6	8	7.5	19	SC05340170	SB19	SC05332740
					3-9	3-6	8	7.5	20	SC05340160	SB20	SC05352510

PP001G only

10	3-6	10	-	12	SC05340400	SB12	SC00000215
10	3-6	10	-	13	SC05340410	SB13	SC00000217
10	3-6	10	-	14	SC05340420	SB14	SC00000219
10	3-6	10	-	15	SC05340430	SB15	SC00000221
10	3-6	10	-	16	SC05340440	SB16	SC05332710
10	3-6	10	-	18	SC05340450	SB18	SC00000223
10	3-6	10	-	19	SC05340460	SB19	SC05332740

○ Oblong punching

Workpiece thickness (mm)	Punch		Die		Workpiece thickness (mm)				Punch		Die	
	Aluminum, Mild Steel	Hole size (mm) / Part No.	Hole size	Part No.	Mild Steel	Stainless Steel (Inox)	Channel		Hole size (mm)	Part No.	Hole size	Part No.
							PP001G	DPP200				
2-3.2	6.5x10	SC05340200	A6.5x10	SC00000243	2-6	3-4	-	-	6.5x10	SC05340200	B6.5x10	SC00000244
2-3.2	6.5x13	SC05340210	A6.5x13	SC00000245	2-6	3-4	-	-	6.5x13	SC05340210	B6.5x13	SC00000246
2-3.2	8.5x13	SC05340220	A8.5x13	SC00000247	2-6	3-4	-	-	8.5x13	SC05340220	B8.5x13	SC00000248
2-3.2	8.5x17	SC05340230	A8.5x17	SC00000249	2-6	3-4	-	-	8.5x17	SC05340230	B8.5x17	SC00000250
2-3.2	9x13.5	SC05340240	A9x13.5	SC00000251	2-6	3-4	-	-	9x13.5	SC05340240	B9x13.5	SC00000252
2-3.2	9x18	SC05340250	A9x18	SC00000253	2-6	3-4	-	-	9x18	SC05340250	B9x18	SC00000254
2-3.2	10x15	SC05340260	A10x15	SC00000255	2-8	3-6	8	7.5	10x15	SC05340260	B10x15	SC00000256
2-3.2	10x20	SC05340270	A10x20	SC00000257	2-8	3-6	8	7.5	10x20	SC05340270	B10x20	SC00000258
2-3.2	11x16.5	SC05340280	A11x16.5	SC00000259	2-9	3-6	8	7.5	11x16.5	SC05340280	B11x16.5	SC00000260
2-3.2	12x18	SC05340290	A12x18	SC00000261	2-9	3-6	8	7.5	12x18	SC05340290	B12x18	SC00000262
2-3.2	13x19.5	SC05340300	A13x19.5	SC00000263	2-9	3-6	8	7.5	13x19.5	SC05340300	B13x19.5	SC00000264
2-3.2	14x21	SC05340310	A14x21	SC00000265	2-9	3-6	8	7.5	14x21	SC05340310	B14x21	SC00000266
					2-9	3-6	8	7.5	15x21	SC05340320	B15x21	SC05340550

○ Vertical oblong punching

Workpiece thickness (mm)				Punch		Die	
Mild Steel	Stainless Steel (Inox)	Channel		Hole size (mm)	Part No.	Hole size	Part No.
		PP001G	DPP200				
2-9	3-6	8	7.5	20x12	SC05340350	B20x12	SC05340510
2-9	3-6	8	7.5	20x14	SC05340360	B20x14	SC05340530

Work stand set

Model No.	Part No.
PP001G, DPP200	SC03801080



Slide stopper

Model No.	Part No.
PP001G, DPP200	SC03300790

Punching up to 40 mm depth from the edge of the workpiece can be done using the optional slide stopper.

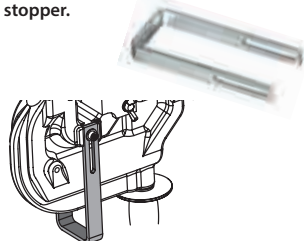



Hydraulic oil

Model No.	Viscosity	Size (mL)	Part No.
DPP200, DSC121, DSC163, DCS191, DSC191R, PP001G	ISO46	35	SC00000106
		150	SC00000142
		1,000	SC00000270
SC001G	ISO32	35	SC09003270
		150	SC09003280
		1,000	SC09003290



Sawing



Crown molding stopper set

Still photo	Name	Related models	Part No.
	Crown molding stopper set	LS1030N, LS1040, LS1040F, LS1045	192622-1
		DLS110, DLS111, DLS112, DLS211, DLS212, LS003G, LS004G, LS1019, LS1019L, LS1219, LS1219L	192628-9

Sub plate for miter saw

Still photo	Name	Related models	Part No.
	Sub plate set	LS1040, LS1040F	193471-9
			195934-1

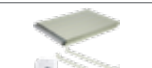
Extension table

Still photo	Name	Related models	Part No.
	Sub table R set	2703	192797-6
	Sub table L set		192798-4
	Left table set	2704, 2704N	194086-5
	Rear table set		194087-3

Dado flange set

Still photo	Name	Related models	Part No.
	DADO flange set	2703	192693-8



Sub base set

Still photo	Name	Related models	Part No.
	Sub base assembly set	DLS110, DLS111, DLS112, DLS211, DLS212, LS1019, LS1019L, LS1219, LS1219L	191C01-8

Saw storage holder

Still photo	Name	Related models	Part No.
	Protective stand set	5402NA	194701-1



Rip fence

Still photo	Name	Related models	Part No.
	Guide rule set	4327, 4329, JV0600, JV101D, JV103D	192732-4
		4350CT, 4350FCT, 4350T, 4351CT, 4351FCT, 4351T, DJV180, DJV181, DJV182, JV002G	193516-3
		DRS780, RS001G, RS002G	199249-8

Anti-splintering device for jig saw

Still photo	Name	Related models	Part No.
	Kerf board set	4326, 4327, 4329, 4350CT, 4350FCT, 4350T, 4351CT, 4351FCT, 4351T, DJV180, DJV181, DJV182, DJV184, DJV185, JV001G, JV002G, JV0600, JV101D, JV102D, JV103D, JV183D	192557-6

Dust bag for sawing

Still photo	Name	Related models	Part No.
	Dust bag assembly	DLS110, DLS111, DLS112, DLS211, DLS212, DLS713, DLS714, LF1000, LH1040, LH1040F, LS003G, LS004G, LS0714, LS0714F, LS0714FL, LS0714L, LS1019, LS1019L, LS1030N, LS1040, LS1040F, LS1045, LS1219, LS1219L, LS1221	122852-0
		DLS600	122884-7
		LS002G	127512-9

Dust box for miter saw

Still photo	Name	Related models	Part No.
	Dust box set	LS0714, LS0714F, LS0714FL	194175-6



Flourescent light set

Still photo	Name	Related models	Part No.
	Flourescent light set	2107F	193595-1

Multi tool blade adapter

Still photo	Name	Related models	Part No.
	Adapter A set	DTM50, DTM51, TM3000C, TM3010C, TM30D	196271-6

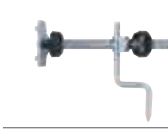
For LB1200F

Still photo	Name	Related models	Part No.
	Extension table set		JM21000300
	Circular cutting attachment set	LB1200F	JM21000320
	Belt sanding attachment set		JM21000330

Workshop stand

Still photo	Name	Related models	Part No.
	Stand set WST01N	DLS110, DLS111, DLS112, DLS211, DLS212, DLS713, DLS714, LS002G, LS003G, LS004G, LS0714, LS0815F, LS0815FL, LS1019, LS1019L, LS1040, LS1219, LS1219L, LS1221	198686-3
		DLS110, DLS111, DLS211, DLS212, DLS713, DLS714, LS002G, LS003G, LS004G, LS0815FL, LS1019, LS1019L, LS1040, LS1219, LS1219L	198687-1
	Stand set WST05	DLS110, DLS111, DLS112, DLS211, DLS212, DLS713, DLS714, LS002G, LS003G, LS004G, LS0714/FL/L/F, LS0815FL/F, LS0816F, LS1017L, LS1018L, LS1019, LS1019L, LS1030N, LS1040/F, LS1045, LS1110F, LS1440, LS1221, LS1219/L	WST05
	Stand set WST06		WST06
	Stand set WST07		WST07
	Stand set WST03		MLT100, MLT100N, 2702, 2703
	Stand set WST04	2704, 2704N	194093-8

Guide rail



Overall length (m)	Part No.
1.0	199140-0
1.4	194368-5
1.5	199141-8
1.9	194925-9
3.0	194367-7

Repair parts for guide rail

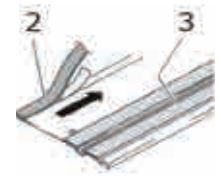
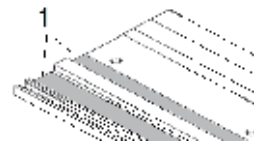

Item	Part No.	
1	Seat 10m set (For upper plastic tape repair)	
	Position Seat 1.4m	191J53-1(USA)
	Position Seat 1.9m	194910-2 194915-2(EU)
	Position Seat 3.0m	194419-4
3	Rubber Seat 10m set (For lower rubber tape repair)	
		194417-8 191J54-9(USA)

Clamp set

(Use with Guide rail)

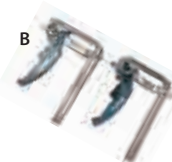

Type	Part No.
A: Standard	194385-5
B: Quick	199826-6
C: Push clamp	1913K5-7

Sawing

Bevel guide set

Adjustable angle of Guide Rail
The Parallel guide set cannot be used with the Limit stop set.

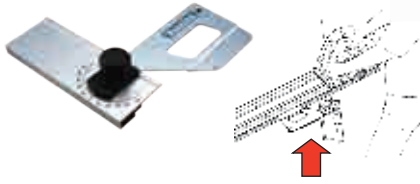

Part No.
196664-7

Parallel guide set

Guide rail parallelly to any position from the end face of workpiece.
Stable size cutting can be done by setting.
The Parallel guide set cannot be used with the Limit stop set.



Part No.
1913K7-3

Guide rail Joint connector 2pcs set

The Parallel guide set cannot be used with the Limit stop set.

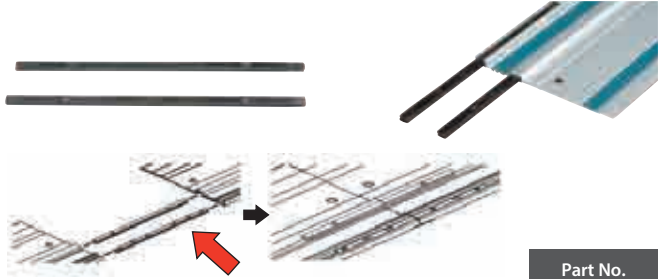

Part No.
198885-7

Limit stop set

Can reduce the risk of unintentional backward movement by using with Guide rail.

Use with optional accessories that block the groove of the Guide rail, such as the Guide rail adaptor, Parallel guide, and Bevel guide, is not possible.



Model No.	Part No.
CA5000, DHS782, DHS783, DHS900, DSP600, DSP601, HS004G, HS009G, HS011G, SP001G, SP6000,	1913J9-2

Guide Rail Adaptor

*w/carton

Items	A	B	C	D	E	F (N)	G	H	I	J	K	N (F)		O	P	Q	R
	Circular saw												Jig saw		Router Trimmer	Cutter	
Models	HS7100 HS7101	DHS630 HS6100 HS6101	HS7601 HS7610 HS7611	DHS680	HS6600 HS6601	DHS630 HS6100 HS6101 HS7100 HS7101	HS0600	5705R	DHS660 DHS661	5903R	5103R	DJV141 DJV142 DJV180 DJV181 DJV182 JV001G JV002G 4350CT 4350FCT 4350FT 4350T 4351CT 4351FCT 4351T	DJV184 DJV185 JV102D JV103D	3612BR RP0900 RP0910 RP1110C RP1111C RP1800 RP1800F RP1801 RP1801F RP1802 RP1802F RP1803 RP1803F RP2300FC RP2301FC RP2302FC RP2303FC	DCC500 DCC501 4100KB, 4100NH2		
Part No.	195837-9	195838-7	197005-0 *191B18-5	196953-0 *191B17-7	197462-2 *191B19-3	197252-3	198566-3 198570-2 (EU)	192505-5	199232-5	192506-3	192507-1	197252-3	193517-1	198704-7	194579-2	198673-2	
Conversion	Items B/C/D/E + Part No. 195840-0	Items A/C/D/E + Part No. 195841-8	Items A/B/D/E/F(N) + Part No. 196994-6	Items A/B/C/E/F(N) + Part No. 196954-8	Items A/B/C/D/F(N) + Part No. 197463-0	Items C/D/E + 195840-0 + 195841-8			Items J/K + 126971-4			Items A,B,C,D,E + 347393-7	Item P + Bolt MSX10 922207-7	Item O + Bolt M4X8 922107-1			

** Use with Plunge base assembly (P/N:195563-0 EU:196094-2)

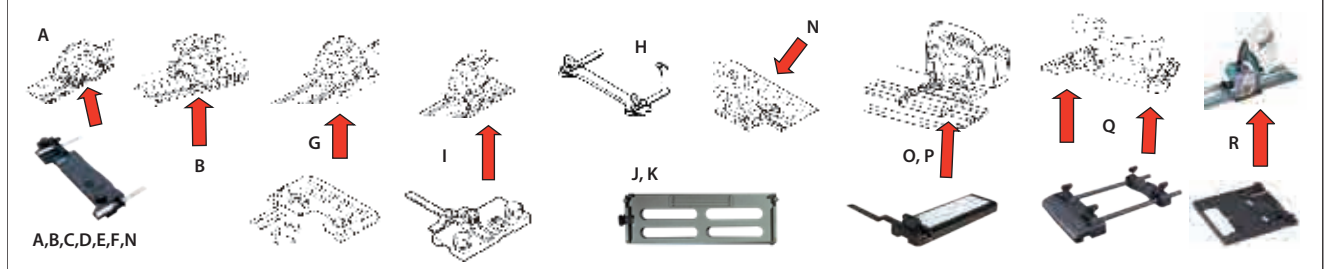

Set plate

Still photo	Name	Related models	Part No.
	Set plate set	DKP180, DKP181, KP001G, KP0800	193540-6





Dust bag for milling, planing

Still photo	Name	Related models	Part No.
	Dust bag set	1911B	196300-5

Edge fence, guide rule

Still photo	Name	Related models	Part No.
	Guide rule set	1804N, 1805N	191454-3

Straight guide assembly for trimmer, router

Still photo	Name	Related models	Type	Part No.
	Straight guide set	RD1101, RF1101, RP1101	-	193073-1
		DRT50, RD1101, RF1101, RP0900, RP1800, RP2301FC, RT001G, RT0700C	Micro adjustment	193312-9
		DRT50, RD1101, RF1101, RP0900, RP1101, RT001G, RT0700C		193358-5
		RP1800, RP1800F, RP1802, RP1802F, RP1803, RP1803F, RP2300FC, RP2301FC, RP2302FC, RP2303FC		194935-6
		DRT50, RP0900, RP0910, RP1111C, RP1800, RP1800F, RP1802, RP1802F, RP1803, RP1803F, RP2300FC, RP2301FC, RP2302FC, RP2303FC, RT001G, RT0700C, RT0702C		195136-9



Trimmer guide holder

Still photo	Name	Related models	Part No.
	Guide holder set	DRT50, RT001G, RT0700C, RT0702C	195564-8





Circular guide set for cut-out tool

Still photo	Name	Related models	Part No.
	Circular guide set	3706	193448-4



Drywall guide bit

Still photo	Name	Related models	Overall diameter mm (inch)	Shank diameter mm (inch)	Range	Bearing	Part No.
	Drywall guide bit 3.18 set	3706, DCO180, DCO181	3.18 (1/8)	3.18 (1/8)	★★★☆☆	N	191G69-8
	Drywall guide bit 6.35 set	DCO180, DCO181	6.35 (1/4)	6.35 (1/4)			193447-6



Router base assembly

Still photo	Name	Related models	Part No.
	Base plate set	RD1101, RF1101, RP1101	193155-9
	Base set	RP1101	193457-3
	Plunge base set	DRT50, RT001G, RT0700C, RT0702C	195563-0
			196094-2

Trimmer base assembly

Still photo	Name	Related models	Type	Part No.
	Trimmer base assembly set	3709, 3710, 3711, 3712	Transparent base Fine depth adjustment	194267-1
			Transparent base	194268-9
			For chamfering Fine depth adjustment	194269-7
			For chamfering	194270-2
	Trimmer base set (12 pcs)	DRT50, RT001G, RT0700C, RT0702C	(12 PCS)	196615-0
	Tilt base set		-	198987-9

Offset base assembly

Still photo	Name	Related models	Part No.
	Offset base set	DRT50, RT001G, RT0700C, RT0702C	195562-2
			196093-4
		RT0700C	196922-1

Milling/Planing

Collet cone & Collet nut

*With Poly bag & header



Model No.	Wrench size	Collet cone		Collet nut
		Size	Part No.	Part No.
DCO180, DCO181	17mm	3mm	763679-5	763258-9
		6mm	763678-7	
		1/8"	763677-9	
		1/4"	763676-1	
		1/4"	*197038-5	
3706	17mm	6mm	763607-0	763606-2
		1/8"	763660-6	
		1/4"	763608-8	

Collet corn / Collet nut

Trimmer, Sash router and Router



Model No.	Wrench size	Collet cone		Collet nut
		Size	Part No.	Part No.
DRT52, N3701, 3709, 3710, 3711, 3712	10mm 17mm	6mm	763607-0 763662-2	763606-2 763661-4
		1/4"	763608-8 763663-0	763661-4
DRT50, RT001G, RT002G, RT0700C, RT0702C, RP0900	13mm 22mm	6mm	763636-3	763615-1
		8mm	763618-5	
		1/4"	763637-1	
		3/8"	763619-3	
RP001G, 3600H	13mm 24mm	12mm	763628-2	763629-0
		1/2"	763622-4	
RP0910, RP1110C, RP1111C	17mm	6mm	193180-0	763652-5
		8mm	193178-7	
		1/4"	193179-5	
RD1101, RF1101, RP1101	27mm x2	1/4"	193214-9	
		1/2"	193215-7	
RP1800/ F, RP1802/ F, RP1801/ F, RP1803/ F, RP2300FC, RP2301FC, RP2302FC, RP2303FC	24mm	12mm	763628-2	763674-5
		1/2"	763622-4	

Collet sleeve



Model No.	Collet size	Bit size	Part No.
RP1800/ F, RP1802/ F, RP1801/ F, RP1803/ F, RP2300FC, RP2301FC, RP2302FC, RP2303FC, 3600H, 3601B, RP001G	1/2"	1/4"	763803-0
		3/8"	763805-6
		10mm	763806-4
	12mm	6mm	763801-4
		8mm	763804-8
		10mm	763807-2
		1/4"	763808-0

Templet guide (Metric size)

*for fast production of complicated shapes by using templet

**DRT50, RT001G, RT0700C, RT0702C: Use with Plunge base assembly

Model No.	Still photo	A (mm)	B (mm)	C (mm)	Part No.		
DRT50, DRT52, 3709, 3710, 3711, 3712, N3701, RT001G, RT0700C, RT0702C		8	10	9.5	*343577-5		
DRT50**, RP001G, RP0900, RP1800/ F, RP1802/ F, RP1801/ F, RP1803/ F, RP2300FC, RP2301FC, RP2302FC, RP2303FC, RT001G**, RT0700C**, RT0702C**		7.7	9.5	11.5	164379-4		
		9	11	13	164775-6		
		10	12	9	164388-3		
		11	12.7	13	164776-4		
		14	17	20	165366-6		
		14.5	16	13	193043-0		
		18	20	13	164393-0		
		22	24	13	165364-0		
		24	27	13	164470-8		
		27	30	13	164471-6		
		37	40	13	165046-4		
		37	40	13	164472-4		
		RP0910, RP1110C, RT1111C		7.7	9.5	11.5	193330-7
				9	11	11.5	193331-5
10.5	12			14	193332-3		
11	12.7			11.5	193333-1		
14	17			20	165365-8		
14.5	16			11.5	193334-9		
18	20			13	193335-7		
22	24			13	193340-4		
24	27			13	193336-5		
25	29			13	193337-3		
27	30			13	193338-1		
37	40			13	193339-9		

Templet guide (Metric size)

Model No.	Still photo	A (mm)	B (mm)	C (mm)	Part No.
3600H, 3601B		7.7	9.5	8	323448-2
		9	11	5	323023-4
		11.1	12.7	14.3	321472-9
		10.9	12.7	8	323449-0
		14	16	8	323018-7
		14	16	14.5	321308-2

Templet guide (Inch size)

Model No.	Still photo	A	B	C	Part No.
RF1101, RD1100, RD1101, RP1100, RP1101		57/64"	1"	7/16"	193235-1
		21/32"	3/4"	9/16"	193261-0
		11/32"	7/16"	5/32"	193262-8
		13/32"	1/2"	5/16"	193263-6
		9/32"	3/8"	5/16"	193264-4
		5/8"	54/64"	9/16"	193265-2
		17/32"	5/8"	9/16"	193266-0
		1/4"	5/16"	5/32"	193267-8

Templet guide adapter 30

(For B & D, Porter-Cable two-piece templet guide)

Nut M30
Part No. 252627-4
Templet guide adapter 30
Type A or Type B

Templet guide 25
Part No. 321812-1

Plunge base assembly (P/N: 195563-0 (EU:196094-2)) is also necessary.

Model No.	Type	Part No.
DRT50**, RP0900, RP1800/ F, RP1802F, RP1801/ F, RP1803/ F, RP2300FC, RP2301FC, RP2302FC, RP2303FC, RT001G**, RT0700C**, RT0702C**, 3600H, 3601B	A	321492-3
	B	321493-1

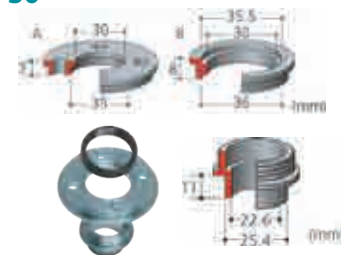

Rivet gun maintenance kit

* short madrel

**Model DRV150: Pipe is not necessary for operation.

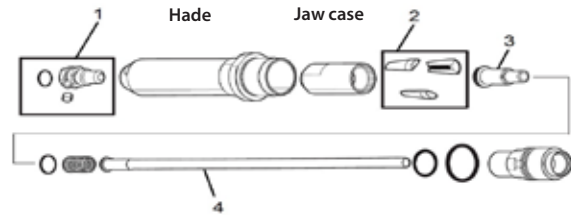

Shape	Model No.	Rivet size	1		Hade / Jaw case		2	3	4	1+3+4	1+3													
			Nose piece size	(-DEC. 2023)		Color / Jaw size	Color / Jaw pusher size	Color / pipe size	Nose piece, Jaw pusher and pipe set	Nose piece and jaw pusher set														
				Part No.	Part No.						Part No.	Part No.	Part No.	Part No.										
	DRV150, DRV250	2.4 mm	2.4	Marking on 6.4 327279-1 / 327281-4	Marking on 4.85 327691-5 / 327883-0	Black / 4.8 199731-7	Gray / 1.9 127478-3	Silver / 2.3 162747-5	199729-4	1911U6-3	191C04-2													
			*2.4 mm									2.4 S	127230-9	127478-3	162747-5									
		3.2 mm	3.2									122D82-7	127478-3	162747-5										
			*3.2 mm									3.2 S	127229-4	127477-5	162746-7									
		4.0 mm	4.0									122D81-9	127477-5	162746-7										
			*4.0 mm									4.0 S	127228-6	127477-5	162746-7									
		4.8 mm	4.8									122D80-1	127476-7	**162745-9										
			*4.8 mm									4.8 S	127225-2	127476-7	**162745-9									
		DRV250	6.0 mm									6.0	Marking on 6.4 327279-1 / 327281-4	Marking on 6.45 327830-7 / 327831-5	Silver / 6.4 199730-9	Gray / 4.0 127474-1	Black / 4.2 162744-1	199725-2	1911V0-2	191F78-1	1911U8-9			
												*6.0 mm										6.0 S	122D79-6	127474-1
			6.4 mm									6.4										127223-6	127474-1	162744-1
												*6.4 mm										6.4 S	127223-6	127473-3
	6.4 mm		6.4	127223-6	127473-3	162743-3																		
			*6.4 mm	6.4 S	122B72-8	127473-3	162743-3																	

Grease set

Still photo	Description	Related models	Part No.
	5g for Jaw grease	DRV150, DRV250	191D57-7 191D58-5

Reber binding attachment set

Still photo	Name	Shank type	Part No.
	Rebar binding attachment set	E-form (MZ)	194731-2

Tool protector

Still photo	Name	Related models	Color	Part No.
	Protector set A	DRV150	Clear	191G65-6
			Red	191S61-6
			Blue	191S62-4
	Protector set B	DRV250	Clear	191G66-4
			Red	191S63-2
			Blue	191S64-0

Nailer maintenance kit

Still photo	Name	Related models	Part No.
	Cleaning set	GF600, GN420C	194852-0 194853-8 195140-8

Extension handle for rebar tying tool

Still photo	Name	Related models	Part No.
	Extension handle set	DTR180, DTR181	191M27-0 191M28-8

Wire guide

Still photo	Name	Related models	Part No.
	Wire guide B complete (EG) set	DTR181	1913F2-8

Tie wire set

Ø0.8mm, 50 pcs/ box

Still photo	Name	Related models	Wire length / bobbin	Description	Part No.
	Poly coated tie wire set	DTR180, DTR181	-	Poly coated	191J59-9
	Tie wire set	DTR180	Approx 100m	Galvanized	191L22-4
		DTR180, DTR181		Standard	199137-9

Fastening/Fixing

Nails, Staples and Screws

Wire coil Nails (Flat Type)

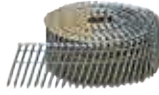

Dia	Length	Shank	Nails /carton	Part No.
-----	--------	-------	---------------	----------

For Model: AN560, AN611, AN760, AN902

2.5mm (0.099")	45mm (1-3/4")	Smooth	10,800	F-30810
	50mm (2")	Screw Chisel		F-30865
		Smooth		F-31243

For Model: AN611, AN621, AN635H, AN760, AN901, AN902, AN935H, AN953H, AN960, AN961

2.5mm (0.099")	57mm (2-1/4")	Screw Chisel	8,100	F-30878
		Smooth		F-31256
	65mm (2-1/2")	Screw Chisel		F-30900
		Smooth		F-31269

For Model: AN560, AN611, AN621, AN635H, AN760, AN901, AN902, AN935H, AN953H

2.8mm (0.110")	50mm (2")	Smooth	9,000	F-30823
2.9mm (0.113")		Screw Chisel		F-30849
		Smooth		F-30971

For Model: AN611, AN621, AN635H, AN760, AN901, AN902, AN935H, AN953H, AN960, AN961

2.9mm (0.113")	57mm (2-1/4")	Screw Chisel	6,750	F-31272
				F-30881
3.1mm (0.120")	65mm (2-1/2")	Smooth	6,075	F-30836
3.3mm (0.131")				F-30852

For Model: AN760, AN901, AN902, AN935H, AN953H, AN960, AN961

2.9mm (0.113")	71mm (2-13/16")	Screw Chisel	6,750	F-31285
3.1mm (0.120")		Smooth		F-31298
3.2mm (0.120")		Screw Chisel		F-31320

For Model: AN901, AN902, AN935H, AN953H, AN960, AN961

3.4mm (0.135")	75mm (3")	Smooth	3,600	F-31359
----------------	-----------	--------	-------	---------

For Model: AN902, AN960, AN961

Dia	Length	Shank	Nails /carton	Part No.
3.1mm (0.120")	85mm (3-1/4")	Smooth	4,050	F-31304
		Screw Chisel		F-31333
		Smooth		F-31317
3.2mm (0.120")	90mm (3-1/2")	Screw Chisel	2,700	F-31346
3.8mm (0.146")		Smooth		F-31362

Wire coil nails (Conical Type)

For Model: AN560, AN611

Dia	Length	Shank	Nails /carton	Part No.
2.1mm (0.083")	32mm (1-1/4")	Smooth	21,600	F-32766
	38mm (1-1/2")	Screw Chisel	18,000	F-32779
		Screw		F-32801

For Model: AN560, AN611, AN760

2.1mm (0.083")	45mm (1-3/4")	Smooth	18,000	F-32782
		Screw		F-32814
	50mm (2")	Smooth	14,400	F-32795
		Screw		F-32827

Wire coil nails (Roofing nail)

(7,200 pcs/box)

For Model: AN454



Dia	Length	Shank	Nails /carton	Part No.
3.1mm (0.120")	22mm (7/8")	Smooth	7,200	F-30762
	25mm (1")			F-30775
	32mm (1-1/4")			F-30788
	38mm (1-1/2")			F-30791
	45mm (1-3/4")			F-30807

Paper tape nail clipped-head

For Model: AN943



Dia	Length	Shank	Finish	Nails /carton	Part No.
2.9mm (0.113")	60mm (2-3/8")	Smooth	Bright	3,000	F-30566
3.1mm (0.120")	75mm (3")	Smooth	Bright		F-30579
			Galvanized		F-30582
	83mm (3-1/4")	Ring	Galvanized		F-30595
		Smooth	Bright		F-30601
3.3mm (0.131")	75mm (3")	Smooth	Bright		F-30614
			Galvanized		F-30627
	83mm (3-1/4")		Bright		F-30630
			Galvanized		F-30643
	90mm (3-1/2")		Bright		F-30656
			Galvanized		F-31645

Pin nail



Model No.	Type	Length	Part No.	
AF201Z, AF353, DPT353, PT354D, PT001G	23Ga(φ0.6) Pin Nail (10,000 pcs/box)	18mm (11/16")	F-31825	
		25mm (1")	F-31838	
DPT351, DPT353, PT354D, PT001G		30mm (1-3/16")	F-31841	
		35mm (1-3/8")	F-31854	
AF502HP		45mm (1-3/4")	F-32920	
		50mm (2")	F-32933	
AF201Z, DPT351, PT354D		23Ga(φ0.6) Stainless Pin Nail (10,000 pcs/box)	18mm (11/16")	F-32142
			25mm (1")	F-32155
DPT351, PT354D			30mm (1-3/16")	F-32168
			35mm (1-3/8")	F-32171

Finish nail

Model No.	Type	Length	Part No.		
AF601, DBN600	16 ga Finish Nail (2,000 pcs/box)	25mm (1")	F-33922		
		30mm (1-3/16")	F-33935		
		32mm (1-1/4")	F-33948		
		35mm (1-3/8")	F-33951		
		38mm (1-1/2")	F-33964		
		40mm (1-9/16")	F-33977		
		45mm (1-3/4")	F-33980		
		50mm (2")	F-33993		
		57mm (1-1/4")	F-34001		
		60mm (2-3/8")	F-34014		
		64mm (2-1/2")	F-34027		
		AF635	15Ga Finish Nail 34deg (4,000 pcs/box)	32mm (1-1/4")	F-31960
				38mm (1-1/2")	F-31973
				45mm (1-3/4")	F-31986
50mm (2")	F-31999				
57mm (1-1/4")	F-32007				
64mm (2-1/2")	F-32010				



Brad nail

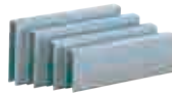

Model No.	Type	Length	Part No.
AF506, DBN500, DFN350, FN001G	18Ga Brad Nail (5,000 pcs/box)	15mm (5/8")	F-31867
		20mm (3/4")	F-31870
		25mm (1")	F-31883
		30mm (1-3/16")	F-31896
		32mm (1-1/4")	F-31902
AF506, DBN500, FN001G		35mm (1-3/8")	F-31915
		38mm (1-1/2")	F-31928
AF506, DBN500		40mm (1-9/16")	F-31931
		45mm (1-3/4")	F-31944
		50mm (2")	F-31957

Staple

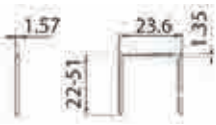

Model No.	Type	Length	Part No.
DST221 	10mm(3/8") Crown Staple (5,040 pcs/box)	10mm (3/8")	F-32647
		13mm (17/32")	F-32650
		16mm (5/8")	F-32663
		19mm (3/4")	F-32676
		22mm (7/8")	F-32689
AT1150A 	7/16" Medium Crown Staple 16Ga (10,000 pcs/box)	25mm (1")	F-32078
		28mm (1-1/8")	F-32081
		32mm (1-1/4")	F-32094
		35mm (1-3/8")	F-32100
		40mm (1-9/16")	F-32113
		45mm (3/4")	F-32126
AT2550A 	1" Wide Crown Staple 16Ga (10,000 pcs/box)	22mm (7/8")	F-32197
		25mm (1")	F-32023
		32mm (1-1/4")	F-32036
		38mm (1-1/2")	F-32049
		45mm (1-3/4")	F-32052
		51mm (2")	F-32065

GN900 Accessories

* for Europe, **for Australia

Description	Part No.	Part No.	Part No.
Fuel cell set	*194844-9	**194845-7	195088-4

Concrete pin

Includes one Fuel cell / box.
Box : 10pins/strip x 100 = 1,000pins
for Europe



Model No.	Description	Dia. (mm)	Length	Part No.
GN420C	Premium pin	3.1	15mm	196285-5
			17mm	196286-3
			22mm	196287-1
			27mm	196288-9
			32mm	196289-7
	Standard pin	2.6	20mm	196290-2
			25mm	196291-0
			30mm	196292-8
			35mm	196293-6
			40mm	196294-4

Concrete pin

1,000 pcs/box



Model No.	Dia. (mm)	Length	Part No.
GN420C	2.5	19mm	F-33562
		22mm	F-33575
		25mm	F-33588
	3	19mm	F-33591

Brad Nail fuel cell set

Fuel cell/ carton x2 set



Model No.	Type	Length	Part No.
GF600	16Ga Brad Nail Galvanized (2,000 pcs/box)	15mm	195667-8
		19mm	195668-6
		22mm	195669-4
		25mm	195670-9
		30mm	195671-7
		32mm	195672-5
		35mm	195673-3
		38mm	195674-1
		40mm	195675-9
		45mm	195676-7
		50mm	195677-5
		57mm	195678-3
	16Ga Brad Nail Stainless (2,000 pcs/box)	25mm	195681-4
		38mm	195682-2
		50mm	195683-0
		64mm	195684-8
		64mm	195680-6
		64mm	195679-1

Depth adjuster set

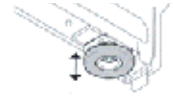

Model No.	Part No.
DST111, DST112, ST113D, ST313D	197731-1

Magazine set



Model No.	Magazine capacity	Part No.
GN420C	20 pins (2 strips)	196806-3
	40 pins (4 strips)	196805-5
DBN900	Extended capacity magazine set Maximum magazine capacity: 97 nails	1914P1-6
DBN901	Extended capacity magazine set Maximum magazine capacity: 78 nails	1914P9-0

O-rings set

Model No.	Part No.	
AN635H	for duster	196269-3 / 197789-0
	for exhaust hole	197984-2 / 198036-2
	for trigger	199389-2 / 199429-6

Fastening/Fixing

Flat Tape Collated Screws

Drywall Screws

Application	L (mm)	Shank Dia (mm)	Recess	Thread	Finish	Screws/- Belt	Screws/- Box	Part No.
Drywall to metal stud (Plasterboard to metal stud)	25	3.5	PH2	Fine	Phosphated	50pcs	1,000pcs	F-31227
	25	3.9	PH2	Fine	Phosphated	50pcs	1,000pcs	F-30913
	30	3.9	PH2	Fine	Phosphated	50pcs	1,000pcs	F-30926
	32	3.5	PH2	Fine	Phosphated	50pcs	1,000pcs	F-31018
	35	3.5	PH2	Fine	Phosphated	50pcs	1,000pcs	F-31230
	35	3.9	PH2	Fine	Phosphated	50pcs	1,000pcs	F-31153
	41	3.5	PH2	Fine	Phosphated	50pcs	1,000pcs	F-32232
	41	3.9	PH2	Fine	Phosphated	50pcs	1,000pcs	F-31166
	45	3.9	PH2	Fine	Phosphated	50pcs	1,000pcs	F-30939
	55	3.9	PH2	Fine	Phosphated	50pcs	1,000pcs	F-30942
Drywall to Steel frame (Plasterboard to Steel frame)	35	3.5	PH2	Fine/Self Drilling	Phosphated	50pcs	1,000pcs	F-31195
Drywall to wood (Plasterboard to wood)	30	3.9	PH2	Coarse	Phosphated	50pcs	1,000pcs	F-30955
	30	3.9	PH2	Coarse	Yellow Zinc (5 micron)	50pcs	1,000pcs	F-32203
	33	3.5	PH2	Coarse	Phosphated	50pcs	1,000pcs	F-31021
	35	3.9	PH2	Coarse	Phosphated	50pcs	1,000pcs	F-31179
	41	3.5	PH1	Coarse	Phosphated	50pcs	1,000pcs	F-31034
	41	3.9	PH2	Coarse	Phosphated	50pcs	1,000pcs	F-31182
	41	3.9	PH2	Coarse	Yellow Zinc (5 micron)	50pcs	1,000pcs	F-32216
	55	3.9	PH2	Coarse	Phosphated	50pcs	1,000pcs	F-31140
Drywall to wood (Plasterboard to hard wood)	30	3.9	PH2	Hi-Low	Yellow Zinc (5 micron)	50pcs	1,000pcs	F-32245
	41	3.9	PH2	Hi-Low	Yellow Zinc (5 micron)	50pcs	1,000pcs	F-32258
	55	3.9	PH2	Hi-Low	Yellow Zinc (5 micron)	50pcs	1,000pcs	F-32261
Chipboard Screws (Particleboard to wood)	30	4.2	PH2	Coarse, Part Thread	Yellow Zinc (5 micron)	50pcs	1,000pcs	F-32528
	42	4.2	PH2	Coarse, Part Thread	Yellow Zinc (5 micron)	50pcs	1,000pcs	F-32531
	55	4.2	PH2	Coarse, Part Thread	Yellow Zinc (5 micron)	50pcs	1,000pcs	F-32544
Fermacell Screws (Gypsum Fibreboard to hard wood)	30	3.9	PH2	Hi-Low	Phosphated	50pcs	1,000pcs	F-31748
	45	3.9	PH2	Hi-Low	Phosphated	50pcs	1,000pcs	F-31751
Hardboard Screws (HDF board to hard wood)	32	3.9	PH2	Hi-Low	Dacromate	50pcs	1,000pcs	F-31793
	41	3.9	PH2	Hi-Low	Dacromate	50pcs	1,000pcs	F-31809
Decking Screws (Wood to wood)	42	4.2	PH2	Coarse, Part Thread	Stainless Steel	50pcs	1,000pcs	F-32470
	55	4.2	PH2	Coarse, Part Thread	Stainless Steel	50pcs	1,000pcs	F-32483
Wood Screws (Playwood to hard wood)	40	4.2	PH2	Hi-Low	Zinc Plated	50pcs	1,000pcs	F-31201
	55	4.2	PH2	Hi-Low	Zinc Plated	50pcs	1,000pcs	F-31214
Wood Screws (Wood to wood)	45	4.2	SQ2	Coarse	Yellow Zinc	50pcs	1,000pcs	F-33205
	50	4.2	SQ2	Coarse	Yellow Zinc	50pcs	800pcs	F-33218
Wood Screws (Wood to wood)	41	4.2	SQ2	Coarse	Geomet	50pcs	1,000pcs	F-33276
	45	4.2	SQ2	Coarse	Geomet	50pcs	1,000pcs	F-33289
	50	4.2	SQ2	Coarse	Geomet	50pcs	800pcs	F-33292
	63	4.2	SQ2	Coarse	Geomet	50pcs	600pcs	F-33324
	75	4.2	SQ2	Coarse	Geomet	50pcs	600pcs	F-33340

	For Model								Autofeed attachment set	For Model				Part No.
	DFR440	DFR540	DFR550	DFR750	6842	6843	6844	6845		DFR452	DFR453	DFR551	DFR552	
	25-41mm	25-55mm	25-55mm	45-75mm	25-55mm	25-55mm	45-75mm	25-41mm		25-55mm	20-41mm	20-41mm	25-55mm	
Yes		Yes						Yes	Yes	Yes	Yes	Yes	F-31227	
Yes	Yes	Yes		Yes	Yes		Yes	Yes	Yes	Yes	Yes	Yes	F-30913	
Yes	Yes	Yes		Yes	Yes		Yes	Yes	Yes	Yes	Yes	Yes	F-30926	
Yes	Yes	Yes		Yes	Yes		Yes	Yes					F-31018	
Yes		Yes						Yes	Yes	Yes	Yes	Yes	F-31230	
Yes	Yes	Yes		Yes	Yes		Yes	Yes	Yes	Yes	Yes	Yes	F-31153	
Yes	Yes	Yes		Yes	Yes		Yes	Yes	Yes	Yes	Yes	Yes	F-32232	
Yes	Yes	Yes		Yes	Yes		Yes	Yes	Yes	Yes	Yes	Yes	F-31166	
Yes	Yes		Yes	Yes	Yes			Yes			Yes	Yes	F-30939	
Yes	Yes	Yes	Yes	Yes	Yes			Yes			Yes	Yes	F-30942	
Yes		Yes						Yes	Yes	Yes	Yes	Yes	F-31195	
	Yes	Yes		Yes	Yes			Yes	Yes	Yes	Yes	Yes	F-30955	
Yes	Yes	Yes		Yes	Yes		Yes	Yes	Yes	Yes	Yes	Yes	F-32203	
Yes	Yes	Yes		Yes	Yes		Yes						F-31021	
Yes	Yes	Yes		Yes	Yes		Yes	Yes	Yes	Yes	Yes	Yes	F-31179	
Yes	Yes	Yes		Yes	Yes		Yes						F-31034	
Yes	Yes	Yes		Yes	Yes		Yes	Yes	Yes	Yes	Yes	Yes	F-31182	
Yes	Yes	Yes		Yes	Yes		Yes	Yes	Yes	Yes	Yes	Yes	F-32216	
	Yes			Yes	Yes	Yes		Yes			Yes	Yes	F-31140	
	Yes	Yes	Yes	Yes	Yes	Yes		Yes			Yes	Yes	F-32229	
Yes	Yes	Yes		Yes	Yes		Yes	Yes	Yes	Yes	Yes	Yes	F-32245	
Yes	Yes	Yes		Yes	Yes		Yes	Yes	Yes	Yes	Yes	Yes	F-32258	
	Yes	Yes	Yes	Yes	Yes	Yes		Yes			Yes	Yes	F-32261	
Yes	Yes	Yes		Yes	Yes		Yes	Yes	Yes	Yes	Yes	Yes	F-32528	
	Yes	Yes		Yes	Yes			Yes			Yes	Yes	F-32531	
	Yes	Yes	Yes	Yes	Yes	Yes		Yes			Yes	Yes	F-32544	
Yes	Yes	Yes		Yes	Yes		Yes	Yes	Yes	Yes	Yes	Yes	F-31748	
Yes	Yes	Yes	Yes	Yes	Yes	Yes		Yes					F-31751	
Yes	Yes	Yes		Yes	Yes		Yes	Yes	Yes	Yes	Yes	Yes	F-31793	
Yes	Yes	Yes		Yes	Yes		Yes	Yes	Yes	Yes	Yes	Yes	F-31809	
	Yes	Yes		Yes	Yes			Yes			Yes	Yes	F-32470	
	Yes	Yes	Yes	Yes	Yes	Yes		Yes			Yes	Yes	F-32483	
Yes	Yes	Yes		Yes	Yes		Yes	Yes	Yes	Yes	Yes	Yes	F-31201	
	Yes	Yes	Yes	Yes	Yes	Yes		Yes	Yes	Yes	Yes	Yes	F-31214	
	Yes	Yes	Yes	Yes	Yes	Yes			Yes	Yes	Yes	Yes	F-33205	
	Yes	Yes	Yes	Yes	Yes	Yes							F-33218	
Yes	Yes	Yes		Yes	Yes			Yes					F-33276	
	Yes	Yes	Yes	Yes	Yes	Yes		Yes					F-33289	
	Yes	Yes	Yes	Yes	Yes	Yes		Yes					F-33292	
			Yes			Yes							F-33324	
			Yes			Yes							F-33340	





















Vacuum Cleaner System charts

Hose connection 28









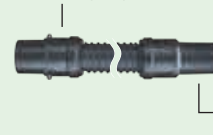

Hose connection 38

Hose connection 32

For Dust Collecting *for Model DVC261, DVC265, DVC660, DVC665 only

Model VC006GM VC007GL 	Model VC002GL VC004GL DVC157L DVC867L 	Model VC3211H VC3211M VC2211M VC3210L VC2510L VC1310L 	Model VC009G VC012G DVC265 DVC265 DVC665 DVC350 	Model DVC750L 	Model VC3012L/M VC4210L/M 	Model VC2012L VC2512L VC3011L 	
Hose 28mm 1.0m *143787-2 without front cuffs 1.5m A-34235 with front cuffs 22, 38 2.5m 195437-5 with front cuffs 22, 24, 38 3.5m 195433-3 with front cuffs 22, 24, 38 5.0m 195436-7 with front cuffs 22, 24, 38 5.0m A-34229 with front cuffs 22, 38 		Hose 38mm with front cuffs 38 1.5 198757-6 2.5 195434-1 5.0 195435-9 		32-B Hose 32mm 4m P-84084 		32-B Hose 32mm 3.5m P-81739 	
Front cuffs Front cuffs 38 195545-2 Front cuffs 22 195547-8 		Front cuffs 24 195546-0 		Joint 22-38 195548-6 		Front cuffs 24 195546-0 	
Tool adaptor Quicksystem ø24 (set) P-70378 Quicksystem ø38 (set) W107418688 		Tool adaptor 		Attachments 			
 Auto-start Wireless System			Wireless unit adapter 		WUT02 Converts tool-triggered AC vacuum cleaners in the market into AWS-compatible vacuum cleaners 		

Front cuffs, Joint & Hose Connection

Hose 28mm Supplied with both Front cuffs 22 and 38 	Rear cuffs (free) 	Front cuffs 38: Inner dia. 38.0mm, Outer dia. 44.2mm Front cuffs 22: Inner dia. 22.4mm, Outer dia. 25.0mm
Hose 38mm 	Rear cuffs (free) 	Front cuffs 38: Inner dia. 38.0mm, Outer dia. 44.2mm
Front cuffs 38, Front cuffs 22 and Front cuffs 24 connection Hose 28 with Front cuffs 22  Hose 28 with Front cuffs 38  Hose 38 with Front cuffs 38  + Front cuffs 24  →		
Hose to hose connection Hose 28 with Front cuffs 38  Hose 38 with Front cuffs 38  →		
Joint 22-38 connection & size Hose with with Front cuffs 38  + Joint 22-38  →		
Size: Inner dia. 22.4mm, Outer dia. 25.0mm		

A



W/ Ø28mm Hose

Model
 VC002GL / VC004GL VC3211H / VC011G / VC012G DVC350
 DVC157L / DVC867L VC3211M
 VC2510L / VC1310L VC2211M / VC3210L DVC660 / DVC665
 DVC261 / DVC265

W/ Front cuffs



38 24 22

B



W/ Ø38mm Hose

Model
 VC001GL / VC003GL VC005GL / DVC155L
 DVC156L / DVC860L DVC861L / DVC865L
 DVC866L / DVC750L

W/ Joint 22-38



C



W/ Ø32mm Hose

Model
 VC2012L / VC2512L VC3011L / VC2000L

W/ Tool adapter 24 **Adapter 38 (option)**



P-81745 P-70421

D



W/ Ø32mm Hose

Model
 VC3012M / VC3012L VC4010M / VC4010L

W/ Tool adapter



P-70378 W107418688

Demolition hammer & Rotary hammer



A B

Front cuffs 22 or 38



C D

Tool adapter 24





A B

Front cuffs 22



C D

Tool adapter 24



*grip base for dust cup is also necessary

	Model	Operation mode	Vacuum attachment set		Cuffs size
			Type	Parts No.	
Electric breaker	HM1501, HM1502, HM1511, HM1512	-	W/o Hose	191M21-2 **191M23-8	Hose 28 without cuffs
			W/ Hose	191M20-4 **191M22-0	Cuffs 24 or cuffs 38
Demolition hammer	HM004G, HM1306, HM1307C/CB, HM1317C/CB, HM1802, HM1812	-	W/o Hose	197168-2 **197170-5	Hose 28 without cuffs
			W/ Hose	197148-8 **197172-1	Cuffs 24 or cuffs 38
Demolition hammer	HM001G, HM002G, HM0830, HM0870C, HM0871C, HM1101C, HM1111C, HM1201, HM1203C, HM1205C, HM1213C, HM1214C	-	W/o Hose	199143-4 **199017-9	Hose 28 without cuffs
			W/ Hose	199142-6 **199014-5	Cuffs 24 or cuffs 38
Rotary hammer	DHR400, HR005G, HR4013C, HR4003C	Drilling / Hammer	-	197148-8 **197172-1	Cuffs 22
	HR5212C, HR5202C	Drilling / Hammer	-	196858-4	Cuffs 22
	HR006G	Drilling / Hammer	-	191N81-0 **191N82-8	Cuffs 22
	HR4002, HR4501C, HR4510C, HR4511C,	Drilling / Hammer	-	196074-8	Hose 28 without cuffs
	HR5212C, HR5202C, HR4002, HR4501C, HR4510C, HR4511C, HR4041C, HR4030C, HR4013C, HR4003C, HR3541C, DHR400, HR005G, HR006G	Hammer	W/ Hose	199144-2 **199019-5	Hose 28 without cuffs
			W/o Hose	199143-4 **199017-9	Hose 28 without cuffs
	HR2670	Chipping / chiseling	-	1914L9-2	Cuffs 22
HR2670FT	Chipping / chiseling	-	1914M0-7	Cuffs 22	

	Model	Operation mode	Vacuum attachment set		Cuffs size
			Type	Parts No.	
Rotary hammer	All Rotary hammer	Drilling	Dust cup set	1914X3-8	Cuffs 22 + 24
	HR140D, HR166D, DHR164, DHR165, DHR171, DHR182, DHR202, DHR262, DHR263, DHR264, HR1840, HR2230, HR2470/F/T/FT, HR2475, HR2800, HR2810/T, HR2811F/FT	Drilling	Dust collector set	193472-7	Cuffs 22
	*DHR164, *DHR165, *HR166D, *DHR171, *DHR182, *DHR202, *DHR241, *DHR262, DHR263, *HR1840, *HR1841F, *HR2230, HR2470/F, HR2475, HR2800, HR2810, HR2811F	All	Dust cup set	198362-9 198376-8 (EU)	Cuffs 22
	DHR242, DHR280, DHR282, HR001G, HR003G, HR2300, HR2600, HR2601, HR2601F, HR2630, HR2631F, HR2641, HR2651, HR2652, HR2653, HR2663, HR3001C, HR3011F, HR007G	All	Dust cup set	195173-3	Cuffs 22
	DHR243, DHR281, DHR283, HR002G, HR004G, HR2320T, HR2630T, HR2631FT, HR2653T, HR3012F	All	Dust cup set	195179-1	Cuffs 22
	DHR183, HR010G	Drilling	Dust cup set	1911P8-4	Cuffs 22
	HR010G	Chipping / chiseling	Bellows B	**413N62-7	Cuffs 22
	HR2670	Drilling	Dust cup set	1914L7-6	Cuffs 22
	HR2670FT	Drilling	Dust cup set	1914L8-4	Cuffs 22

**Simply by replacing the drilling bellows (195179-1) with Bellows B

Circular saw and Plunge Cut Circular Saw

*Inner flange is also necessary.
**with shortlever

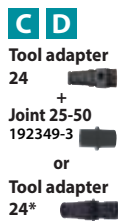
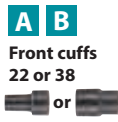

* not needed
Front cuffs 24

Model	Dustnozzleset and Jointset		Cuffs size
	Description	Parts No.	
DHS630	Dust nozzle set	194314-8	Cuffs 22
DHS631	Dust nozzle set	196995-4	Cuffs 22
DHS660, DHS661	Dust nozzle set	199230-9	Cuffs 24
HS012G, DHS680	Dust nozzle set	196961-1	Cuffs 24
DHS710, DHS780, DHS781, DHS782, DHS783, HS003G, HS004G, HS7010, HS7601, HS7610, HS7611, HS6601	Dust nozzle set	196520-1	Cuffs 24
DHS711	Dust nozzle set	198933-2/196520-1	Cuffs 24
HS009G, HS010G, HS011G	-	-	Cuffs 24
HS013G	Dust nozzle set	450316-7	Cuffs 38
DHS900, DHS901, DSP600, DSP601	-	-	Cuffs 24
DSS501	Dust nozzle set	194415-2	Cuffs 22
DSS611	Dust nozzle set	199460-2	Cuffs 22
RS001G	-	-	Cuffs 24
RS002G	-	-	Cuffs 38
5007NB	Dust nozzle set	199711-3	Cuffs 24
5007MGA, 5007MG	Dust nozzle set	199716-3/199968-6	Cuffs 24
5007N, 5007NF	Dust nozzle set	199712-1	Cuffs 24
5008MG, 5008MGA	Dust nozzle set	194489-3/1915M2-9	Cuffs 38
5103R	Joint! (W/O screw) / Joint set (W / screw x2)	415426-7/192419-8	Cuffs 38
5104, 5104S	Joint set	199427-0	Cuffs 38
5143R	Joint	192490-2	Cuffs 38
NS900B, 5902B	Joint set	193068-4/193823-4	Cuffs 38
5903R	Joint set	192419-8	Cuffs 38
HS301D/ HS300D	Dust nozzle set	195334-5	Cuffs 22
HS0600	Dust nozzle set	198263-1 / 198265-7	Cuffs 24
HS6100, HS6101	Dust nozzle set	195801-0	Cuffs 24
HS6600	Dust nozzle set	198933-2 / 196520-1	Cuffs 24
HS7000	Dust nozzle set	197221-4 / 196520-1	Cuffs 24
HS7100, HS7101	Dust nozzle set	195801-0	Cuffs 24
HS7600	Dust nozzle set	197221-4 / 196520-1	Cuffs 24
HS7010, HS7610, HS7611	Dust nozzle set	198933-2	Cuffs 24
SP6000, SP001G	-	-	Cuffs 24

Angle grinder to diamond wheel

*Inner flange is also necessary.

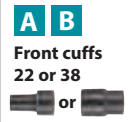
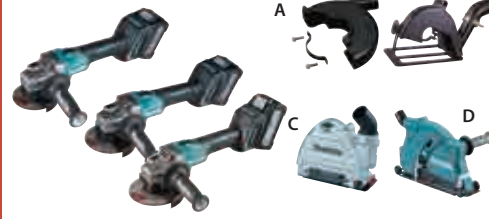





















Model	Dust collection wheel guard for diamond wheel		Cuffs size
	Wheel guard type	Parts No.	
100mm Triple notches bearing box models	A	198414-6	Cuffs 22
	C	199294-3	Cuffs 38
100mm Single notch bearing box models	A	198413-8	Cuffs 22
	C	199295-1	Cuffs 38
9500NB, N9500N	C + Rubber sleeve	192212-0 + 192202-3	Cuffs 22
125mm Triple notches bearing box models	A	198416-2	Cuffs 22
	C	196845-3	Cuffs 38
	A	198415-4	Cuffs 38
125mm Single notch bearing box models	B	192968-5/192972-4	Cuffs 38
	C	196846-1	Cuffs 38
125mm X-Lock models	C	191G05-4	Cuffs 38
125mm Toolless wheel cover (Slide lever style) models	C	191G06-2	Cuffs 38
180mm Triple notches bearing box without brake models	D	*198514-2	Cuffs 38
180mm Twin notches bearing box models & Single notch bearing box models	B	194303-3	Cuffs 38
230mm Triple notches bearing box without brake models	D	198379-2 (M14 spindle) 198440-5 (EU) 198509-5 (5/8" spindle) 198510-0 (M16 spindle)	Cuffs 38
230mm Twin notches bearing box models & Single notch bearing box models	B	194044-1	Cuffs 38
230mm Single notch bearing box models	D	198380-7 (M14 spindle) 198511-8 (5/8" spindle) *198380-7 (M16 spindle)	Cuffs 38
	B	194044-1	Cuffs 38

Angle grinder to cup diamond wheel

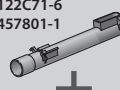

Model	Dust collection wheel guard for cup diamond wheel		Cuffs size
	Wheel size	Parts No.	
125mm Toolless wheel cover 5 notches bearing box models	125mm	191W05-0	Cuffs 38
125mm Triple notches bearing box models	125mm	191W06-8	Cuffs 38
125mm Single notch bearing box models	125mm	195236-5 195237-3 195250-1	Cuffs 38
180mm / 230mm Triple notches bearing box models	180mm	195384-0 195385-8 197584-8 191X44-6 1911K1-3	Cuffs 38
180mm / 230mm Twin notches bearing box models	180mm	195387-4 195388-2	Cuffs 38

For Model	Suction Systems and Part No.
Belt Sander BO001CG, BO002CG, BO003CG, BO004CG, BO005CG, BO006CG BO007CG	Front cuffs 22 413Y47-9 
Direct connection to hose 28	
Finishing Sander DBO380, DBO381, DBO382, DBO480, DBO481, DBO482, DBO484, 9046, BO3710, BO3711, BO4900/V, BO4901 BO4555, BO4556, BO4565, BO4566, BO4557, BO4558	 A Front cuffs 22 
Random Orbit Sander BO5030, BO5031, BO5040, BO5041, BO6030, DBO180	 B Front cuffs 22-38 195548-6 
Belt Sander DBS180, 9032 (Use with Dust cover set 191N60-1)	Dust nozzle assembly 122652-8 
Belt Sander BS001G 9404, 9902, 9903, 9910, 9911, 9920,	 C Tool adapter 24 + Joint 25 192349-3 or Tool adapter 24* 
Random Orbit Sander BO6050	 D Tool adapter 38 + Joint 22-38 195548-6 or Tool adapter 24* 
Cordless Drywall Sander DSL801	Front cuffs24 195546-0 
* not needed Front cuffs 24	













For Model	Suction Systems and Part No.
Jig Saw JV183D, 4326, 4327, 4328, 4329 JV0600	
Cordless Jig Saw DJV180	Dust Nozzle 417853-4 
Jig Saw 4350T/CT/FCT, 4351T/CT/FCT	 A Front cuffs 22 
Cordless Jig Saw DJV181, DJV182 DJV184, DJV185 JV001G, JV002G JV102D, JV103D	Dust nozzle assembly 126331-0 413F05-1 122C71-6 457801-1  + Front cuffs 24 195546-0 
Cordless Multi Tool DTM52, TM001G DTM51 DTM50	Dust attachment set 191R02-6 199627-2 199621-4 
Multi Tool TM30D TM3000C TM3010C	 A Front cuffs 22-38 195548-6 
Cordless Metal Cutter DCS553 Do not use the vacuum cleaner for metal cutting.	Dust cap assembly 127482-2 
Cordless Compact Cut Off DMC300	Dust collect cover attachment 122C54-6 
* not needed Front cuffs 24	



System charts

For Model	Suction Systems and Part No.
Angle Cutter 4114, 4114S 	Elbow joint 32 192613-2 
Dustless Cutter 4100KB 	
Cordless Dustless Cutter DCC500 	
Cordless Dustless Cutter DCC501 	Dust cover set 191N83-6 (with Dust bag) 
Wall Chaser SG1251 	
Concrete Planer PC500C, PC5001C, PC5010C 	
Belt Sander 9031 	Hose set 19-2.5 192108-5 
Belt Sander 9924DB 	Joint 32 192518-6 
Belt Sander 9403 	Joint 32 192349-3 
Wheel Sander 9741 	Joint 410899-9 













- A** Front cuffs 38 
- B** 
- C** Front cuffs 38 
- D** Tool adapter 38 

For Model	Suction Systems and Part No.
Cordless Slide Compound Miter Saw DLS713, DLS714 	
Slide Compound Saw LS0714/F/FL/L, LS0815F/FL, LS1017L, LS1018/L, LS0816F, LS1110F 	
Miter Saw LS1030N 	
Miter Saw LS1440 	
Compound Miter Saw LS1040/F, LS1045 	
Compound Miter Saw LS1221 	
Cordless Compound Miter Saw DLS600 	
Flip Over Saw LF1000 	
Table Top Miter Saw LH1040/F, LH1201FL 	
Slide Compound Saw LS1019/L, LS1219/L 	Front cuffs 24 195546-0 
Cordless Slide Compound Miter Saw LS002G, LS003G, LS004G, DLS110, DLS111, DLS112, DLS211, DLS212 	

- A** Front cuffs 38* 
- B** 
- C** Front cuffs 38 
- D** Tool adapter 38 

*Except model:
 VC008G / VC009G
 DVC660 / DVC665
 DVC261 / DVC265

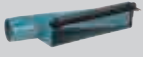

For Model	Suction Systems and Part No.
Table Saw 2704N, 2704 	Joint 419093-0 
Table Saw 2703 	Joint 55 192799-2 
Table Saw MLT100N 	Dust port JM2700090 
Table Saw 2712 	
Band Saw LB1200F 	Joint 419093-0 
Scroll saw SJ401 	Rubber sleeve 36-38 A-30617 
Planer 2012NB 	Hood set 193036-7 Outer dia. 76 mm 

*Except model:
VC008G / VC009G
DVC660 / DVC665
DVC261 / DVC265
DVC350

A
Front cuffs
38*













B

C
Front cuffs
38

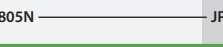

D
Tool adapter
38

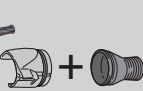

For Model	Suction Systems and Part No.
Power Planer KP001G, DKP181, KP0810/C 	
Power Planer DKP180, KP0800 	Nozzle 451329-1 
1805N 	JPA122277 
Power Planer 1100 	Chip cover 415452-6 
Power Planer 1911B 	Nozzle for vacuum cleaner 192082-7 
Power Planer KP0800, 1804N, 1805N, KP312/S 	

*DVC350
Cannot be used
with Planer models

A
Front cuffs
38*



B

C
Front cuffs
38



D
Tool adapter
38





Nozzle assembly



Model No.	Part No.
N1900B	191569-6
N1923B	152464-5
KP0800, DKP180	451329-1
1804N	JPA122278 (122278-6)
1805N	JPA122277 (122277-8)
KP312/S	193733-5













Joint













*Elbow

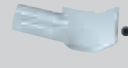

Model No.	Part No.
DKP180, DKP181, KP0810/C, KP0800	*191C20-4
1804N, 1805N, 1806B, KP312/S	181575-9

System charts

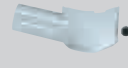
For Model	Suction Systems and Part No.
Plate Joiner PJ7000, DPJ180 	<div style="border: 1px solid black; padding: 5px; margin-bottom: 10px;"> A Front cuffs 22*  </div> <p>*DVC350 Cannot be used with Router models</p> <div style="border: 1px solid black; padding: 5px; margin-bottom: 10px;"> B Front cuffs 22-38  </div> <div style="border: 1px solid black; padding: 5px; margin-bottom: 10px;"> C Tool adapter 24 +  Joint 25 192349-3  </div> <div style="border: 1px solid black; padding: 5px;"> D Tool adapter 38 +  Joint 22-38 195548-6  </div>
Cut-out Tool 3706 	
Dust collection cover 193449-2 	
Cordless Cut-out Tool DCO181, DCO180 	
Cordless Drywall saw DSD180, SD100D 	
Router RP1111C, RP1110C, RP0910 	

For Model	Suction Systems and Part No.
Cordless Router RP001G 	Dust nozzle 194934-8 
Router RP1802/ F, RP1803/ F, RP1801/ F, RP1800/ F, RP2302FC, RP2303FC, RP2301FC, RP2300FC 3612C 	192035-6 
Router RD1101, RF1101, RP1101 	Dust nozzle 193379-7 
Router RP0900, **RT0700C, **RT0701C, **RT0702C 	Dust nozzle 194733-8 
Cordless Router **RT001G, **DRT50 	** Use with Plunge base assembly 
Trimmer RT0700C, RT0701C, RT0702C 	Dust nozzle 195559-1 
Cordless Trimmer RT001G, DRT50 	







































Makita recommend to use 38mm hose when you use Router



For Cleaning

*for Model DVC261, DVC265, DVC660, DVC665, VC008G, VC009G, VC011G, VC012G only

Color

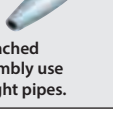
Model	Model	Model	
VC006GM VC007GL VC001GL VC003GL VC005GL DVC155L DVC156L DVC860L DVC861L DVC865L DVC866L		VC3211H VC3211M VC2211M VC3210L VC2510L VC1310L	
Hose 38mm with front sleeve (front cuffs 32A) 1.5m 199388-4		Hose 32mm with front sleeve 1.0m*199453-9 1.7m 199493-7	
Hose 28mm 1.0m *143787-2 1.5m 144408-9 1.5m 152992-0 2.5m 195437-5 3.5m 195433-3 5.0m 195436-7 5.0m A-34229		Bending pipe & Telescopic pipe set without sleeve Aluminum pipe 191B15-1 Plastic pipe 191G89-2	
Bending pipe assembly with pipe lock without sleeve 140G26-3 (front cuffs 32A)		Bending pipe assembly with pipe lock with sleeve 127093-3	
Bending pipe assembly without sleeve 458184-2 (front cuffs 32A)		Bending pipe assembly with sleeve 126756-8	
Cyclone attachment set with pipe lock* ○ 191D71-3 / 191D70-5 ● 191D73-9 / 191D72-1		Cyclone attachment set* ○ 199491-1 / 191D74-7 ● 191D75-5 / 199553-5	
Straight pipe with pipe lock Aluminum Telescopic pipe 28L (L=590-942mm) 199633-7 Bending pipe assembly with pipe lock (140G26-3) set 191B15-1 Plastic Telescopic pipe 28L (L=590-950mm) 127605-2 Plastic straight pipe 28L with pipe lock (L=479mm) ○ 459353-8 ● 459356-2 ● 458942-6		Straight pipe Plastic Telescopic pipe 28 (L=500-850mm) 198560-5 Plastic straight pipe 28 (L=465mm) ● 451424-7 ○ 451241-5 ● 451244-9 ● 456587-4	
Plastic straight pipe 28L with pipe lock (L=340mm) for Cyclone attachment set ○ 191D76-3 ● 191D77-1		Aluminum Telescopic pipe (L=591-43mm) 191X62-4 for others vacuum cleaner nozzles 32mm (1-1/4")	
Aluminum joint pipe (L=465mm) 199844-4 Aluminum straight pipe 32 (L=465mm) 199843-6 for others vacuum cleaner nozzles 32mm (1-1/4")		Tapered nozzle set 192236-6 F/C switching t-nozzle 32 1912F9-8 Rotary brush nozzle set 32 1914Y7-7	
28mm Tip attachments Rotary brush nozzle set 28 Carpet 1914Y6-9		F/C switching t-nozzle 28 Flooring & carpet ○ 198183-9 ● 199431-9	
Nozzle assembly Flat type 199454-7		Nozzle assembly Floor t-nozzle 28 ● 123485-4 ○ 123486-2 ● 123488-8 ● 123539-7	
F/C switching t-nozzle 28 Flooring & carpet 191G86-8		Floor/carpet t-nozzle For rug / carpet ● 198149-9 ○ 198528-1 ● 198527-3 ● 198529-9	
Nozzle assembly Floor t-nozzle 28 ○ 127825-8 ● 127827-4 ● 127828-2		Nozzle assembly For rug / carpet 122291-4	
Nozzle assembly Floor/carpet t-nozzle 28 ○ 191X06-4		Seat nozzle 28 For automobile seat ○ 199038-1 ● 199041-2 ● 199039-9	
Seat nozzle 120 set For automobile seat 140H95-0		Mat nozzle 120 For automobile floor 459056-4	
Brush nozzle set 191M30-1		Sash nozzle ○ 413770-6 ● 413859-0 ● 413809-5	
Long sash nozzle 330 ○ 198919-6 ● 198990-0 ● 198992-6 ● 191D65-8		Crevice nozzle 415 199439-3	
Round brush ● 198552-4 ○ 198878-4 ● 198553-2 ● 198555-8		Shelf brush ● 198537-0 ○ 198873-4 ● 198538-8 ● 198540-1	
Soft brush 360 complete set 140H94-2		Angle attachment set 1914A7-9	
Rubber nozzle 330 set *422437-5 Flexible rubber nozzle 28 *197901-2		*These nozzles cannot be attached directly to Bending pipe assembly use with telescopic pipes or straight pipes.	

System charts

38mm Tip attachments

Hose connection 32

28mm Tip attachments

Model VC006GM VC007GL VC001GL VC003GL VC005GL DVC155L DVC156L DVC860L DVC861L DVC865L DVC866L		Model VC3211H VC3211M VC2211M VC3210L VC2510L VC1310L		Model VC008G VC011G DVC261 DVC660 DVC350	
---	--	--	--	--	--

Cleaning set

- Hose complete 38-2.5
- Straight pipe
- Bending pipe
- Nozzle assembly
- Corner nozzle

195439-1

Hose 38mm

- 1.5m 198757-6
- 2.5m 195434-1
- 5m 195435-9

Bending pipe assembly 38

1912G5-3

Bent pipe 192562-3	Straight pipe 192563-1
------------------------------	----------------------------------

Aluminum Telescopic pipe 38

L=606-958mm
1912G4-5

38mm Tip attachments

Nozzle assembly Flat type (Dry) 199455-5		Universal type (Dry/ Wet) 195551-7		Wide Type (Wet model only) A-47846	
F/C switching t-nozzle 38 Flooring & carpet (Dry) 191G87-6		Compact type A (Dry) 195549-4		Round brush (Dry) 191657-9	
F/C switching t-nozzle Flooring & carpet (Dry) 198184-7 / 198533-8		Compact type B (Wet model only) 195550-9		Corner nozzle (Dry) 410306-2	

Model

VC3012L
VC4210L
VC3012M
VC4210M

Model

VC2012L
VC2512L
VC3011L

Model

DCL184
CL121D

Hose 32mm

4m
P-84084

Hose 32mm

3.5m
P-81739

Curved hand tube inox

P-70346 **A**

Extension tubes

ø35x520mm black 2 pcs
P-72942

Extension tubes

ø35x350mm 3pcs
W107418350 **B**

Floor nozzle

D36x260
(Dry/ Wet)
W107402706

Floor nozzle

D36x300(Dry/ Wet)
P-81789 **C**

Floor nozzle

Universal Type(Wet)
W000014295

Corner nozzle

ø35x300 **D**
W6084

Corner nozzle

ø35x200
Use with P-81745
W000029541

Cleaning set

A, B, C, D set
W107418349

28mm Tip attachments

Flexible rubber nozzle 28

197901-2

Blower nozzle complete

140J64-3

Filter & Dust bag



for Dust
(Powder)

for
Wet & Dry

Compatible with usual Poly bags or
Paper filters, allowing for:

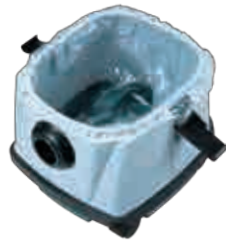

- Quick and easy dust disposal
- Lower-running cost compared with paper dust bag



	VC006GM, VC007GL (Wet & Dry)	VC001GL, VC003GL (Wet & Dry)	VC002GL, VC004GL, VC005GL (Dry)	DVC155L, DVC865L, DVC860L (Wet & Dry)	VC3211H, VC3211M VC3211M, VC2201M (Wet & Dry)	VC3210L, VC2510L (Wet & Dry)	VC1310L (Wet & Dry)	
Use as a set	Powder filter set Dry only *HEPA filter for Dry use only	1911B6-0 *1911B7-8	*191V70-3	*191V70-3	*1917166-6	VC3211H: *196251-2 VC3211M, VC2211M VC2201M: *196252-0	195441-4 *191F82-0	195438-3
	Damper set	1911B4-4	191V68-0	191V68-0	195552-5	196254-6	195552-5	195552-5
	Pre-filter set	1911B5-2	191V69-8	191V69-8	195553-3	196253-8	VC3210L: 195612-3 VC2510L: 195554-1	195553-3
Cloth filter Wet & Dry		144625-1	144625-1 191V71-1 VC005G only	140248-3				
Water filter Wet only It is recommended using water filter when picking up large amount of water repeatedly.	1910N0-0	191V67-2		195555-9 DVC155L, DVC865L, DVC860L only		VC3210L: 195611-5 VC2510L: 195556-7	195555-9	
Dust paper filter (5pcs) for dry powder		10L: A-48430	10L: A-48430	7L: A-49541 10L: A-48430			7L: A-49541	
Filter bag set 10L/15L/25L/35L (5pcs) for dry dust	35L: 1910Y4-9	10L: 1912R3-4 VC001GL, VC002GL, VC005GL, DVC860L, DVC861, DVC865L, DVC866L, DVC867L 15L: 195557-5 VC003GL, VC004GL, DVC155L, DVC156L, DVC157L		15L: 195557-5	25L: 195558-3	25L: 195558-3 VC3210L only 15L: 195557-5 VC2510L only	15L: 195557-5	
Poly bag set (10pcs)	1910R3-2	195432-5	195432-5	195432-5	195440-6	195440-6	195432-5	

To use powder filter, remove the float cage and float by removing the bolts.

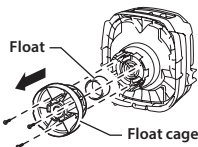

Capacity up tank set

DVC860L, DVC861L, DVC865L, DVC866L, DVC867L
Part No. 191B56-7

"HEPA filter" Mark on tank
DVC861L, DVC863L, DVC864L, DVC866L, DVC867L
Part No. 191B57-5

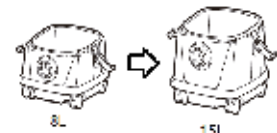

Cordless Cleaner System charts

Color

With pipe lock Model

- CL001G
- CL002G
- CL003G
- DCL283F
- DCL284F
- DCL285F
- DCL286F
- CL114FD
- CL117FD



Model

- DCL180
- DCL181F
- DCL182
- CL183D
- CL106D
- CL107FD
- CL108FD
- CL100D



Model

- CL070D
- CL072D



Cyclone attachment set with pipe lock

- 191D71-3 / 191D70-5
- 191D73-9 / 191D72-1



Dust capsule conv, kit Cyclone unit set

Compatible model:
CL001G, *CL003G, DCL283F,
DCL284F, *DCL286F, DCL180, CL181F
(*Standard Equipment)

- 1910D3-4
- 1910D4-2
- 1910D5-0



Cyclone attachment set

- 199491-1 / 191D74-7(USA)
- 191D75-5 / *199553-5(USA)



*Included sensormatic

Flexible hose set

- 191496-7
- 198868-7
- 198545-1
- 198547-7



Straight pipe with pipe lock

Plastic telescopic pipe 28L with pipe lock

- (L=479-719mm)
Compatible model: CL001G,
CL002G, CL003G, DCL283F,
DCL284F, DCL285F, DCL286F
- 1910Y3-1



Plastic straight pipe 28L with pipe lock

- (L=479mm)
- 458940-0
 - 459353-8
 - 459356-2
 - 458942-6



Plastic straight pipe 28L with pipe lock

- (L=340mm)
for Cyclone attachment set
- 191D76-3
 - 191D77-1

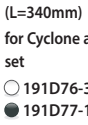

Straight pipe

Plastic Telescopic pipe 28

- (L=500-850mm)
- 198560-5

Plastic straight pipe 28

- (L=465mm)
- 451424-7
 - 451241-5
 - 451244-9
 - 456587-4

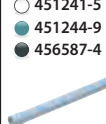

Plastic straight pipe 28

- (L=320mm)
for Cyclone attachment set
- 191D79-7
 - 191D80-2



28mm Tip attachments

Nozzle assembly

Floor t-nozzle 28

- 127825-8
- 127827-4
- 127828-2
- 127826-6



Nozzle assembly

Floor/carpet

- 191X06-4
- 122871-0



Nozzle assembly

Floor t-nozzle 28

- 123485-4
- 123486-2
- 123488-8
- 123539-7



Floor/carpet t-nozzle

For rug / carpet

- 198149-9
- 198528-1
- 198527-3
- 198529-9



Nozzle assembly

For rug / carpet

- 122291-4



Seat nozzle 28

For automobile

- 199038-1
- 199041-2
- 199039-9



Brush nozzle set

- 191M30-1



Seat nozzle 120 set

For automobile
140H95-0



Mat nozzle 120

For automobile
459056-4



Sash nozzle

- 413770-6
- 413859-0
- 413809-5



Long sash nozzle 330

- 198919-6
- 198990-0
- 198992-6
- 191D65-8



Crevice nozzle 415

199439-3



Angle attachment set

1914A7-9



Round brush

- 198552-4
- 198878-4
- 198553-2
- 198555-8



Shelf brush

- 198537-0
- 198873-4
- 198538-8
- 198540-1



Soft brush 360 complete set

140H94-2

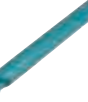

Sash nozzle holder 28

For Plastic straight pipe

Model:

- CL001G, CL002G, 459036-0
- CL003G, DCL283F, 459354-6
- DCL284F, DCL285F, 459355-4
- DCL286F, CL114FD, 459038-6
- CL117FD

Others Model

- 416043-6
- 451242-3
- 451245-7
- 456585-8

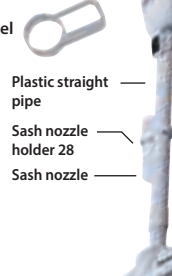

Rubber nozzle 330 set

- 422437-5



*These nozzles cannot be attached directly to Bending pipe assembly use with telescopic pipes or straight pipes.

Holder set

Part No. 199971-7

Model: CL001G, CL002G, DCL283F,
DCL284F, DCL285F, DCL180,
DCL180F, DCL181F, DCL182,
DCL182F, CL114FD,
CL107FD, CL072D

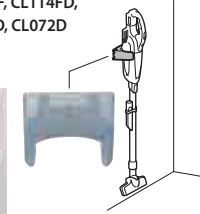

Cleaner stand set

Part No. 1911L1-0

For holding Makita cordless cleaner in an upright position.

Model: CL001G, CL002G,
CL003G, CL070D, CL100D,
CL102D, CL106FD, CL107FD,
CL108FD, CL111D, CL114FD,
CL117FD, CL183D, DCL180,
DCL181F, DCL182,
DCL283F, DCL284F,
DCL285F, DCL286F



Cordless Cleaner and Backpack Vacuum Cleaner for selectable filters & Carrying bag

Capsule type cleaner Model: CL001G, DCL283F, DCL284F, DCL181F, DCL180F, DCL180, CL183D, CL108FD, CL106FD, CL070D

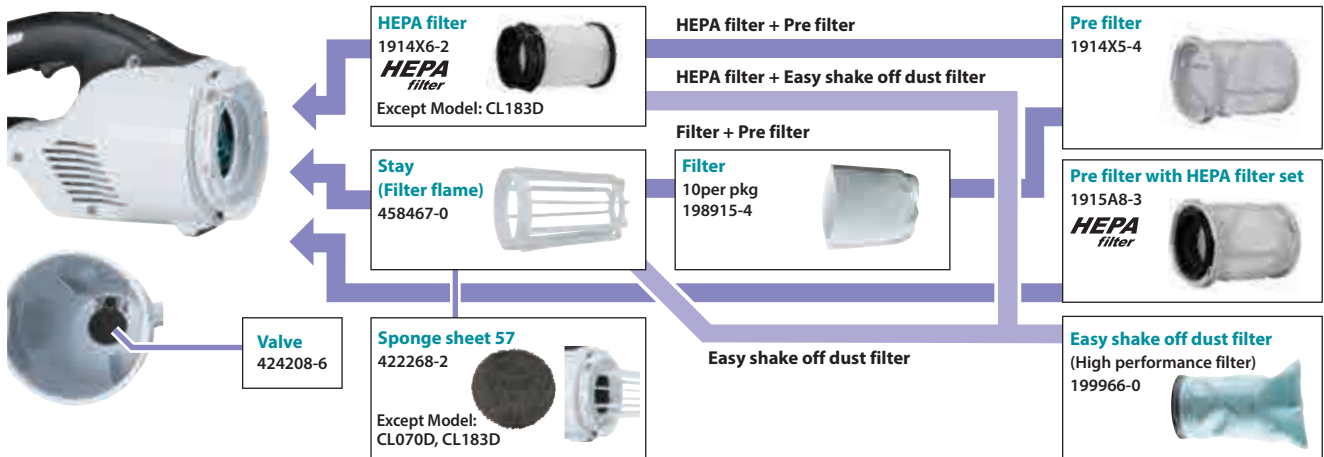

Paper bag type cleaner Model: CL002G, DCL285F, DCL182, DCL182F, CL114FD, CL121D, CL107FD, CL072D, DCL184, CL121D

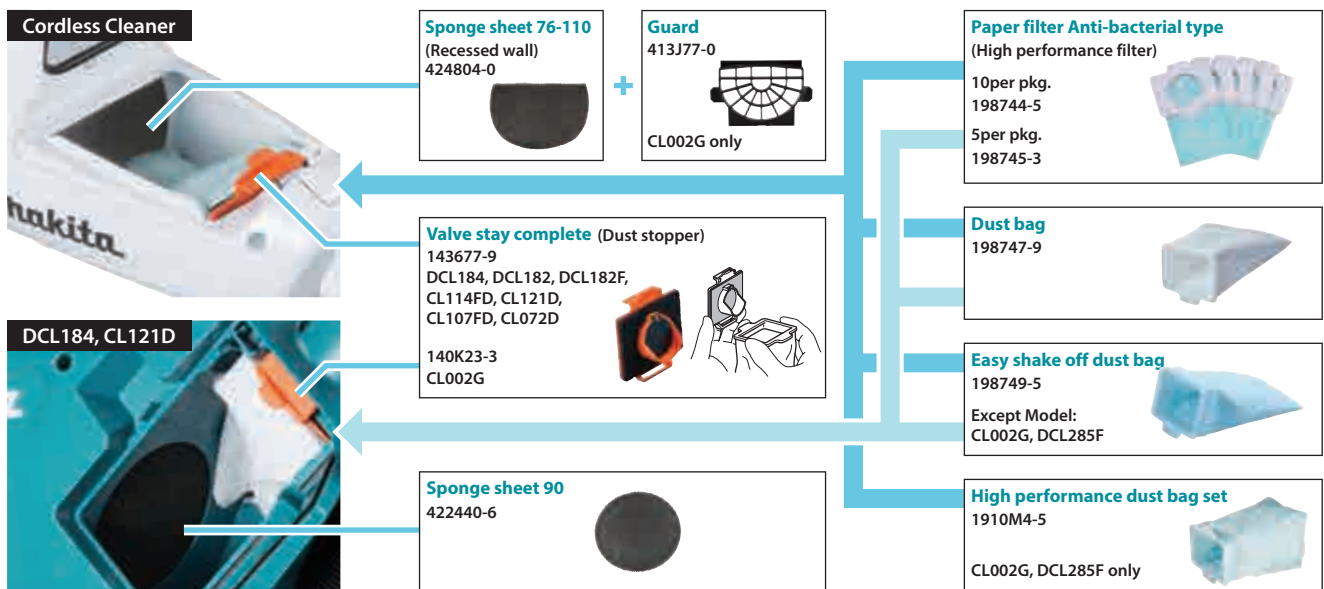

New cyclone unit Model: CL001G, CL003G, DCL283F, DCL284F, DCL286F

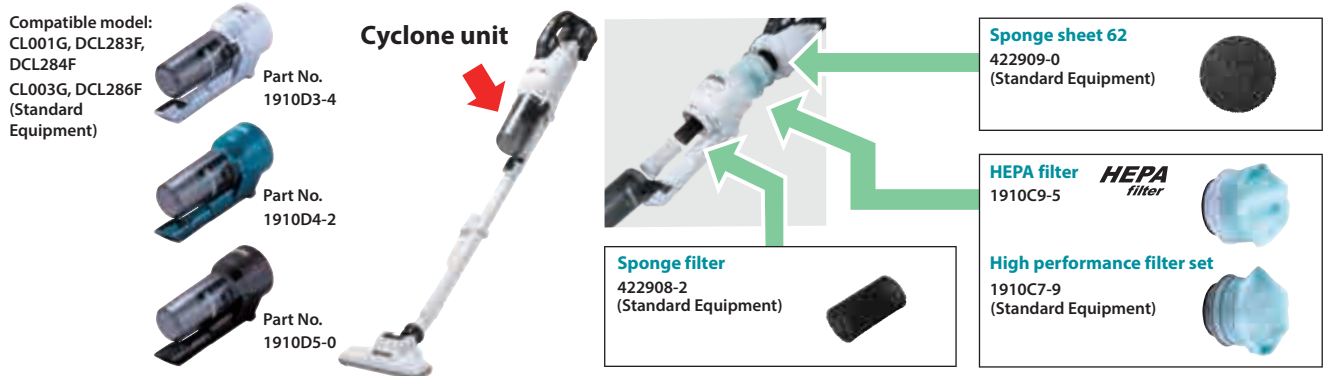

Cleaner carrying bag

Cleaner body, battery, charger and accessories can be stored together.



Except Model: CL003G, DCL286F, DCL184, CL121D (LxWxH: 600x210x190mm) Part No. 199901-8 with shoulder belt/ Part No. 161904-2



Model: DCL184, CL121D (LxWxH: 490x210x230mm) Part No. 199900-0 with shoulder belt: Part No. 162544-9



Cordless Upright Cleaner and Portable Vacuum Cleaner for filter and accessories



Cordless Upright Cleaner Model: DVC560, VC010G

28mm Tip attachments

Seat nozzle 28
For automobile
199038-1
199041-2
199039-9

Long sash nozzle 330
198919-6
198990-0
198992-6
191D65-8

Seat nozzle 120 set
For automobile
140H95-0

Crevice nozzle 415
199439-3

Mat nozzle 120
For automobile
459056-4

Round brush
198552-4
198878-4
198553-2
198555-8
191D67-4

Brush nozzle set
191M30-1

Shelf brush
198537-0
198873-4
198538-8
198540-1

Sash nozzle
413769-1
413770-6
413859-0
413809-5

Soft brush 360 complete set
140H94-2

Grip assembly set
Dusts can be thrown away by removing Dust case of Cyclone attachment.
1912B1-6

Filter bag set
10pcs. set
191Y96-3

Dust bag set
191Y86-6

Main filter h set
191E39-5
HEPA filter

Brush complete set
DVC560: 1910T8-6
VC010G: 1914B1-8

Cordless Portable Vacuum Cleaner Model: DVC750L

For Cleaning
Hose Complete
28-2.0m with Front cuffs 38
140G04-3

38mm Tip attachments

Wide Nozzle
458891-7

Sash Nozzle
458919-1

Round brush
191657-9

Corner nozzle
410306-2

Joint 22-38
195548-6

Tapered nozzle set
192236-6

Joint 38
418500-0

28mm Tip attachments

Dry only

Filter complete (HEPA filter)
Dry 162518-0
HEPA filter

Pre filter and Damper set
Dry only 199827-4

Damper
422449-8

Pre filter
162635-6

Wet only

Wet filter set
191M39-3

Shoulder Belt Set
199486-4

Backpack Vacuum Cleaner for selectable filters & Carrying bag and Robotic Cleaner

Backpack Vacuum Cleaner Model: VC008G, VC011G, VC012G, VC009G, DVC660, DVC665, DVC261, DVC265

VC011G, VC012G, DVC660, DVC665



- Dust bag assembly**
191C30-1
- Filter bag set (Paper dust bag)**
10per pkg.
191C26-2
- Main filter H set (HEPA filter)**
191D12-9 **HEPA filter**

VC008G, VC009G, DVC261, DVC265



- Dust bag assembly**
197898-5
197899-3(EU)
- Filter bag set (Paper dust bag)**
10per pkg.
197903-8
- Filter set assembly (HEPA filter)**
191Y27-2(VC008G, VC009G)
127725-2(DVC261, DVC265)

Harness cover set
Washable harness cover made of a mesh material for improved breathability
VC008G, VC009G, VC011G, VC012G, DVC660, DVC665 DVC261, DVC265
191Y14-1



Protection cover set
When using Backpack vacuum cleaner in tight spaces etc., Protection cover is very helpful to prevent the scratches on surrounding objects caused by hitting cleaner.



DVC261, DVC265
191054-7

VC008G, VC009G
1911W4-1
1914H7-8*
*For B0001CG series with Battery case



Robotic Cleaner Model: DRC200, DRC300

DRC200



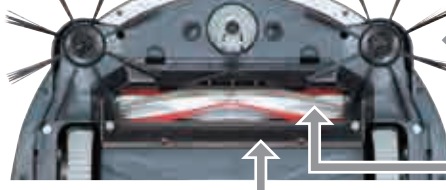

- Side brushes**
SH00000321 (Soft)
SH00000065 (Standard)
- Power brush**
SH00000320 (Soft)
SH00000063 (Standard)
SH00000319 (Combination)
- Boundary line tape (15m roll)**
SH00000231(EU)
SH00000240 (USA, AU)
- Turn brush cover**
SH00000064
- Filter**
SH00000213

DRC300

- Side brush assembly set**
191P26-0 (Soft) for tatami mats, etc.
191P28-6 (Standard)
- Main brush complete set**
191P20-2 (Soft) for tatami mats, etc.
191P22-8 (Standard)
- Bottom plate assembly set**
191P24-4
- Magnet tape set**
191P18-9
5m long, with double-sided tape
- Filter H complete set**
191P31-7 **HEPA filter**
- Sponge sheet set**
191X35-7
Sponge part to be attached to Bumper for protection of surrounding objects from damage

Cordless Polisher Scrubber and Cordless Vacuum Sweeper for accessories

Cordless Polisher Scrubber Model: PS001G

Brush 190

Brush bristle type: Soft
Application: For cleaning wooden floors, decks, etc.

1914T0-6



Brush bristle type: Medium
Application: For cleaning general interior floors.

1914T1-4



Brush bristle type: Hard
Application: For cleaning exterior concrete floors and removing grease stains from kitchens and similar areas.

1914T2-2



Brush bristle type: Hard (with abrasive)
Application: For cleaning porcelain tiles and similar surfaces.

1914T3-0



Floor pad

	Cleaning ability*2	Cleaning surface	Application
Color*1: White 1914S5-9	Low	Smooth	For surface polishing of resin wax.
Color*1: Red 1914S6-7			
Color*1: Blue 1914S7-5	High	Rough	For cleaning of resin wax.
Color*1: Brown 1914S8-3			
Color*1: Black 1914S9-1			For removing resin wax.

*1 The brighter and lighter the color, the finer the grit; the darker and deeper the color, the coarser the grit (industry standard).

*2 Stain and wax removal power



Pad holder 175 set

Pad holder for Floor pad 200 (used with Floor pad 200)
Attachment portion for the floor pad: hook and loop fastener

1914S4-1

Pad holder 175 set

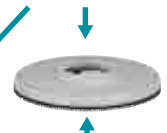

Floor pad

Various pads can be attached to the hook-and-loop side.

Accessory bag set

An accessory bag made of water-resistant materials for carrying wet accessories. Capable of storing all accessories for this model.

1915D1-8



Cordless Vacuum Sweeper Model: VS001G

Multi adapter set

- MAKPAC (all types) can be installed, which is also convenient for storing cleaning accessories.
- Portable power pack PDC01 /1200 /1500 can be installed to improve run time.

1913F5-2



Dust bag set

- Capacity: 47L (12.4 gal)
- Dust bag suitable for collecting waste such as fallen leaves.
- Dust bag can be reused.

1913F7-8



Vacuum connector

Still photo	Name	Related models	Part No.
	Joint A32 set	Adapter for connecting Straight Pipe 28 to a third-party vacuum cleaner nozzle	PACVAC SHOPVAC Proteam 191M77-5
	Joint B35 set		KARCHER Nilfisk 191M78-3
	Joint C38 set		Proteam Side Winder 191M79-1
	Front cuff 38 set	Attached to hose 28, for model that require Cuff 38	195545-2
	Front cuff 22 set	Attached to hose 28, for model that require Cuff 22	195547-8
	Joint 22-38 set	Attached to cuff 38, for model that require Cuff 22	195548-6
	Front cuff 24 set	Attached to cuff 22 or 38, for model that require Cuff 24	195546-0
	Holder cuff set	Front cuff 22, Front cuff 24 and Holder 10-33 set	195637-7
	Tool adapter with regulation	VC2012L, VC2512L, VC3011L	P-81745
	Tool adaptor 22 quick set	VC2000L, VC2012L, VC2512L, VC3011L	W107418661
	adapter 35/38	VC3012L/M, VC4210L/M, VC2012L, VC2512L, VC3011L	P-70421
	Tool adaptor 38	VC2012L, VC2512L, VC3011L	W107418680
	Quicksystem ø24 (set)	VC3012L/M, VC4210L/M	P-70378
	Quicksystem ø38 (set)		W107418688
	Tool cuff adapter 24		P-70415
	Tool cuff adapter 38		P-70421

Filter & bag

Name	Per pkg.	Related models	Part No.
Fleece filter bag (Filter bag)	5	VC2000L, VC2012L, VC3011L, VC2512L,	P-72899
Pre Disposal bag	5		P-70297
PTFE Flat filter	1	VC4210M / L	W107418351
Motor cooling filter PET	1		W107418352
Fleece filter bag (Filter bag)	5		W107418353
Long-Life Filter bag	1		W107418354
Pre Disposal bag	5		W107418355
PET Filcelent	1	VC2512L, VC3011L, VC3012M / L	P-70219
Fleece Filter bags	5	VC2512L, VC3011L, VC3012M / L	P-84078
Pre Disposal bag	5		P-70297

Vacuum kit

Still photo	Name	Related models	Part No.
	Vacuum kit set	DUB363	191P37-5

Dust bag for blower, cleaner

Still photo	Name	Related models	Part No.
	Dust bag assembly	DUB185, DUB186, UB100D, UB101D, UB1102, UB1103	123241-2
	Dust bag set	DUB363	191P40-6
	Dust bag	DUB187	GB00000185

Adapter

Still photo	Name	Related models	Reference	Part No.
	Adapter pipe 104-72 set	UB002C	104-72	1910M7-9
	Adapter pipe set MG	UB400MP, UB401MP	80-72	191C15-7
	Adapter pipe 71 set	DUB362, DUB363	71	191J13-3
	Adapter pipe 80-72 set	DUB184	80-72	191L13-5
	Adapter pipe 85-72 set	UB001C, UB001G, UB003C	85-72	191L96-5

Nozzle for blower, cleaner

*use with adapter

Still photo	Name	Related models	Description	Part No.
	Nozzle assembly	DUB185, DUB186, UB100D, UB101D, UB1102, UB1103	Length 0.22m	123245-4
	Garden nozzle assembly set		Length 0.54m	191G09-6
	Anchor nozzle set		Use with Nozzle assembly	192236-6
	Flexible hose set		-	191M34-3
	Flexible hose set		Hose length 0.95m	196643-5
	Water blowing nozzle set	DUB184	Width 217mm	1915C8-7
	End nozzle 74 set	UB004C	Diameter 74mm	1914H0-2
	Flat nozzle set	UB004C	-	1914H1-0
	Gutter nozzle set	*DUB184, *DUB362, DUB363, *UB001C, *UB001G	Length 2.9m	191B03-8
	End nozzle 80 set	UB001C, UB001G	Diameter 80mm	191P97-7
	Extension nozzle set	DUB184, DUB362, DUB363, UB001C, UB001G, UB002C, UB003C	DUB184, UB001C, UB002C, UB003C, UB001G: use with Adapter pipe	197888-8
	Flat nozzle set			197889-6
	Long nozzle	DUB362	-	412788-4
	T shape vacuume nozzle assy	DUB187	Dust collection can be efficiently performed on flat ground, etc.	GB00000165

Harness, belt

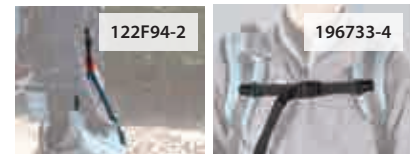











Still photo	Name	Related models	Part No.
	Band assembly	UB003C	122F94-2
	Band 25 set	PM001G	196733-4
	Sholder harness assy	DUB187	GB00000038

Cleaning

Cordless Dust Blower accessories

For model:
AS001G, DAS180

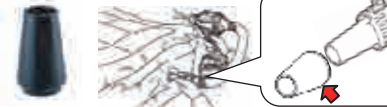
*1 Used by attaching to Nozzle 13 and Air vent hose





Item	Description	Part No.
Nozzle 13 set 	Nozzle diameter: ϕ 13mm Nozzle diameter: ϕ 13mm (Same as the caliber of the machine) • For blow-off works • For inflating large play pools, etc.	191X15-3
Nozzle 7 set 	Nozzle diameter: ϕ 7.0mm For filter cleaning	191X13-7
Nozzle 3 set 	Nozzle diameter: ϕ 3.0mm	191X11-1
Flexible nozzle complete set 	Nozzle diameter: ϕ 6.0x800 (Hose) For blowing dust away from OA equipment or narrow spaces where this machine cannot enter	191X21-8
Wide range nozzle set 	Nozzle diameter: ϕ 6.0mm (each hole) For wide range blow-off	191X19-5
Pinch valve nozzle set 	Nozzle diameter: ϕ 7.0mm For inflating/deflating inner tubes and beach balls	191X17-9
Long nozzle set 	Nozzle diameter: ϕ 8.0mm • For cleaning anchor holes • For cleaning narrow spaces that are out of reach Nozzle 13 set (191X15-3) is also necessary.	191X78-9
Air vent hose complete set 	Nozzle diameter: 13mm (Same as the caliber of the machine) For inflating/deflating inner tubes and beach balls (Remove Dust cap complete from the machine and attach this hose.)	191X23-4
Rubber attachment 20 -30 set 	Nozzle diameter: 7.0mm For deflation large play pools and inflatable beds etc.*1 Air vent hose complete set (191X23-4) and nozzle 13 set (191X15-3) are also necessary.	191X25-0
Rubber attachment 65 set 	Nozzle diameter: ϕ 65mm For deflating futon (bedding) compression bag*1 Air vent hose complete set (191X23-4) and nozzle 13 set (191X15-3) are also necessary.	191X27-6
Filter C complete set 	For use of the machine in a dusty environment (Remove Dust cap complete from the machine and attach this Filter.)	191X29-2

Power washer accessories for DHW080, HW1200, HW1300 & HW001G

Shape	Models	Part No.
	DHW080, HW001G HW1200, HW1300	197842-2
	HW001G	1912Y4-1
	HW001G	1912Y5-9
	HW001G	1912Y6-7
	DHW080, HW001G	191M52-1 (TAIWAN)
	DHW080, HW001G HW1200, HW1300	197822-8
	DHW080, HW001G HW1200, HW1300	191U88-8
	DHW080 HW1200, HW1300	191U86-2
	DHW080, HW001G HW1200, HW1300	191U84-6
	DHW080, HW001G HW1200, HW1300	197876-5
	DHW080, HW001G HW1200, HW1300	197824-4
	DHW080, HW001G HW1200, HW1300	197864-2
	DHW080, HW001G *HW1200, *HW1300 (**for 110-127V)	197859-5
	HW1200 **HW1300 (for 220V-240V)	198909-9
	DHW080, HW001G HW1200, HW1300	197870-7
	DHW080, HW001G HW1200, HW1300	197831-7
	DHW080, HW001G HW1200, HW1300	197828-6
	DHW080, HW001G HW1200, HW1300	1912Y2-5











Shape	Models	Part No.	
	DHW080, HW001G HW1200, HW1300	10m	197837-5
		15m	197840-6
	DHW080, HW001G HW1200, HW1300	5m	197845-6
		8m	197847-2
		10m	197850-3
	DHW080, HW001G HW1200, HW1300	197867-6	
	DHW080, HW001G HW1200, HW1300	197873-1	
	DHW080, HW001G HW1200, HW1300	1910R1-6	
	DHW080, HW001G HW1200, HW1300	1910R2-4	
	DHW080, HW001G HW1200, HW1300	197853-7	
	DHW080, HW001G HW1200, HW1300	122F22-7	
	DHW080, HW001G HW1200, HW1300	197883-8	
	DHW080, HW001G HW1200, HW1300	197879-9	
	DHW080	199486-4	
	DHW080	TR00000002 TR00000001 (EU)	

Cordless Pressure Washer for DHW180

Shape	Part No.
	LX00000001
	LX00000004
	LX00000002
	LX00000003
	LX00000063





Outdoor Power Equipment

Blade selection guide



Blade type / Image				
		Short and soft grass	Tall and hard grass	Bush including tree beginning to grow
Nylon cord		←→		
Plastic blade		←→		
Metal blade		←→		
		←→		
			←→	
Brushcutter blade			←→	
Shredder blade				←→
Chisel blade				←→





Metal blade

Still photo	Related models	Blade diameter (mm)	hole diameter (mm)	Number of teeth	Thickness (mm)	Description	Part No.	
	UR016G, UR017G	230	25.4	2	2	-	197997-3	
	DUR369A, DUR369L, UR006G, UR007G, UR012G, UR013G, UR101C, UR201C	255					197998-1	
		UR012G					305	198345-9
							305	198347-5
	DUR190L, DUR190U, DUR191L, DUR191U	230	25.4	3	3	-	D-66020	
	DUR190L, DUR190U, DUR191L, DUR191U, DUR368A, DUR368L, UR002G, UR003G, UR016G, UR017G					IN KOREA, THIS BLADE CAN BE US	195298-3	
	DUR369A, DUR369L, UR006G, UR007G, UR012G, UR013G, UR101C, UR201C	255				-	195299-1	
	UR012G	305				-	195300-2	
	DUR190L, DUR190U, DUR191L, DUR191U, DUR368A, DUR368L, DUR369A, DUR369L, UR002G, UR003G, UR006G, UR007G, UR016G, UR017G, UR101C, UR201C	230	25.4	4	1.2	-	195150-5	
	DUR190L, DUR190U, DUR191L, DUR191U, DUR368A, DUR368L, DUR369A, DUR369L, UR002G, UR003G, UR006G, UR007G, UR101C, UR201C				1.8		197524-6	
	DUR190L, DUR190U, DUR191L, DUR191U	255			-		D-66008	
	DUR369A, DUR369L, UR006G, UR007G, UR012G, UR013G, UR101C, UR201C				-		197320-2	
	DUR369A, DUR369L, UR006G, UR007G, UR012G, UR013G, UR101C, UR201C				2		196895-8	
	DUR194	200	25.4	8	1.4	-	191Y44-2	

Chisel blade and Protection guard for brushcutter

Chisel blade								Protection guard for brushcutter				
Still photo	Name	Related models	Blade diameter (mm)	Number of teeth	Arbor saiz (mm)	Thickness (mm)	Part No.	Still photo	Name	Related models	Pipe size (mm)	Part No.
	Cutter 225 set MG	DUR369A, UR006G, UR012G, UR013G	225	24	25.4	1.8	199872-9		Protector 225 set MG	UR012G	28	199873-7
										UR013G	25.4	1911Y0-3
										DUR369A, UR006G	25.4	1912L4-0

Shredder blade and Protection guard for brushcutter

Shredder blade							Protection guard for brushcutter				
Still photo	Name	Related models	Blade diameter (mm)	Arbor saiz (mm)	Thickness (mm)	Part No.	Still photo	Name	Related models	Pipe size (mm)	Part No.
	Shredder blade 270 set MG	UR012G, UR013G	270	25.4	3.9	199874-5		Protector set MG	UR012G	28	199875-3
									UR013G	25.4	1911Y1-1

Edger blade

Still photo	Name	Related models	Cutting width (mm)	Part No.
	Blade set	EE400MP, UE001G	2.5	196745-7

Outdoor Power Equipment

Grass trimmer plastic blade

Grass trimmer plastic blade					Replacement plastic blade		
Still photo	Name	Related models	Thread	Part No.	Still photo	per pkg.	Part No.
	Plastic blade 230 set ME	UR100D	M8x1.25RH	198848-3		5	198851-4
	Plastic blade 230 set MG	DUR189, DUR194, DUR368A, DUR368L, UR002G, UR003G	M10x1.25LH	191Y45-0		12	198426-9
	Plastic blade 255 set ME	DUR189, DUR190L, DUR190U, DUR191L, DUR191U, DUR368A, DUR368L, DUR369A, DUR369L, DUR369N, DUX60, UR002G, UR003G, UR006G, UR007G, UR008G, UR016G, UR017G, UR101C, UR201C, UR202C	M8x1.25RH M8x1.25LH M10x1.25LH	198383-1			
	Plastic blade 305 set MG	DUR369A, DUR369L, DUR369N, UR006G, UR007G, UR008G, UR012G, UR013G, UR101C, UR201C, UR202C	M10x1.25LH	199868-0		12	199870-3

String trimmer head

Quick loading Trimmer Head

(UN-74L, UN-72L, 96-M8L/R, 96-M10L, 121-M10L)

Nylon cord can be feded without opening the head

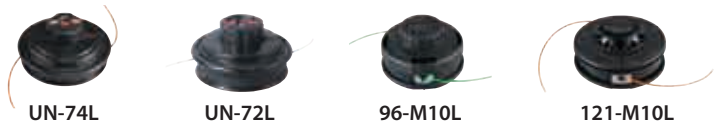

0 85(sec.)



0 35(sec.)



Up to **58%** less feeding time!

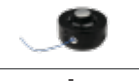

Still photo	Name	Related models	Reference	Size	Thread	Cord/ Line	Part No.
	Trimmer head 121-M10L set	UR012G, UR013G	121-M10L	5"	M10x1.25LH	2.0mm x 2m x2	191Y88-2
		UR008G, UR012G				2.4mm x 2m x2	191D93-3
	Trimmer head 121-M10L set	UR013G	121-M10L	5"	M10x1.25LH	2.7mm x 2m x2	1911Y2-9
		UR014G	121-M10L	5"	Spline 10T	2.7mm x 2m x2	1911Y3-7
	Trimmer head 105-M10L set MG	UR012G, UR013G	Bump & Feed Z5L / 105-M10L	5"	M10x1.25LH	2.7mm x 3m	199884-2
	Cutter assembly 110-M10L set ME	DUR369A, DUR369L, DUR369N, UR006G, UR007G, UR008G, UR101C, UR201C, UR202C	UN-72L / 110-M10L	5"	M10x1.25LH	2.4mm x 6m	198266-5
	Nylon cutting head set	DUR190L, DUR190U, DUR191L, DUR191U, DUR368A, DUR368L, DUR369A, DUR369L, DUR369N, DUX60, EM403MP, UR002G, UR003G, UR006G, UR007G, UR008G, UR101C, UR201C, UR202C	UN-74L	4.4"	M10x1.25LH	2.4mm x 3.6m	196324-1
	Trimmer head assembly 98-M10L	DUR190L, DUR190U, DUR191L, DUR191U, DUR192L, DUR194, DUR368A, DUR368L, DUR369A, DUR369L, DUR369N, UR002G, UR003G, UR006G, UR007G, UR008G, UR016G, UR017G, UR101C, UR201C, UR202C	98-M10L	4"	M8x1.25LH	2.0mm x 3m	1914R8-6
					M10x1.25LH	2.0mm x 3m	1915D8-4
		DUR369A, DUR369L, DUR369N, UR006G, UR007G, UR008G, UR101C, UR201C, UR202C	M10x1.25LH	2.4mm x 3m	1915D7-6		
			M8x1.25LH	2.4mm x 3m	1914R6-0		
	Nylon cutting head assembly set	DUR192L, DUR368A, DUR368L, DUR369A, DUR369L, DUR369N, UR002G, UR003G, UR006G, UR007G, UR008G, UR101C, UR201C, UR202C	Bump & Feed ECO 4L	4" Low profile	M10x1.25LH	2.0mm x 3m	197296-3

Still photo	Name	Related models	Reference	Size	Thread	Cord/ Line	Part No.
	Trimmer head 96-M10L set	DUR190L, DUR190U, DUR191L, DUR191U, DUR192L, DUR194, DUR368A, DUR368L, DUR369A, DUR369L, DUR369N, EM408MP, EM409MP, UR002G, UR003G, UR006G, UR007G, UR008G, UR016G, UR017G, UR101C, UR201C, UR202C	96-M10L	4"	M10x1.25LH	2.0mm x 4m	191D89-4
	Trimmer head 96-M10L set	DUR190L, DUR191L, DUR192L, DUR194, DUR368A, DUR368L, DUR369L, DUR369N, EM405MP, UR002G, UR003G, UR006G, UR007G, UR008G, UR201C					191R00-0
	Trimmer head 96-M10L set	DUR190L, DUR190U, DUR191L, DUR191U, DUR368A, DUR368L, DUR369A, DUR369L, DUR369N, UR002G, UR003G, UR006G, UR007G, UR008G, UR101C, UR201C, UR202C				191D90-9	
	Cutter assembly 95-M10L set M	DUR190L, DUR190U, DUR191L, DUR191U, DUR192L, DUR194, DUR368A, DUR368L, UR002G, UR003G	95-M10L	4"	M10x1.25LH	2.0mm x 3m	198892-0
		DUR190L, DUR190U, DUR191L, DUR191U, DUR192L, DUR194, DUR368A, DUR368L, DUR369A, DUR369L, DUR369N, UR002G, UR003G, UR006G, UR007G, UR008G, UR016G, UR017G, UR101C, UR201C, UR202C					198893-8
	Nylon cutting head assembly 95-M10L set	DUR368A, DUR368L, UR101C, UR201C, UR202C				2.4mm x 3m	197804-0
	Trimmer head 96-M10L set	UR012G					1912N0-2
	Trimmer head 96-M8R set	DUR189	96-M8R	4"	M8x1.25RH	2.0mm x 2m	191D92-5
	Nylon cutting head assembly set		Bump & Feed ECO 4R"	4" Low profile			197297-1
	Nylon cutting head assembly 95-M8R set ME		95-M8R	4"			198971-4
	Spool set	DUR181, UR180D	-	-	-	1.65mm x 8m	195858-1
	Nylon cutting head assembly 75-M8R set ME	UR100D	-	3"	M8x1.25RH	1.65mm x 8m	198854-8
-	-	UR3000	-	-	-	-	DA00000001











Protection guard for brushcutter

Still photo	Name	Related models	Type	Working width (mm)	Pipe size (mm)	Part No.
	Protector U 330 set	UR016G, UR017G	-	-	-	1911X4-8

Line character

Shape	Sharpness	Energy Saving	Quietness
		A	A
	AA		
	A	AA	AA

Color chart

Dia.	Color / Shape	Light duty		Heavy duty	
		Low density	High density	Low density	High density
1.3mm		↔			
1.6mm-1.65mm	 	↔↔			
2.0mm	 		↔↔↔		
2.4mm	  			↔↔↔↔	
2.7mm					↔↔↔↔↔
3.0mm	 				↔↔↔↔↔↔

Four-Leaf Line

Low noise and energy saving

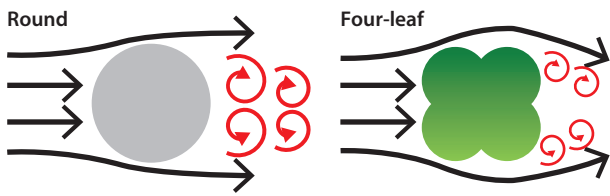

Four-leaf shape makes small vortex and realizes low noise and energy saving feature thanks to less air resistance.

The amount of cutting per 1 charge

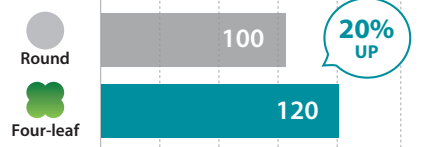

Noise

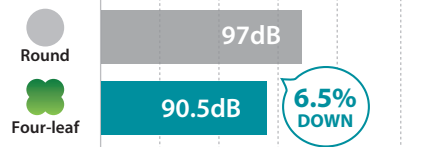

Standard Nylon cord

Color / Shape	Ring (mm)	dia. (mm)	length (m)	Part No.
	Single	1.3	15	E-02727
	Single	1.6	15	E-02733
			126	E-02705
	Single	2.0	15	E-02705
			126	E-02711
			15	E-02749
	Single	2.4	87	E-02761
			262	E-02783
			15	E-02808
	Single	2.4	69	E-02814
			206	E-02820

Four-leaf Spiral Nylon cord

Color / Shape	Ring (mm)	dia. (mm)	length (m)	Part No.
	Single	1.65	15	E-01731
			30	E-01747
			445	E-01753
	Single	2.0	15	E-01769
			30	E-01775
			310	E-01781
	Single	2.4	15	E-01797
			30	E-01806
			225	E-01812
	Single	2.7	15	E-01828
			30	E-01834
			180	E-01840

Double-layer Nylon cord

Increased durability up to 130%* thanks to Flexible core coated with Impact & abrasion resistant skin
*compared to standard nylon cord



Color / Shape	Ring (mm)	dia. (mm)	length (m)	Part No.
	Single	3.0	15	E-02836
			56	E-02842
			168	E-02858
	Single	3.0	15	E-02870
			44	E-02886
			132	E-02892

Other Nylon cord (round, natural)



Size	Part No.
1.65mmx15m	DA00000003
1.65mmx30m	195861-2
2.4mmx5m	B-01971
3.0mmx4m	B-07375

Harness

Still photo	Name	Related models	Type	Part no.
	Band assembly	DUN500W, DUN501W, DUR181, DUR189, DUR190L, DUR191L, DUR368A, DUR368L, DUX60, UR100D, UR180D	Single	125516-5
	Band assembly	DUR190L, DUR190U, DUR191U	Single	125520-4
	Band assembly	DUR189, DUR190L, DUR191L, DUR192L, DUR193, DUR194, DUR368L, DUR369L, DUX18, DUX60, UR003G	Single	127508-0
	Band assembly	DUA200, UN001G, UR016G, UR017G	Single	122D94-0
	Band assembly	DUR369A, UR002G	Comfort	122906-3
	Band assembly	DUR368A, UR002G, UR006G, UR012G, UR013G, UR016G	Comfort	122A37-4
	Band assembly set	DUA250, DUA251, DUA300, DUA301, UA001G, UA002G, UA003G, UA004G	Comfort	191K37-5
	Band assembly set	DUR369A, UR012G	Comfort	196129-9
	Band assembly set	DUR369A, UR006G, UR007G, UR012G, UR013G	Comfort	199378-7
	Protector assembly set	UR101C, UR201C, PDC01, PDC1200, PDC1500	String trimmer harness for PDC01, PDC1200, PDC1500	191E43-4
	Band assembly set	UR101C, UR201C, PDC01, PDC1200, PDC1500	String trimmer harness for PDC01, PDC1200, PDC1500	197243-4

Attachments for loop handle brushcutter

Split shaft attachments

Model	item	Recommend power unit models
EM401MP	Brushcutter Cutting width: 300mm (String trimmer head): 230mm (Brush cutter blade size) Spindle size: M10 x 1.25LH Arbor size: 25.4mm Gear ratio: 0.74 (14: 19)	DUX60, UX01G
EM402MP	Brushcutter Blade size: 230mm Spindle size: M10 x 1.25LH Arbor size: 25.4mm Gear ratio: 0.74 (14: 19)	DUX60
EM403MP	Brushcutter Cutting width: 450mm (String trimmer head): 230mm (Brush cutter blade size) Spindle size: M10 x 1.25LH Arbor size: 25.4mm Gear ratio EM403MP: 0.74 (14: 19) High speed type EM404MP: 0.62 (13: 21) High torque & Low noise type	DUX60, UX01G
EM404MP		DUX60 with CE mark, UX01G with CE mark
EM405MP	Brushcutter (Narrow guard for String trimmer head) Cutting width: 450mm Spindle size: M10 x 1.25LH Gear ratio EM405MP: 0.74 (14: 19) High speed type EM406MP: 0.62 (13: 21) High torque & Low noise type	DUX60, UX01G
EM406MP		DUX60 with CE mark, UX01G with CE mark,
EM407MP	Rotary scissors attach Set Cutting width: 230mm Stone & grass antiscattering brushcutter attachment.	DUX18, DUX60, UX01G
	Replacement blade P/N: SY00146013 Replacement blade P/N: SY00146014	
EM408MP	Brushcutter Cutting width: 300mm (String trimmer head): 230mm (Brush cutter blade size) Spindle size: M10 x 1.25LH Arbor size: 25.4mm Gear ratio: 0.74 (14: 19)	DUX18, DUX60, UX01G
EM409MP	Brushcutter (Narrowguard for String trimmer head) Cutting width: 300mm Spindle size: M10 x 1.25LH Gear ratio: 0.74 (14: 19)	DUX18, DUX60, UX01G
EE400MP	Edger attachment Blade size: Diameter: 203mm Hole diameter: 25.4mm Replacement blade P/N: 196745-7	DUX18, DUX60, UX01G
UB400MP	Blower Max. Air volume: 16.6 m ³ /min (UX01G) Except for European, Austrarian, markets .Newzealand, Chinese & Korean	DUX18, DUX60, UX01G
UB401MP	Blower Max. Air volume: 16.4 m ³ /min (UX01G)	DUX18, DUX60, UX01G
UB402MP	Blower Max. Air volume: 6.2 m ³ /min (UX01G)	DUX18, DUX60, UX01G
PF400MP	Pump Attachment Hose size (Inner diameter): 25mm / 1" DUX18/ DUX60/ UX01G Max. lift height (m): 11/ 14/ 15 Max. flow rate (l/min): 120/ 145/ 150	DUX18, DUX60, UX01G

Model	item	Recommend power unit models
EY402MP	Pole saw Guide bar length: 25cm (10") Saw chain: 90PX-40links	DUX18, DUX60, UX01G
EY403MP	Pole saw Guide bar length: 30cm (12") Saw chain: 90PX-46links or 91PX-46links Motor Mount: A041	DUX18, DUX60, UX01G
EN401MP	Pole hedge trimmer, Angle adjustment, Effective cutting length: 490mm Shear blade 500set P/N: 198049-3 with End cover set: P/N: 197763-8 (MG), 197768-8 (ME)	DUX18, DUX60, UX01G
EN402MP	Pole hedge trimmer Effective cutting length: 500mm Shear blade 500set P/N: 1912G3-7	DUX18, DUX60, UX01G
EN410MP	Pole hedge trimmer Straight Effective cutting length: 490mm Shear blade 500set P/N: 198049-3 with End cover set: P/N: 197763-8 (MG), 197768-8 (ME)	DUX18, DUX60, UX01G
EN420MP	Ground trimmer Effective cutting length: 250mm Shear blade 250set P/N: 198195-2	DUX18, DUX60, UX01G
EN422MP	Ground trimmer Effective cutting length: 250mm Shear blade 250 set P/N: 122D74-6	DUX18, DUX60, UX01G
EN424MP	Ground trimmer Effective cutting length: 330mm Shear blade 330 set P/N: 1912V6-6	DUX18, DUX60, UX01G
KR400MP	Cultivator Cultivating width: 160mm	DUX18, DUX60, UX01G
KR401MP	Cultivator Cultivating width: 220mm Rotor LR set: P/N: 199204-0	DUX18, DUX60, UX01G
WA400MP	Weeding Effective cutting length: 220mm Weeding blade 220 set P/N: 1913L5-4 Cultivator blade 170 set P/N: 1913L7-0 Weeding blade 80 set P/N: 1913L6-2	DUX18, DUX60, UX01G
BR400MP	Power brush Working width: 600mm Brush wheel (1pc) P/N: XNR0000548	DUX18, DUX60, UX01G
SW400MP	Power sweep Working width: 590mm Sweeper wheel (1pc) P/N: XNR0000549	DUX18, DUX60, UX01G
EJ400MP	Coffee harvester	DUX18, DUX60, UX01G
SN400MP	Snow Blower Attachment Max snow throwing distance: 12m Snow clearing width: 300mm	DUX18, DUX60, UX01G
LE400MP	Shaft extension attachment (1.08m (42-1/2")) For Pole saw, Pole hedge trimmer and Coffee harvester	DUX18, DUX60, UX01G

Saw Chain and Guide Bar

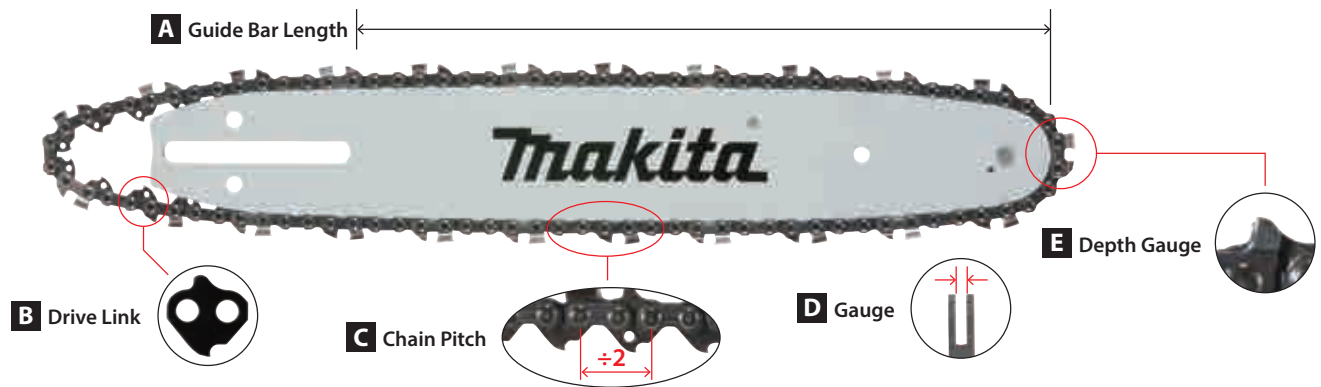

A Guide Bar Length
Guide bar's length is represented by cutting length, which is different from its whole length.



B Drive Link
The length of saw chain is determined by counting the number of drive links in the saw chain.

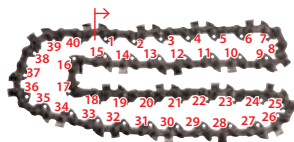

C Chain Pitch
Chain pitch is the size of the chain and it is defined by the distance between any three consecutive rivets divided by two. Pitch is important because the drive sprocket must be the same pitch as the chain.



D Gauge
Chain Gauge is thickness of drive link which will fit into the guide bar groove. Chain gauge must be the same as guide bar gauge.

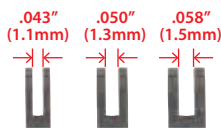

E Depth Gauge
Depth gauge determines how deep the cutting teeth gets into the wood. Cutting depth can be checked by the gap between top of cutter and depth gauge.



General Saw Chain Character

D Gauge	.043" (1.1mm)	.050" (1.3mm)	.058" (1.5mm)	.063" (1.6mm)
C Chain Pitch				
1/4"		25AP		
.325"LP	80TXL			
3/8"LP	M41 90PX	M43 91PX 91VXL		
.325" narrow kerf		95VPX 95TXL		
.325"		20BPX	21BPX 21LPX	22BPX 22LPX
3/8"		72V	73DPX 73LGX 73LPX	
.404"				27X

Guide Bar Type

Sprocket Nose Bars
Sprocket nose bars have a rotating sprocket mounted at the tip of the bar. As the chain moves along the bar, the sprocket teeth carry the chain around the tip smoothly with less friction.



High durability sprocket nose bar
Longer nose life thanks to larger nose sprocket than normal sprocket bars. Multiple rivets can be found on bar surface.



Solid Carving Bars
Carving bars are made of high-quality steel and high wear resistant stellite have been welded onto the tip. Bar tip is designed to have small radius for precision cutting. The carving bars are made for especially pruning and carving.



Guide Bar Maintenance

Chain Tension
Check the chain tension before use. The saw chain may become loose after many hours of use.



File Bar Edge
File bar edge with a flat file to keep it 90° once a week.



Clean Guide Bar
Clean out chips and sawdust every time when you sharpen or replace saw chain.



Bar Nose Grease
Lubricate a whole sprocket regularly so that the saw chain can rotate with less friction.



Outdoor Power Equipment

Chain Saws

Guide Bar / Saw Chain / Guide Bar Cover / Drive sprocket

Cutter type: CC: Chamfer chisel, SC: Semi chisel, MC : Micro chisel, FC: Full chisel

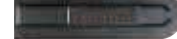
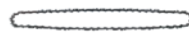

Model No.	Guide Bar					Saw Chain					Bar Cover	Drive sprocket	
	Bar length	Motor Mount	Type	Part No.	No. of drive links	Gauge	Pitch	Type OREGON	Cutter type	Part No. (Carton)	Part No.	Type	Part No.
Pole Saws													
DUA200	20cm/8"	A041	Sprocket nose bar	191453-3	38	1.1mm/.043"	.325"LP	80TXL	MC	191451-7	413G28-5	.325"LP 7T	
EY402MP	25cm/10"	A041	Sprocket nose bar	191G14-3	40	1.1mm/.043"	3/8"LP	90PX	CC	191H00-0	452093-7 / 458501-6	3/8"LP 6T	226992-7
EY403MP	30cm/12"	A041		191G15-1	46					191H01-8	419288-5 / 413G23-5		
DUA250, DUA251	25cm/10"	A041	Sprocket nose bar	191G22-4	40	1.3mm/.050"	3/8"LP	91PX	CC	191H08-4	452093-7 / 458501-6	3/8"LP 6T	226992-7
DUA300, DUA301	30cm/12"	A041	191G23-2	46	191H10-7					419288-5 / 413G23-5			
UA001G, UA002G													
UA003G, UA004G													
Cordless Chain Saws													
DUC101, UC100D	10cm/4"	F002	without sprocket	1910W0-3	26	1.1mm/.043"	.325"LP	80TXL	MC	1910V6-4	413M40-1	.325"LP 7T	1911W5-9
DUC150, UC029G	15cm/6"	F002	without sprocket	1912F1-4	32	1.1mm/.043"	.325"LP	80TXL	MC	1912E8-3	413T67-3	.325"LP 7T	1911W5-9
DUC122	11.5cm/4-1/2"	-	without sprocket	158476-6	42	1.3mm/.050"	1/4"	25AP	MC	191G95-7	416311-7	1/4" 9T	221527-9
	25cm/10"	-	Solid carving bar	1911A1-3	60	1.3mm/.050"	1/4"	25AP	MC	191G96-5	452093-7 / 458501-6	1/4" 9T	198259-2
	25cm/10"	A041	Sprocket nose bar	191T85-8	46	1.1mm/.043"	.325"LP	80TXL	MC	191T89-0	452093-7 / 458501-6	Sprocket .325" LP 7 tooth	1911W5-9
	30cm/12"	A041		191T86-6	51					191T90-5	419288-5 / 413G23-5		
DUC204	20cm/8"	A041	Sprocket nose bar	191G13-5	33	1.1mm/.043"	3/8"LP	90PX	CC	191G99-9	458503-2	Sprocket 3/8" LP 6 tooth	199063-2
DUC254	25cm/10"	A041		191G14-3	40					191H00-0	452093-7 / 458501-6		
DUC304	30cm/12"	A041		191G15-1	46					191H01-8	419288-5 / 413G23-5		
DUC254C	25cm/10"	A041	Sprocket nose bar	191G22-4	40	1.3mm/.050"	3/8"LP	91PX	CC	191H08-4	452093-7 / 458501-6	Sprocket 3/8" LP 6 tooth	199063-2
	30cm/12"	A041	191G23-2	46	191H10-7					419288-5 / 413G23-5			
UC021G, UC022G	30cm/12"	A041	Sprocket nose bar	191T86-6	51	1.1mm/.043"	.325"LP	80TXL	MC	191T90-5	419288-5 / 413G23-5	Sprocket .325" LP 7 tooth	191V91-5
UC023G, UC024G	35cm/14"	A041		191T87-4	59					191T91-3	419288-5 / 413G23-5		
UC025G, UC026G	40cm/16"	A041		191T88-2	64					191T92-1	419242-9 / 413G21-9		
	25cm/10"	-	Solid carving bar	1911A1-3	60	1.3mm/.050"	1/4"	25AP	MC	191G96-5	452093-7 / 458501-6	Sprocket 1/4" 9 tooth	198259-2
	25cm/10"	A041	Sprocket nose bar	191T85-8	46	1.1mm/.043"	.325"LP	80TXL	MC	191T89-0	452093-7 / 458501-6	Sprocket .325" LP 7 tooth	1911W5-9
	30cm/12"	A041		191T86-6	51					191T90-5	419288-5 / 413G23-5		
	35cm/14"	A041		191T87-4	59					191T91-3	419288-5 / 413G23-5		
	40cm/16"	A041		191T88-2	64					191T92-1	419242-9 / 413G21-9		
DUC256	25cm/10"	A041	Sprocket nose bar	191G14-3	40	1.1mm/.043"	3/8"LP	90PX	CC	191H00-0	452093-7 / 458501-6	Sprocket 3/8" LP 6 tooth	199063-2
DUC306	30cm/12"	A041		191G15-1	46					191H01-8	419288-5 / 413G23-5		
DUC356	35cm/14"	A041		191G16-9	52					191H02-6	419288-5 / 413G23-5		
DUC406	40cm/16"	A041		191G17-7	56					191H03-4	419242-9 / 413G21-9		
DUC256C	25cm/10"	A041	Sprocket nose bar	191G22-4	40	1.3mm/.050"	3/8"LP	91PX	CC	191H08-4	452093-7 / 458501-6	Sprocket 3/8" LP 6 tooth	199063-2
	30cm/12"	A041		191G23-2	46					191H10-7	419288-5 / 413G23-5		
	35cm/14"	A041		191G24-0	52					191H11-5	419288-5 / 413G23-5		
	40cm/16"	A041		191G25-8	56					191H12-3	419242-9 / 413G21-9		
	30cm/12"	A041	Sprocket nose bar	191G15-1	46	1.1mm/.043"	3/8"LP	90PX	CC	191H01-8	419288-5 / 413G23-5	Sprocket 3/8" LP 6 tooth	199063-2
	35cm/14"	A041		191G16-9	52					191H02-6	419288-5 / 413G23-5		
	40cm/16"	A041		191G17-7	56					191H03-4	419242-9 / 413G21-9		
DUC307	30cm/12"	A041	Sprocket nose bar	191G23-2	46	1.3mm/.050"	3/8"LP	91PX	CC	191H10-7	419288-5 / 413G23-5	Sprocket 3/8" LP 6 tooth	199063-2
DUC357	35cm/14"	A041		191G24-0	52					191H11-5	419288-5 / 413G23-5		
DUC407	40cm/16"	A041		191G25-8	56					191H12-3	419242-9 / 413G21-9		
	25cm/10"	-	Solid carving bar	1911A1-3	60	1.3mm/.050"	1/4"	25AP	MC	191G96-5	452093-7 / 458501-6	Sprocket 1/4" 9 tooth	198259-2
DUC303	30cm/12"	A041	Sprocket nose bar	191G15-1	46	1.1mm/.043"	3/8"LP	90PX	CC	191H01-8	419288-5 / 413G23-5	Sprocket 3/8" LP 6 tooth	199063-2
DUC353	35cm/14"	A041		191G16-9	52					191H02-6	419288-5 / 413G23-5		
DUC400	40cm/16"	A041		191G17-7	56					191H03-4	419242-9 / 413G21-9		
DUC305	30cm/12"	A041	Sprocket nose bar	191G23-2	46	1.3mm/.050"	3/8"LP	91PX	CC	191H10-7	419288-5 / 413G23-5	Sprocket 3/8" LP 6 tooth	199063-2
DUC355	35cm/14"	A041		191G24-0	52					191H11-5	419288-5 / 413G23-5		
DUC405	40cm/16"	A041		191G25-8	56					191H12-3	419242-9 / 413G21-9		

Model No.	Guide Bar					Saw Chain					Bar Cover	Drive sprocket	
	Bar length	Motor Mount	Type	Part No.	No. of drive links	Gauge	Pitch	Type OREGON	Cutter type	Part No. (Carton)	Part No.	Type	Part No.
UC002G UC003G UC004G UC005G UC006G UC007G	25cm/10"	-	Solid carving bar	1911A1-3	60	1.3mm/.050"	1/4"	25AP	MC	191G96-5	452093-7 / 458501-6	Sprocket 1/4" 9T	191V92-3
	25cm/10"	A041	Sprocket nose bar	191T85-8	46	1.1mm/.043"	.325" LP	80TXL	MC	191T89-0	452093-7 / 458501-6	Sprocket .325" LP 7 tooth	191V91-5
	30cm/12"	A041		191T86-6	51					191T90-5	419288-5 / 413G23-5		
	35cm/14"	A041		191T87-4	59					191T91-3	419288-5 / 413G23-5		
	25cm/10"	A041	Sprocket nose bar	191G14-3	40	1.1mm/.043"	3/8"LP	90PX	CC	191H00-0	452093-7 / 458501-6	Sprocket 3/8"LP 6 tooth	191V90-7
	30cm/12"	A041		191G15-1	46					191H01-8	419288-5 / 413G23-5		
	35cm/14"	A041		191G16-9	52					191H02-6	419288-5 / 413G23-5		
	25cm/10"	A041	Sprocket nose bar	191G22-4	40	1.3mm/.050"	3/8"LP	91PX	CC	191H08-4	452093-7 / 458501-6	Sprocket 3/8"LP 6 tooth	191V90-7
	30cm/12"	A041		191G23-2	46					191H10-7	419288-5 / 413G23-5		
	35cm/14"	A041		191G24-0	52					191H11-5	419288-5 / 413G23-5		
UC010G UC011G UC012G UC013G UC014G UC015G UC016G UC017G UC020G	30cm/12"	A041	Sprocket nose bar	191T86-6	51	1.1mm/.043"	.325"LP	80TXL	MC	191T90-5	419288-5 / 413G23-5	Sprocket .325" LP 7 tooth	191V91-5
	35cm/14"	A041		191T87-4	59					191T91-3	419288-5 / 413G23-5		
	40cm/16"	A041		191T88-2	64					191T92-1	419242-9 / 413G21-9		
	45cm/18"	A041	191X03-0	70	191X04-8	419242-9 / 413G21-9	Sprocket 3/8"LP 6 tooth	191V90-7					
	30cm/12"	A041	Sprocket nose bar	191G15-1	46	1.1mm/.043"			3/8"LP	90PX	CC	191H01-8	419288-5 / 413G23-5
	35cm/14"	A041		191G16-9	52							191H02-6	419288-5 / 413G23-5
	40cm/16"	A041		191G17-7	56		191H03-4	419242-9 / 413G21-9					
	30cm/12"	A041	Sprocket nose bar	191G23-2	46	1.3mm/.050"	3/8"LP	91PX	CC	191H10-7	419288-5 / 413G23-5	Sprocket 3/8"LP 6 tooth	191V90-7
	35cm/14"	A041		191G24-0	52					191H11-5	419288-5 / 413G23-5		
	40cm/16"	A041		191G25-8	56					191H12-3	419242-9 / 413G21-9		
45cm/18"	A041	191G26-6	62	191H13-1	419242-9 / 413G21-9								

Electric Chain Saws

UC3041A UC3541A UC4041A	30cm/12"	A041	Sprocket nose bar	191G15-1	46	1.1mm/.043"	3/8"LP	90PX	CC	191H01-8	419288-5 / 413G23-5	Sprocket 3/8"LP 6 tooth	221526-1
	35cm/14"	A041		191G16-9	52					191H02-6	419288-5 / 413G23-5		
	40cm/16"	A041		191G17-7	56					191H03-4	419242-9 / 413G21-9		
	30cm/12"	A041	Sprocket nose bar	191G23-2	46	1.3mm/.050"	3/8"LP	91PX	CC	191H10-7	419288-5 / 413G23-5	Sprocket 3/8"LP 6 tooth	221521-1
	35cm/14"	A041		191G24-0	52					191H11-5	419288-5 / 413G23-5		
	40cm/16"	A041		191G25-8	56					191H12-3	419242-9 / 413G21-9		
UC3050A,UC3550A UC4050A,UC4550A UC3051A,UC3551A UC4051A,UC4551A	30cm/12"	A041	Sprocket nose bar	191G23-2	46	1.3mm/.050"	3/8"LP	91PX	CC	191H10-7	419288-5 / 413G23-5	Sprocket 3/8"LP 6 tooth	221521-1
	35cm/14"	A041		191G24-0	52					191H11-5	419288-5 / 413G23-5		
	40cm/16"	A041		191G33-9	52					191H12-3	419242-9 / 413G21-9		
	40cm/16"	A041		191G25-8	56					191H13-1	419242-9 / 413G21-9		
	45cm/18"	A041		191G34-7	62					191H13-1	419242-9 / 413G21-9		

NEW Saw chain M41 (Similar to 90PX), M43 (Similar to 91PX)



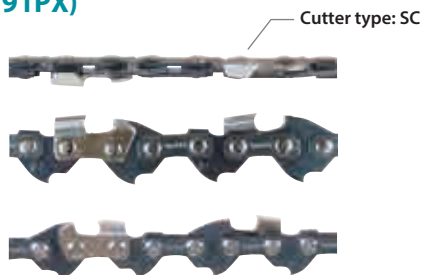

Low profile chain blades.

Compared to regular 3/8" saw chains, due to its low cutting resistance, it is suitable for use with small-displacement gas-powered chain saws and cordless chain saws.

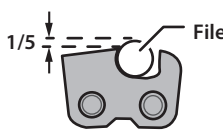
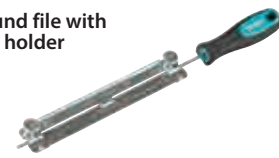
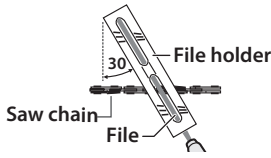
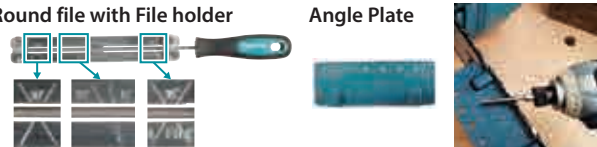

Guide Bar	NEW Saw Chain					Similar Saw Chain				
Bar length	Gauge	Pitch	Type Makita	No. of drive links	Part No. (Carton)	Gauge	Pitch	Type OREGON	No. of drive links	Part No. (Carton)
25cm/10"	1.1mm/.043"	3/8" (Similar to LP)	M41	40	1914F1-6	1.1mm/.043"	3/8"LP	90PX	40	191H00-0
30cm/12"				46	1914F2-4				46	191H01-8
35cm/14"				52	1914F3-2				52	191H02-6
40cm/16"				56	1914F4-0				56	191H03-4
25cm/10"	1.3mm/.050"	3/8" (Similar to LP)	M43	40	1914F5-8	1.3mm/.050"	3/8"LP	91PX	40	191H08-4
30cm/12"				46	1914F6-6				46	191H10-7
35cm/14"				52	1914F7-4				52	191H11-5
40cm/16"				56	1914F8-2				56	191H12-3

Sharpening Saw Chain

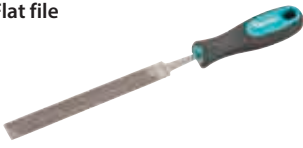
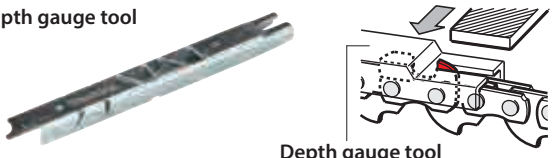
<How to Sharpening Saw Chain>	<Using accessory>
<p>1. To sharpen Cutting Corner & Side Plate</p>	
<p>To sharpen Cutting corner & Side plate, use Round file.</p>  <p>Cutting corner Side plate</p>	<p>Round file Round file bit (for power tool)</p> 
<p>When use a file, try to keep 1/5 of the Round file diameter appeared from the saw chain. With a File holder, it is easy to keep 1/5 file diameter appeared.</p> 	<p>Round file with File holder</p> 
<p>There are appropriate angles to use a file, according to a Saw Chain type. File holder or Angle plate are used to see the appropriate angle.</p> 	<p>Round file with File holder Angle Plate</p> 
<p>If you have to sharpen Saw Chain outdoors where it is difficult to secure your Chain Saw, drive the Filing vise into the wood and you can use a file anywhere.</p>	<p>Filing vise</p> 
<p>2. To grind Depth gauge</p>	
<p>Use a Flat file to adjust Depth Gauge height.</p> 	<p>Flat file</p> 
<p>Depth gauge tool is to see adjustment necessity and how much to grind off Depth Gauge. Put on Depth gauge tool on Depth Gauge and grind off Depth Gauge's exposed part with a Flat file.</p>	<p>Depth gauge tool</p> 

Diameter and sharpening angle of Round file

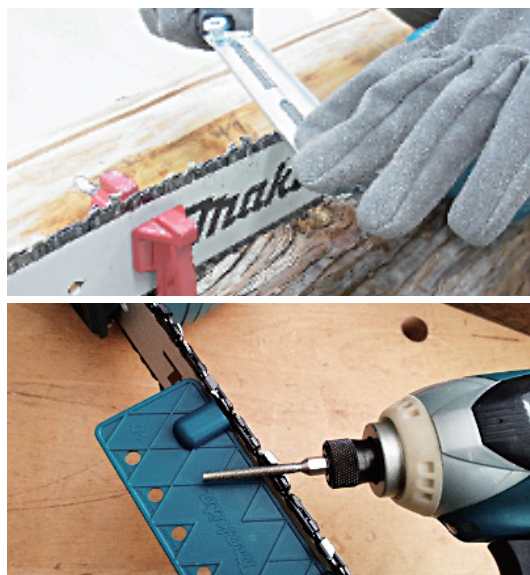

Model	File Diameter	Sharpening Angle	Depth Gauge
25AP	4.0mm / 5/32"	30°	0.65mm / .025"
80TXL	4.0mm / 5/32"	30°	0.65mm / .025"
90PX	4.5mm / 11/64"	30°	0.65mm / .025"
91PX / M43 / M41	4.0mm / 5/32"	30°	0.65mm / .025"
91VXL			
95VPX / 95TXL	4.8mm / 3/16"	30°	0.65mm / .025"
20BPX	4.8mm / 3/16"	30°	0.65mm / .025"
21BPX / 22BPX			
21LPX	4.8mm / 3/16"	25°	0.65mm / .025"
72V	5.5mm / 7/32"	25°	0.65mm / .025"
73DPX	5.5mm / 7/32"	30°	0.65mm / .025"
73LPX	5.5mm / 7/32"	25°	0.65mm / .025"
27X	5.5mm / 7/32"	30°	0.75mm / .030"

File and File holder

For Model: Chain saw

*with grip

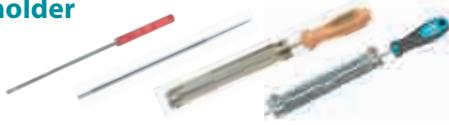

Saw chain type	File			File and File holder
	Size	Q'ty	Part No.	Part No.
25F, 25AP, 80TXL, 91P, 91PX, 91PXL, 91VXL M41, M43	4mm 5/32"	1	*744003-1	-
		2	D-67359	D-70948
		12	D-67365	
90PX, 90SG	4.5mm 11/64"	2	D-67371	D-70954
		12	D-67387	
95VPX/ TXL, 20BPX/ LPX/, 21BPX/ LPX, 22BPX/ LPX, 082, 086, 686, 484	4.8mm 3/16"	2	D-67393	197712-5
		12	D-67402	D-70960
72DPX/ LPX, 73DPX/ LPX, 75DPX/ LPX	5.2mm 13/64"	2	D-67418	D-70976
		12	D-67424	
72DPX/ LPX/ APX/ EXL/ EXJ/ LGX/ JGX/ JPX/ RDV, 73DPX/ LPX/ EXL/ EXJ/ LGX/ JGX/ JPX/ RDV, 75DPX/ LPX / EXL/ EXJ/ LGX/ JGX/ JPX/ RDV, 496, 093, 099	5.5mm 7/32"	2	D-67430	D-70982
		12	D-67446	

Round file bit

For all saw chain



Description	Size	Part No.
Round File bit 6.35mm (1/4) Hex shank (MZ)	Ø4.0mm (5/32")	D-73748
	Ø4.5mm (11/64")	D-73754
	Ø4.8mm (3/16")	D-73760
	Ø5.2mm (13/64")	D-73776
	Ø5.5mm (7/32")	D-73782

Angle plate / Angle plate & Diamond file bit set

For all saw chain



Description	Diamond File Size	Part No.
Angle Plate (25 / 30deg.)	-	D-75605
Angle Plate & Diamond File bit 1/4" Hex shank (MZ) set	Ø4.0mm (5/32")	D-75611
	Ø4.5mm (11/64")	D-75627
	Ø4.8mm (3/16")	D-75633
	Ø5.2mm (13/64")	D-75649
	Ø5.5mm (7/32")	D-75655

Flat file, Depth gauge

For all saw chain

Depth gauge : .025 / 0.64mm



Flat file		Depth gauge	Flat file and File handle and Depth gauge
Q'ty	Part No.	Part No.	Part No.
1	D-67452	D-67474	D-70998
12	D-67468		

File set for in roll up pouch

For all saw chain



Description	Part No.
Ø4.0mm Round File(3pcs) / File Holder / Flat File / Handle(2pcs) / Depth Gauge	D-72154
Ø4.5mm Round File(3pcs) / File Holder / Flat File / Handle(2pcs) / Depth Gauge	D-72160
Ø4.8mm Round File(3pcs) / File Holder / Flat File / Handle(2pcs) / Depth Gauge	D-72176
Ø5.2mm Round File(3pcs) / File Holder / Flat File / Handle(2pcs) / Depth Gauge	D-72182
Ø5.5mm Round File(3pcs) / File Holder / Flat File / Handle(2pcs) / Depth Gauge	D-72198

File handle



Q'ty	Part No.
1	D-67496
50	D-67505

Filing vise



Part No.
D-67480

Chain oil



Size	Part No.
100ml	182229-1
100ml	199897-3
1L	195093-1
1L	196946-7

Spike bumper



Related models	Part No.
DUC122	197944-4
DUC254	199067-4

Outdoor Power Equipment

Holster for DUC101, UC100D & DUC150



Related models	Part No.
DUC101, UC100D	1911R0-4
DUC150	1913K4-9

Angled attachment set for Pole saw



Related models	Part No.
DUA250, DUA251, DUA300, DUA301, UA001G, UA002G, UA003G, UA004G	1910J6-0

Hook holder for extension cord

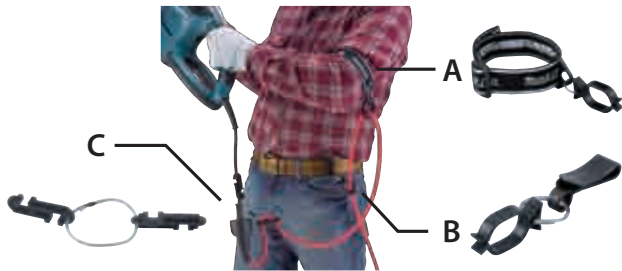

Related models	Type	Description	Part No.
BO001CG, BO002CG, BO003CG, BO004CG, BO005CG, BO006CG, UH4261, UH4570, UH4861, UH5261, UH5570, UH5580, UH6570, UH6580, UH7580	A	Arm band complete set	194679-8
DUP361, DUP362, UH4261, UH4570, UH4861, UH5261, UH5570, UH5580, UH6570, UH6580, UH7580	B	Cord holder complete set	194677-2
UH4261, UH4570, UH4861, UH5261, UH5570, UH5580, UH6570, UH6580, UH7580	C	Hook complete	158024-1

Shear blade & Blade cover for Grass Shear



Related models	Cutting width	1	2	3
		Blade assembly	Blade cover	Grass Receiver
DUM604, UM600D, UM164D, UM167D	160mm	195267-4	452055-5	457426-1
DUM111 UM110D	110mm	191N23-4	459011-6	454880-0

Conversion from Hedge Trimmer to Grass Shear

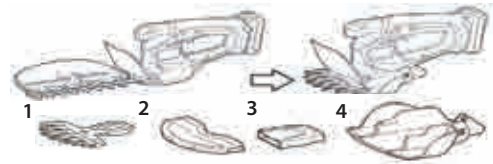

Related models	Cutting width	1	2, 3 & 4	3
		Blade assembly	Blade cover, Grass receiver & Clank cover set	Clank cover
UH201D	160mm	195267-4	198412-0	452198-3
	110mm	191N23-4	191N25-0	452198-3

Conversion from Grass Shear to Hedge Trimmer

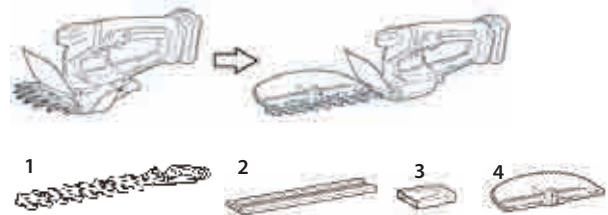

Related models	Blade assembly	1	2	2 & 3	4
		Surface treat	Blade cover	Blade cover set	Chip receiver
UM110D, DUM111	191N24-2	BLACK OXIDE	458342-0	195274-7	198401-5
UM110D, DUM111 DUM604, UM600D	198408-1	NICKEL PLATING	458342-0	195274-7	198401-5

Long attachment handle (Extension handle kit)

*with grass shear blade



Related models	Part No.
DUM604, *DUH202, UM110D, DUM111, UM600D, UM603D, *UH201D	198516-8

Shear blade, Blade guard, End guard, Blade cover & Chip receiver for Hedge Trimmer

- *Attached to blade assembly or blade set
- ** With screw & wrench
- ***With screw, wrench & blade cover
- ****For Blade without end cover
- *****For Blade with end cover



Cordless Hedge Trimmer

Model No.	Blade size	Blade assembly		Blade guard	End guard (End cover / Tip guard / Branch catcher)	Blade cover	Chip receiver		Grease
		Part No.	Description				Part No.	Description	
UH201D	200mm	198408-1	Stain-free blade	-	-	451816-0 458342-0	198401-5		*No.1
DUH506	500mm	1914G4-7	-	Built in the Blade	-	413L91-8	1910T1-0	One-touch installation / removal	*No.2
DUH606	600mm	1914G5-5	-		-	413L92-6	1910T2-8		*No.2
DUH507	500mm	1911J1-6	-		-	413L91-8	1910T1-0		*No.2
DUH607	600mm	1911J2-4	-		-	413L92-6	1910T2-8		*No.2
DUH501	500mm	191T44-2	Curving blade		With Blade guard *412908-0	Without End guard *345205-8	412910-3		191W56-3
DUH601	600mm	191R53-9	-	412911-1			191R51-3		*No.2
DUH751	750mm	191R54-7	Curving blade	With Blade guard *412908-0	Without End guard *345205-8	412912-9	191R52-1		*No.2
DUH502	500mm	191T47-6	High grade blade			459120-1	191W56-3		*No.2
DUH602	600mm	191R57-1	High grade blade			459121-9	191R51-3		*No.2
DUH752	750mm	191R58-9	High grade blade			459122-7	191R52-1		*No.2
DUH604S	600mm	191Y03-6	Single side blade Curving blade	With Blade guard *347962-4	-	412769-8	191D33-1	Without bind head screw M5X12 (P/N:915211-3 4pics)	*No.2
DUH754S	750mm	191Y05-2	Single side blade Curving blade	With Blade guard *347962-4	-	412770-3	191D34-9	Without bind head screw M5X12 (P/N:915211-3 5pics)	*No.2
UH004G	600mm	191R53-9	-	With Blade guard *412908-0	Without End guard *345205-8	412911-1	191R51-3	One-touch installation / removal	*No.2
UH005G	750mm	191R54-7	Curving blade			412912-9	191R52-1		*No.2
UH006G	600mm	191R55-5	Rough-cutting blade	With Blade guard *413794-2	*	412911-1	191R51-3		*No.2
UH007G	750mm	191R56-3	Rough-cutting blade			412912-9	191R52-1		*No.2
UH008G	600mm	191R57-1	High grade blade	With Blade guard *412908-0	Without End guard *345205-8	459121-9	191R51-3		*No.2
UH009G	750mm	191R58-9	High grade blade			459122-7	191R52-1		*No.2
UH013G	600mm	191Y03-6	Single side blade Curving blade	With Blade guard *347962-4	-	413B98-4	191D33-1	Without bind head screw M5X12 (P/N:915211-3 4pics)	*No.2
UH014G	750mm	191Y05-2	Single side blade Curving blade			413B99-2	191D34-9	Without bind head screw M5X12 (P/N:915211-3 5pics)	*No.2
UH020G	500mm	1914G4-7	-	Built in the Blade	-	413L91-8	1910T1-0	One-touch installation / removal	*No.2
UH021G	600mm	1914G5-5	-			413L92-6	1910T2-8		*No.2

Electric Hedge Trimmer





Model No.	Blade size	Blade assembly		Blade guard	End guard (End cover / Tip guard / Branch catcher)	Blade cover	Chip receiver		Grease	
		Part No.	Description				Part No.	Description		
UH4261	420mm	140826-9	-	Built in the blade	With end guard *345205-8	452683-6	195050-9	One-touch installation / removal	No.2	
UH4861	480mm	140830-8	-			-	452684-4		195050-9	No.2
UH5261	520mm	140827-7	-			-	452685-2		195050-9	No.2
UH4570	450mm	194660-9	Stain-free blade				450489-6		194681-1	*No.2
UH5570	550mm	194663-3					450489-6			*No.2
UH6570	650mm	194666-7					450490-1			*No.2
UH5580	550mm	194671-4 EU:196687-5					450489-6		194681-1	*No.2
UH6580	650mm	194673-0 EU:196688-3					450490-1			*No.2
UH7580	750mm	194675-6					450490-1		*No.2	

Cordless Pole Hedge Trimmer

*Attached to Blade assembly

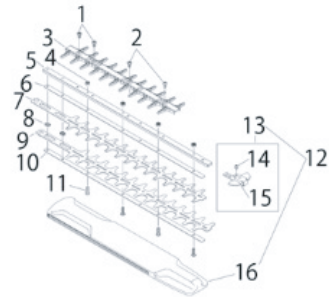
Model No.	Blade size	Blade assembly		Blade guard	End guard (End cover / Tip guard / Brunch catcher)	Blade cover	Chip receiver		Grease
		Part No.	Description				Part No.	Description	
DUN461W UN460WD	460mm	191P00-8	-	Without Blade guard	-	413720-1	191T43-4	One-touch installation / removal	*No.1
DUN500W	500mm	191C14-9	Curving blade		*345205-8	458413-3	1910M5-3		*No.2
DUN501W	500mm	191E73-5	-			459120-1			*No.2
DUN600L	600mm	191C13-1	Curving blade			458414-1	1910M6-1		*No.2
UN001G	600mm	1914E7-7	-		-	347A61-8	458414-1		1910T2-8

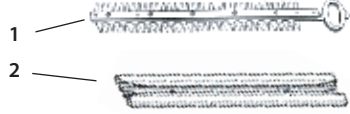
Hedge Trimme attachment , Petrol Hedge Trimme & Petrol Pole Hedge Trimme

Model No.	Blade size	Item	Part No.	Part neme	Item	
EN401MP EN410MP	500mm 490mm	12	196264-3	Blade cover & End cover set		
		13	196969-5	End cover set		
		1-11 set	198049-3	Shear blade assembly set M		
		1-11, 13 set	197763-8	Shear blade assembly set MG		
			197768-8	Shear blade assembly set ME		
EN401MP	490mm	Grease	---	No.1		
			197439-7	Grease vessel set		No.0 80g
		7, 8	725187-4	Shear blade		
EN420MP	250mm	7 8	725197-1	Shear blade		
		12	458345-4	Blade cover		
		1-11	198195-2	Shear blade assembly set		
		Grease	---	No.1		
EN402MP	500mm	1	1912G3-7	Shear blade 500 set		
		2	413R17-6	Blade cover 500		
		Grease	---	*No.2		
EN422MP	250mm	1	1912G2-9	Shear blade 250 set		
		2	413P96-2	Blade cover 250		
		Grease	---	*No.2		

Grease vessel set

Description	Size	Part No.
For Pole hedge trimmer and Multi-tool attachments (Cultivator, Power brush and Power sweep)	80ml	-
(GREASE NO.0)		For RUSSIA
For string trimmer, Brushcutter and Hedge trimmer (GREASE NO.2)		-
		For RUSSIA

Pruning Shear blade



Shear blade (U)



Shear blade (L)

Do not re-use Stop Ring E-4 when reassembling. Stop Ring E-4

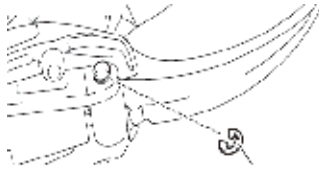

Exp. Fig. E-4

*With Stop Ring E-4 (P/N:961011-9)

**Hex socket button head screw M3x6 P/N:266183-8 & Shoulder bolt M8 P/N:251573-8 are also necessary.

Related models	Type	Shear blade (U)	Shear blade (L)
		Part No.	Part No.
DUP361 DUP362	Standard	*197588-0	197749-2
		*197366-8	EU : 197367-6
	For hard branch	199168-8	199169-6
UP100D DUP180	Standard	*199314-3 *199372-9	**199171-9
		1911W2-5	1911W1-7
DUP180		1913P4-4	1913P3-6

Branch catcher set for thin branch

with Shear blades for thin branch



Branch catcher set



Related models	Part No.
DUP361, DUP362	199311-9

Diamond file for shear blade & Dresser stone set

Diamond file



Dresser stone



Name	Related models	Part No.
Diamond file	DUP361, DUP362	794530-8
Dresser stone set	DUP180, UP100D	1912E4-1

Battery powered pruning shear others accessory

DUP361
DUP362

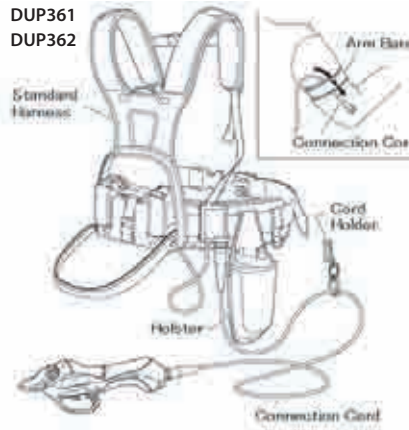

Holster
UP100D,
DUP180



Battery adapter
DUP180



Related models	Item	Part No.
DUP361 DUP362	Standard Harness	161377-9
	Narrow Strap Harness for Summer	161603-6
	Holster	161379-5
	Arm Band	166062-9
	Cord Holder	154511-8
UP100D, DUP180	Connection Cord	661445-3
UP100D, DUP180	Holster	162C23-5
DUP180	Battery adapter (cord length 1.4m)	630E23-0







Backpack Mist Blower

Related models	Items	Part No.
PM001G	Deflector set You can discharge the mist upward or downward	198248-7 198249-5 (EU)
	Sternum strap 	196733-4





Outdoor Power Equipment

Wheelbarrow attachment











*Can be used by attaching to Dump unit installed on Base unit (Wheelbarrow body).

Still photo	Name	Related models	Description	Part No.
	Flat bucket set	DCU603, DCU604, DCU605	Includes Flat bucket and Flat bucket base. (equipped with a capped nozzle for draining liquid) Bucket capacity: 295L (Heaped capacity)	1911B3-6
	Dump unit set	DCU603, DCU604, DCU605	Damp unit for Pipe frame carrier or Dump bucket 200	1914G7-1
	Carrier set	DCU602, DCU603, DCU604, DCU605	Pipe frame carrier, Variable-size loading platform Frame size (L x W): 625-1,015mm x 945-1,090mm	*191B67-2
	Dump bucket 200 set		Loading platform of dump bucket type Bucket capacity: 200L (Heaped capacity)	*191B69-8
	Bucket set	DCU180	Loading platform of dump bucket type Bucket capacity: 90L	198494-2
				199008-0 (EU)
	Carrier set		Pipe frame carrier, Variable-size loading platform Frame size (L x W): 850mm x 660-980mm	199009-8 (EU) 199116-7

Wheelbarrow wheel

Still photo	Name	Related models	Description	Part No.
	Tire 330 (single) set	DCU601, DCU602, DCU603, DCU604, DCU605	For lawn and pavement	1911K4-7
	Gray tire 330 (single) set	DCU601, DCU602, DCU603, DCU604, DCU605	For use in industrial sites, such as factory, where black tire marks on the floor are undesirable.	1911K5-5
	Gray tire 210 (single) set	DCU601, DCU602, DCU603, DCU604, DCU605	For use in industrial sites, such as factory, where black tire marks on the floor are undesirable.	1911K6-3
	Auxiliary wheel attachment set	DCU180		191A01-6

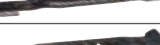

Standard blade

Still photo	Name	Related models	Cutting width (mm)	Part No.
	Blade 330	DLM330	330	GB00000042
	Blade 380 set	LM003G	380	1913G8-3
		DLM382		191D41-2
	Blade 430 set	LM004G	430	1913H4-8
		DLM432	430	191D43-8
				197761-2
	Blade 460 set	DLM460, DLM463	460	199367-2
		DLM462, DLM465		191D51-9
	Blade 480 set	DLM480, DLM481, LM001G, LM001J, LM003J	480	191V97-3
	Blade 530 set	DLM530, DLM532, DLM533, DLM534, DLM536, DLM537, LM001C, LM002G, LM004J	530	191D52-7
				191V96-5







Collecting grass blade

Still photo	Name	Related models	Cutting width (mm)	Part No.
	Blade 460 set	DLM460, DLM463	460	1910N1-8
				191W86-4
	Blade 530 set	DLM530, DLM532, DLM533, DLM534, DLM536, DLM537, DLM538, DLM539, LM001C, LM002G, LM002J, LM004J	530	191W87-2

Mulching blade

Still photo	Name	Related models	Cutting width (mm)	Part No.
	Mulching blade 380 set	LM003G	380	1913H0-6
	Mulching blade 430 set	LM004G	430	1913H6-4
	Blade 460 set	DLM462, DLM465, DLM466	460	191Y63-8
	Blade 480 set	DLM480, DLM481, LM001G, LM001J, LM003J	480	191Y64-6
	Blade 530 set	DLM530, DLM532, DLM533, DLM534, DLM536, DLM537, DLM538, DLM539, LM001C, LM002G, LM002J, LM004J	530	191Y65-4

Swing back blade





Swing back blade complete					Replacement blade set		
Still photo	Name	Cutting width (mm)	Related models	Part No.	Still photo	Par pkg.	Part No.
	Swing back blade 460 complete set	460	DLM462, DLM465	191D49-6		4	191D47-0
	Swing back blade 480 complete	480	LM001G, LM003J	1911B0-2		4	1911P1-8
	Swing back blade 530 complete set	530	DLM530, DLM532, DLM533, DLM536, DLM537, LM001C, LM002G, LM004J	191D50-1		4	191D48-8

Outdoor Power Equipment

Robotic Mower Blade

Still photo	Name	Related models	Description	Part No.
	Blade set G	RM350D	Blade 9pics, Special screw: 9pics set	1913M9-3

Accessory for robotic mower

Still photo	Name	Related models	Description	Part No.
	Wire 150m set G	RM350D	For laying the boundary and guide wires. Copper-covered [copper-clad] aluminum 150m	1913N2-4
	Wire 50m set G		For laying the boundary and guide wires. Copper-covered [copper-clad] aluminum 50m	1913Y3-9
	Wire repair set G		Wire 5M, Joint Coupler 6pics and Peg 10pics set	1913N4-0
	Peg set G		50pics set	1913N6-6
	Terminal block set G		5pics set	1913N8-2

Mulching plug set for lawn mower

Still photo	Name	Related models	Part No.
	Mulching plug 380 set	LM003G	1913H2-2
	Mulching plug 430 set	LM004G	1913H8-0
	Mulching plug set	DLM382, DLM432	191D46-2
	Mulching plug 530	DLM538, DLM539, LM002J	413945-7
	Mulching plug 480	DLM480, DLM481, LM001J	413946-5

Dethatching blade

Still photo	Name	Related models	Part No.
	Dethatching blade set	UV001G	1913J7-6
		DUV320, UV320	YA00001317
		UV3600	652024749







Scarifying blade

Still photo	Name	Related models	Part No.
	Scarifying blade set	UV001G	1913J5-0
		DUV320, UV3200	YA00001316
	Combination	UV3600	652024746 652024750

Machine grease

Still photo	Name	Related models	Capacity(g)	Part No.
	Grease vessel set	DUH501, DUH502, DUH506, DUH601, DUH602, DUH604S, DUH606, DUH751, DUH752, DUH754S, DUR369A, DUR369L, DUR369N, DUX60, UH004G, UH005G, UH006G, UH007G, UH008G, UH009G, UH013G, UH014G, UN001G, UR006G, UR007G, UR008G, UR016G, UR017G, UR101C, UR201C, UR202C	85	199450-5

Pump adapter

Still photo	Name	Related models	Part No.
	Swim ring adapter	DMP180, DMP181, MP001G, MP100D	TE00000333
	Ball adapter		TE00000592
	French adapter		TE00000594
	British valve adapter	DMP180, MP100D	TE00000597
	Air chuck	DMP181, MP001G	TE00000796
			TE00000691



FILTER SET

Still photo	Name	Related models	TYPE	Part No.
	Filter set	DFV214A, DFV215A	NON-WOVEN	198641-5
	Filter (20 pcs)			198642-3
				198643-1







Lamp shade

Still photo	Name	Related models	Part No.
	Lamp shade	ML107	GM00002476
		DML809	GM00002286
		DML811	GM00002287
		DML816, ML006G	GM00001326
		ML005G	GM00002358
		ML009G	GM00002377
		DML817, ML011G	GM00002457

Anti-glare film

Still photo	Name	Related models	Part No.
	Anti-glare film	ML003G	GM00002312
		ML005G	GM00002359
		ML009G	GM00002376

Strap

Still photo	Name	Related models	Part No.
	Strap	DML812	GM00002239
		ML104	GM00001028
		DML817, ML011G, ML107	SE00001178
		ML012G, DML818	GM00002544
	Hand strap with metal strap ho	ML007G	GM00002373
	Hook band set	ML001G	GM00002280
	Shoulder hook set	ML006G, DML816	GM00001288



Telescopic hook for flashlight

Still photo	Name	Related models	Part No.
	Telescopic hook	ML012G, DML818	GM00002545

Magnet





Still photo	Name	Related models	Part No.
	Magnet attachment	ML105, ML104	GM00001714

Accessory for vacuum pump





Still photo	Name	Related models	Part No.
	Hose packing (6 pcs)	DVP180	AS000AI158
	Vacuum gauge		AS00XP808M
	Vacuum hose		AS0AI154MK
	Vacuum pump oil	DVP181	AS0VP083MK
	Adapter	DVP180, DVP181	AS0Y06110K

Others

Flexible shaft

Still photo	Name	Related models	Part No.
	Flexible shaft 32-1.2 set	VR001G, VR003G, VR004G	1910E1-5
	Flexible shaft 38-1.2 set		1910E3-1
	Flexible shaft 32-1.7 set		1910E2-3
	Flexible shaft 32-2.4 set		1910C2-9
	Flexible shaft 38-2.4 set		1910C4-5













Battery case

Still photo	Name	Related models	COMPATIBLE BATTERY	Part No.
	Battery case L set	VR001G, VR003G, VR004G	XGT 5AH>=	1910J1-0
		VR003G		1910J2-8
	Battery case H set	VR001G, VR003G, VR004G	XGT 4AH<=, PORTABLE POWER PACK	1910J4-4
		VR003G, VR004G		1910J5-2

Mixing blade



*With Bolt & Nut M8

Still photo	Mixing Blade			Bolt		Shaft			Model
	Size	Material	Part No.	Bolt Size	Part No.	Bolt size of Power Mixer	Size	Part No.	
	130mm	INOX	A-43670	M8 x 18	265220-5	M12	L=584mm D=12mm	168349-5	DUT130, UT1305 UT001G
	133mm		A-68862	M8 x 18	265220-5	M12	L=584mm D=12mm	168349-5	DUT130, UT1305
	135mm	Aluminum	A-43723	W5/16 x 16	265475-2	M12	L=584mm D=12mm	A-43773	DUT130, UT1305 UT2204, UT001G
	150mm	INOX	*A-43686	-	-	M12	L=584mm D=12mm	168349-5	DUT130, UT1305 UT2204, UT001G
	165mm		A-43692	M8 x 18	265220-5	M12	L=584mm D=12mm	168349-5	DUT130, UT1305 UT001G
			A-57906	M8 x 18	265220-5	M12	L=584mm D=12mm	168349-5	DUT130, UT1305
	175mm	Aluminum	136865-5	M8 x 16	265440-1	M12	L=584mm D=12mm	A-43773	UT001G
	183mm		A-43739	W5/16 x 16	265475-2	M12	L=584mm D=12mm	A-43773	DUT130, UT1305 UT001G
	190mm	Steel	A-33065	W5/16 x 16	265475-2	M12	L=584mm D=12mm	A-43773	UT2204, UT001G
	201mm		A-33071	W5/16 x 16	265475-2	M12	L=584mm D=12mm	A-43773	UT2204, UT001G
	220mm	Aluminum	A-43717	*M8 x 16	265440-1	M12	L=584mm D=12mm	A-43773	UT2204, UT001G
	175mm		136865-5	*M8 x 16	265440-1	M12	L=584mm D=12mm	A-43773	UT001G

Accessory for grease gun



Still photo	Name	Related models	Barrel		Max operating pressure (mpa)	Description	Part No.	
			Type	Capacity (g)				
	Cartridge barrel assembly A set	DGP180	A	400	-	with barrel holder	1910T3-6	
	Cartridge barrel assembly B set		B	450	-	with joint A	1910T4-4	
	Cartridge barrel assembly C set		C	500	-	with joint A	1910T5-2	
	Cartridge barrel assembly C set		C	500	-	-	1910T6-0	
	Cartridge barrel A set		A	400	-	Barrel only	191F24-4	
	Cartridge barrel B set		B	450	-		1910X4-2	
	Cartridge barrel C set		C	500	-		191F27-8	
	Barrel assembly A set		A	400	-	with barrel holder	Bulk grease is directly loadable into the barrel. Not only grease cartridges but also bulk grease in pail can be loaded direct into the barrel.	1910X0-0
	Barrel assembly B set		B	450	-	with joint A		1910X1-8
	Barrel assembly C set		C	500	-	with joint A		1910X3-4
	Barrel assembly C set		C	500	-			1910T7-8
	Extension pipe set		-	-	-	Length : 160mm		1911M9-1
	Loader fitting set		-	-	-	Grease is pumped from a pail to lubricate machinery.		1914G9-7
	Lock on adapter set		-	-	-	Locking grease coupler for a more secure connection to the grease nipple of a machine to be lubricated		1915N4-2
	Angle adapter set		-	-	69	90° grease coupler for hard-to-reach grease nipples		191A77-3
	Flexible hose 1200 set		-	-	69	NPT1/8, Length : 1.2m, with Adapter		191W58-9
	Flexible hose 600 set		-	-	69	NPT1/8, Length : 0.6m, with Adapter		191W59-7
	Adapter set (3 pcs)		-	-	69	NPT1/8 Grease coupler to connect the exhibe hose to the grease nipple of a machine to be lubricated.		191W60-2
	Adapter set (1 pc)	-	-	69			191W61-0	

Holder for caulking gun







Still photo	Name	Related models	Capacity (ml)	Type	Description	Part No.
	Holder A set	CG100D, DCG180	300	A	Cartridge type For Bonding of external wall, window frame, For Water section and Interior nishing	196351-8
	Holder B set		600	B	Cartridge type / Sausage type / Bulk sealant type For Sealing work with two-component system, For Tile bonding	1911T4-0
	Holder C set		800	C	Cartridge type / Sausage type For continuous work with a thick Cartridge/ Sausage sealant	197195-9
	Holder D set		400	D	Cartridge type / Sausage type / Bulk sealant type For Sealing work with two-component system, For Tile bonding	1911T5-8

Others

Battery protector

Still photo	Name	Related models	Part No.
	Cover L set	UT001G, UT002G	1911R6-2
	Battery protector set	DDA350, DDA351, DDF451, DDF453, DHP451, DHP453, DHR202, DTD152, DTD153, DTD154, DTD173, DTL061, DTL063, DTS141, DTW251, DTW253, DTW450, LM002J	194649-7
		DDF458, DHP458, LM002J	195798-3

Battery adapter & Battery converter

Still photo	Name	Related models	Part No.
	Battery adapter set	BO001CG, BO002CG, BO003CG, BO004CG, BO005CG, BO006CG	1914H3-6
			1914H5-2
		BO002CG, BO003CG	1914N4-6
			1914N5-4
	Interchangeable adapter ADP10 set	Model ADP10 is an interchangeable adapter developed for use with XGT charger to charge LXT Li-Ion batteries.	191C10-7
			191C11-5



Harness for battery adapter

Still photo	Name	Related models	Part No.
	Harness set	BO001CG, BO002CG, BO003CG, BO004CG, BO005CG, BO006CG	1914H8-6

Cigar socket cable

Still photo	Name	Related models	Part No.
	Cigar lighter dc 12-24V	CW001G, CW003G, DCW180	WL00000002
		DCW180	WL00000139
	Cigar lighter	CW002G	WL00000225
		CW004G	CE00000007

Battery communication connector

Still photo	Note	Related models
	App for iOS/Android[Bluetooth/BLE] Windows[via USB (Type C)]	ADP12
	App for Windows[via USB (Type C)]	ADP13

Shoulder strap













Still photo	Name	Related models	Part No.
	Ring set	DTW1004	1913P0-2
		TW001G	191M83-0
	Tool catcher set (with strap)	DTW251, DTW300, DTW301, DTW302	197941-0
	Shoulder strap set	DSC102, SC103D	199069-0
	Shoulder belt set	DVC750L	199486-4
		CW004G	A-76956
	Shoulder belt	DML813, DML814	TD00000002

Tool catcher

Still photo	Related models	Part No.
	DHR183, HR010G	1911K0-5
	HR3001C, HR3011FC, HR3012FC	191F45-6
	TD001G	191F58-7
	DTW300, DTW301, DTW302, TW004G, TW005G	191K57-9
	DTD153, DTD154, DTD157, DTD173	197043-2
	DTW190, TW202D	197940-2
	DHR182	199593-3

















Heat gun accessories



For Model	Shape	Part No.
DHG181, DHG180, HG6031V, HG6030, HG5030, HG6530V, HG6531C	Glass protection nozzle 	PR0000028
	Wide-slot nozzle 	PR0000029
	Reflector nozzle 	PR0000030
	Reduction nozzle 20 	PR0000031
	Overlap welding nozzle 	PR0000032
	Solder sleeves reflector 	PR0000033
	Welding nozzle 	PR0000034
	Pressure roller 	PR0000035
	Scraper 	PR0000040
	Scraper set 	PR0000041
	Scraper 	PR0000042
	HG6031V, HG6030, HG5030, HG6530V, HG6531C	Welding rods 
Speed welding nozzle 		PR0000039

Rechargeable Green Multi Line Laser accessories

*Thread size: W5/8

Model No.	Shape	Part No.
SK312GD, SK209GD, SK700GD, SK700D, SK106D/GD, SK105D/GD	Mini tripod *Thread size: W5/8 	TK0LM2000F
	Tripod 1800 *Thread size: W5/8 	TK0LM4001F
	Tripod 2900 *Thread size: W5/8 	TK0LM5030F
SK40GD, SK20GD, SK10GD	Mount 	TK00ET03F1
	SK700DGD, SK106D/GD, SK105D/GD 	LE00870137
SK312GD, SK209GD	Power supply cable USB Type A 	199006-4
SK106GD, SK105GD		199178-5
SK312GD, SK209GD SK106GD, SK105GD	Hand strap set 	199007-2
	Adapter for USB 	ADP05
SK106D/GD, SK105D/GD SK700D/GD	Laser Receiver LDX1 	LE00855702
SK312GD, SK209GD	Laser Receiver LDG-3 	TK0LDG301F
SK40GD, SK20GD, SK10GD, SK312GD, SK209GD	Laser Receiver LDG-5 	TK0LDG501F
SKR001	Remote RC1 	LE00981929
	LDx2 digital rotary laser receiver set 	LE00981928
	Wall mount for rotary laser, metal 	LE00981930
HG6031V, HG6030, HG5030, HG6530V, HG6531C	CXT battery tray 	LE00981911
	XGT battery tray 	LE00981913

Others

Battery adapter & Battery converter

PDC01



BAP182



BCV01



BCV03



Type	Battery type	For Model
PDC01	LXT 18V Battery x4	LXT 18V Models or LXT 18Vx2 Models or Direct connection 36V Models
BAP182	LXT 18V Battery x2	LXT 18Vx2 Model
BCV01		Old 36V Models
BCV03		
BAP18 BAP18C	LXT 18V Battery	LXT 18V

Harness for BAP182/BCV01

Harness

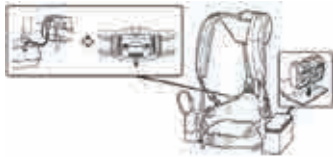

Shoulder Belt



Type	Part No.
Harness	196818-6
Shoulder Belt	162523-7

String trimmer harness for PDC01 / PDC1200 / PDC1500



Item	Part No.
A	191E43-4
B	197243-4

Blower harness for PDC01 / PDC1200/ PDC1500

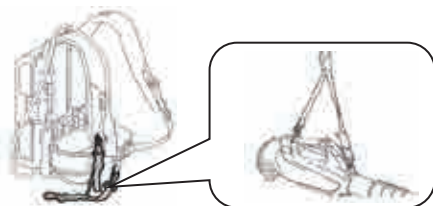

Part No.
191J48-4

Battery adapter for PDC01 & LXT 18V Battery models



Part No.
191A53-7

Battery adapter for PDC01, PDC1200, PDC1500 & XGT 40V Battery models



Part No.
191N62-4

Battery adapter for PDC01, PDC1200, PDC1500 & LXT 18Vx2 Battery models



Part No.
191J51-5
191A52-9

Portable Battery Checker

*BTC04 is also necessary
*With SD card for BTC04 software update.

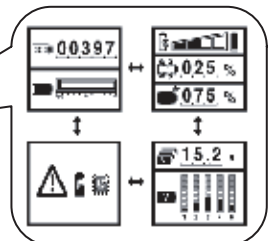

Your PC and your USB cable



Checking time: 3-5sec.

Battery type	Battery Checker	market	Parts No.
Except XGT, CXT, G battery, BL6440, BL64100, BL3622A, BL36120A, PDC1200, PDC1500	BTC04	-	198038-8
		-	198200-5
		CANADA U.S.A.	198199-4
XGT battery	*BTC05	-	191K30-9
CXT battery	BTC06	-	-
PDC1200, PDC1500 BL6440, DL64100	*BTC07	-	191Y78-5

Battery Timer Setting Adapter

The Battery Timer Setting Adapter provides an anti-theft solution for Makita-brand battery cartridges by utilizing the mobile devices or PCs (with the dedicated app installed) required for timer setup.

Applicable lithium-ion battery

- BL1430B BL1460B
- BL1820B BL1830B BL1840B BL1850B BL1860B

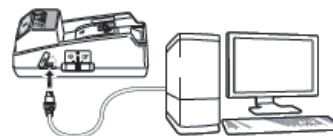

Part No.
BP501

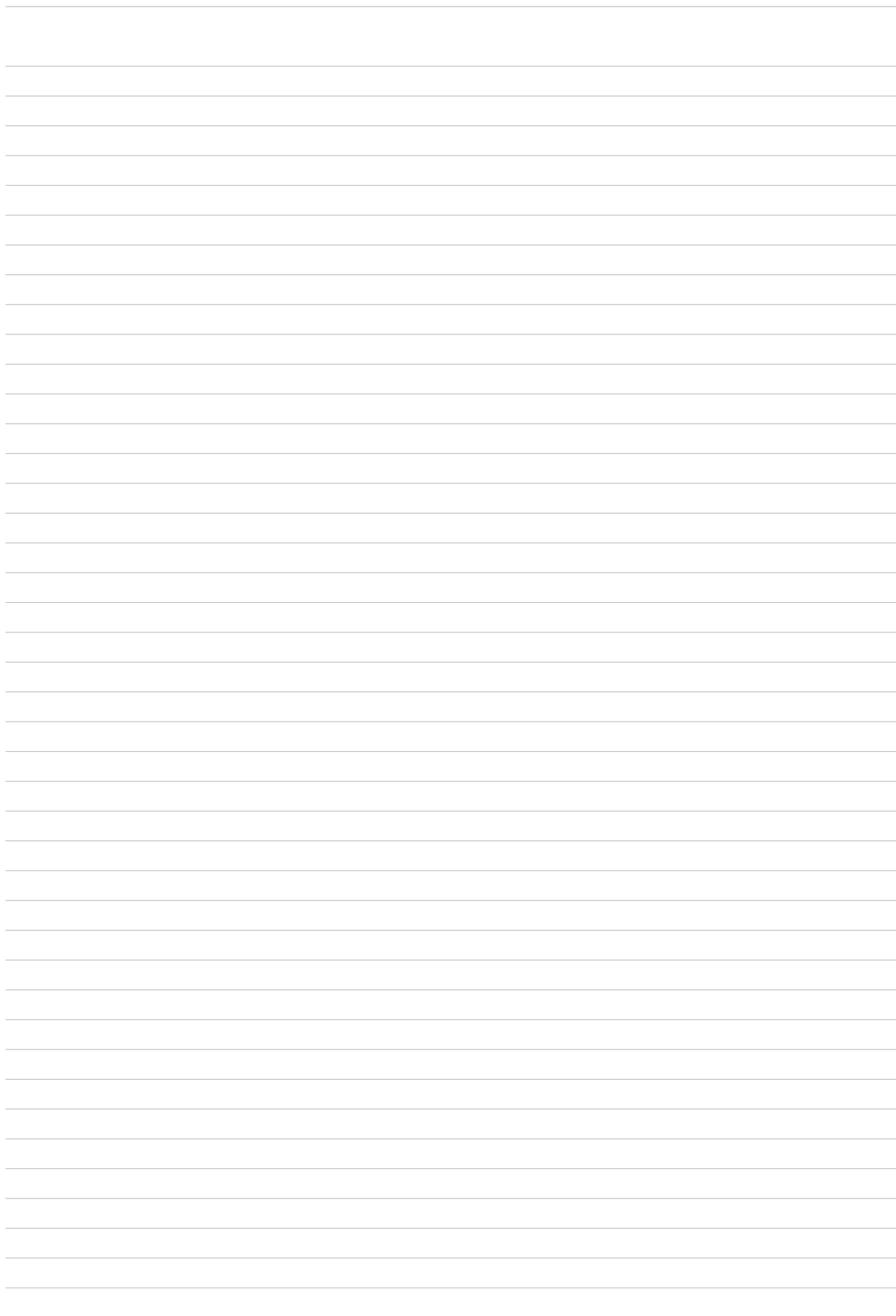

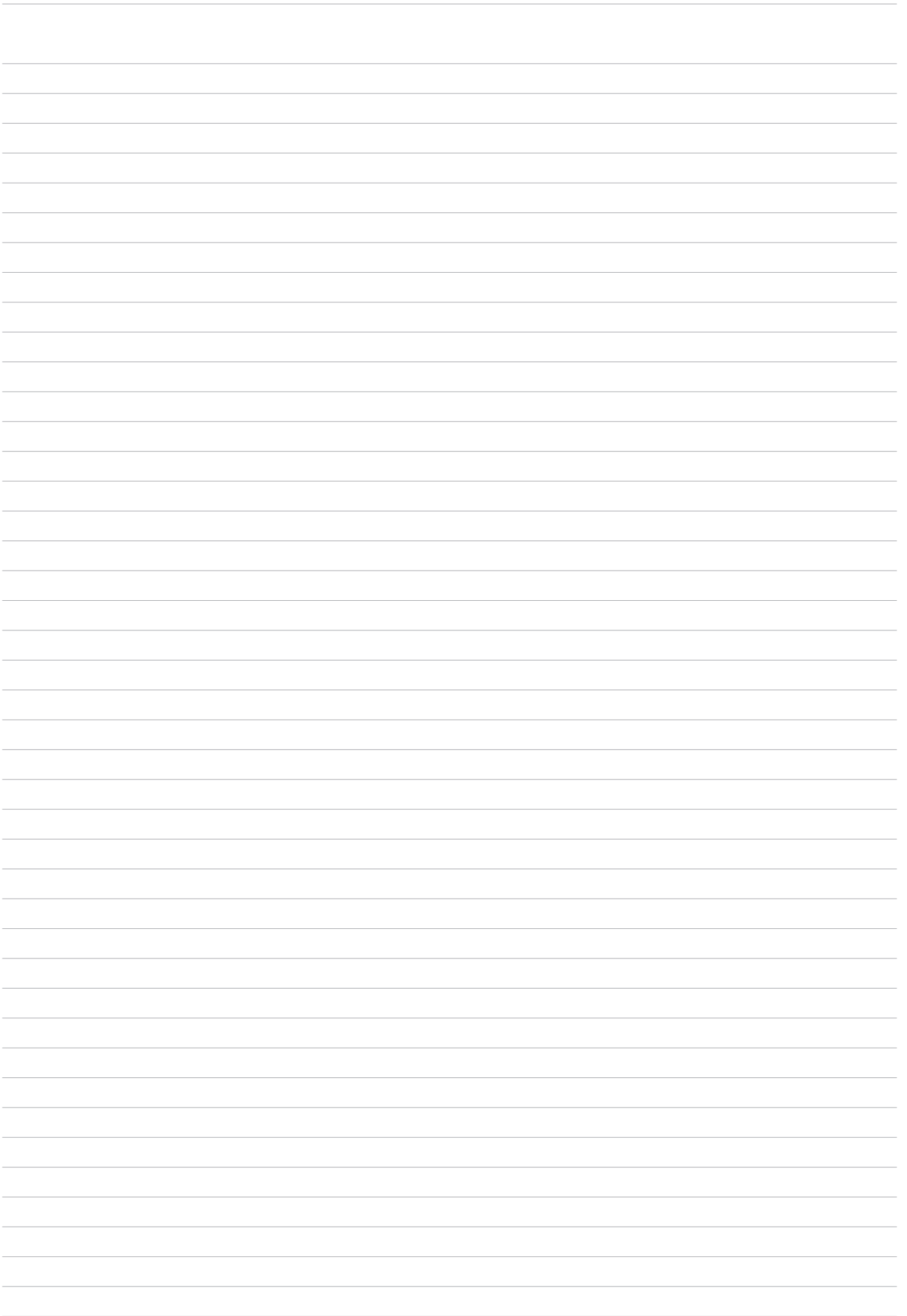

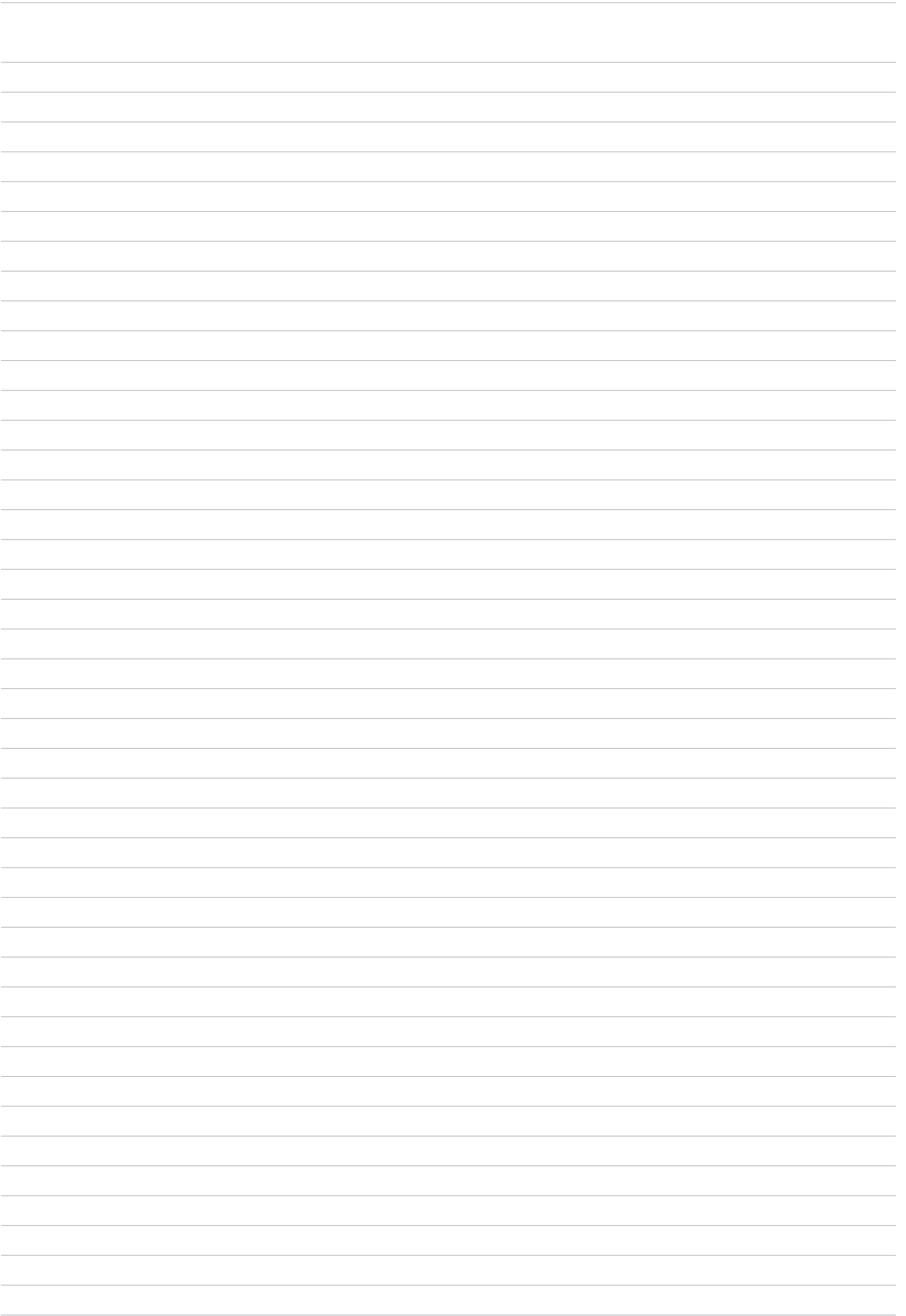

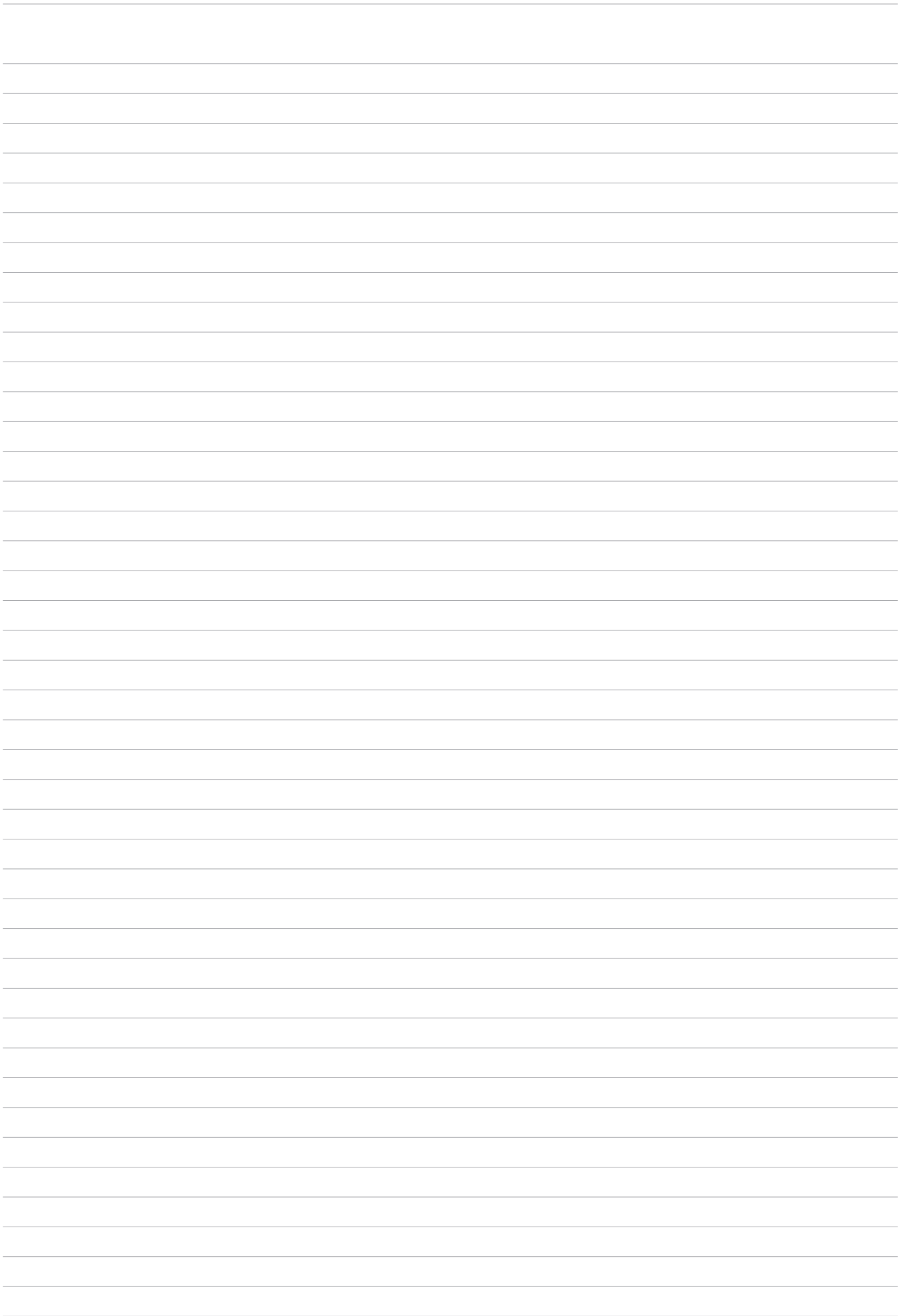

Makita - A Global Brand

Makita have established directly operated business bases in about 50 countries around the world, and have upgraded our sales network in over 170 countries and after-sales service capabilities to become one of the leading companies in our industry. In addition, Makita is producing power tools and OPE in China, Romania, Thailand, U.K., Brazil, U.S. and Germany. Currently, about 90% of our group's manufacturing work in terms of production volume is carried out overseas.

Makita's worldwide sales and service network, as well as the stable, high production quality ensured at its plants worldwide, are the embodiment of the Makita brand.

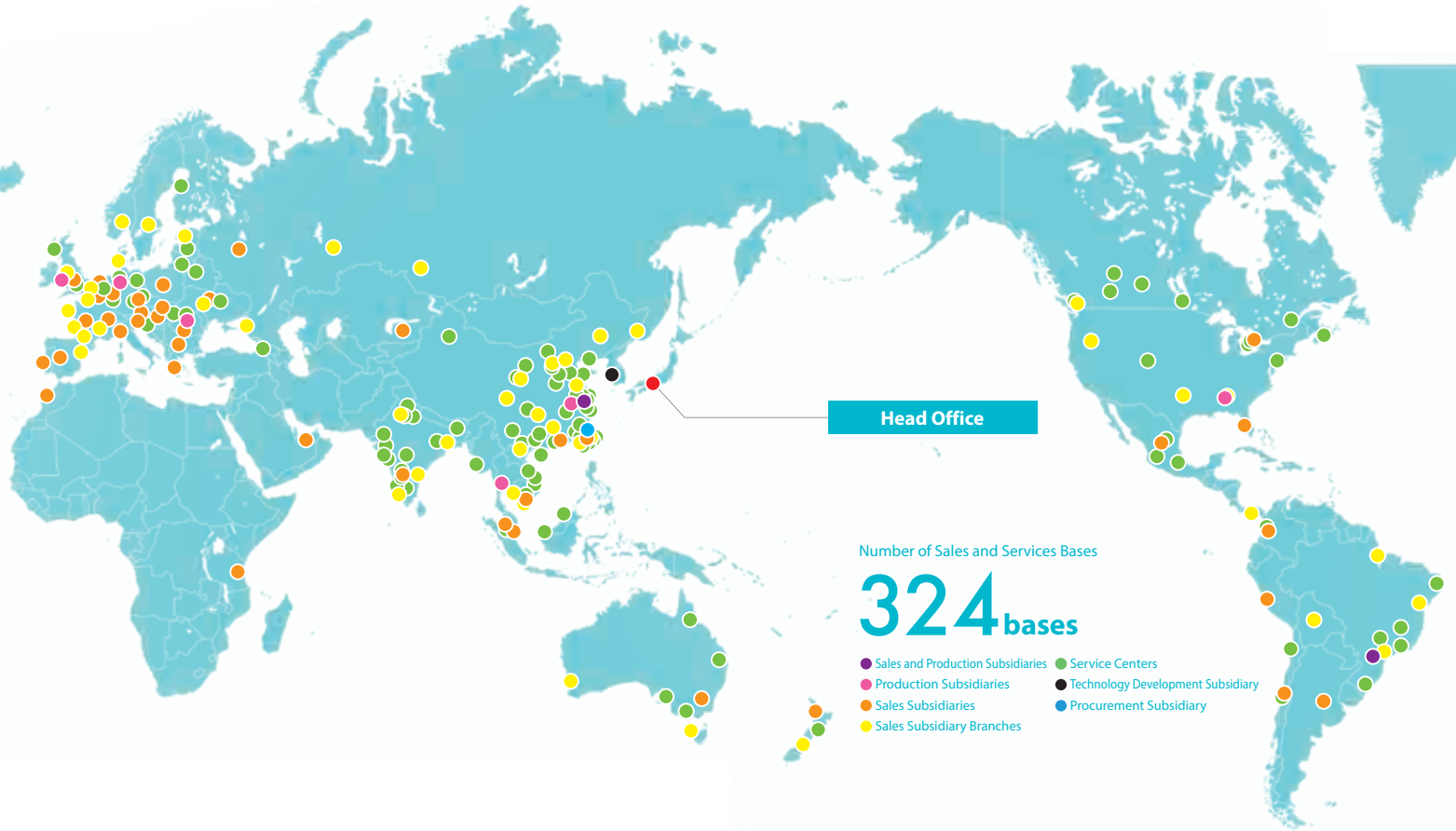

JAPAN

Makita Corporation Headquarters



JAPAN

Okazaki Plant



U.S.A.

U.S. Plant



UNITED KINGDOM

U.K. Plant



ROMANIA

Romania Plant



GERMANY

Germany Plant



BRAZIL

Brazil Plant



CHINA

China Plant (MCC)



CHINA

China Plant (MKC)



THAILAND

Thailand Plant



JAPAN

Makita Corporation

Head office
3-11-8, Sumiyoshi-cho, Anjo, Aichi
446-8502
Phone: +81-(0)566-98-1711
Fax: +81-(0)566-98-6021
www.makita.co.jp

Okazaki plant

22-1, Watarijima, Nemunoki-cho,
Okazaki, Aichi 444-0232
Phone: +81-(0)564-43-3111

Nisshin Office

349 Minamiyama,
Komenoki-cho, Nisshin,
Aichi 470-0111
Phone: +81-(0)561-75-1500

Tokyo branch office

3-5-3, Hongo, Bunkyo-ku,
Tokyo 113-0033
Phone: +81-(0)3-3816-1141
Fax: +81-(0)3-3813-1633

Nagoya branch office

2-33, Namiki, Nakamura-ku,
Nagoya 453-0856
Phone: +81-(0)52-419-0561
Fax: +81-(0)52-413-0081

Osaka branch office

1-26-8, Tenma, Kita-ku,
Osaka 530-0043
Phone: +81-(0)6-6351-8771
Fax: +81-(0)6-6352-4607

Domestic sales offices

Sapporo, Sendai, Niigata, Utsunomiya,
Saitama, Chiba, Yokohama, Shizuoka,
Gifu, Kanazawa, Kyoto, Hyogo, Okayama,
Hiroshima, Takamatsu, Fukuoka,
Kumamoto, Okinawa and other major
cities

CHINA

Makita (China) Co., Ltd.

Head office & plant (MCC)
No.1388 Middle Huangpujiang Road,
Kunshan Economic & Technical
Development Zone, Jiangsu, China
Postcode: 215335
Phone: +86-(0)512-57707710
Fax: +86-(0)512-57713623
www.makita.com.cn

Domestic sales department (MCS/MCCF)

No.318, South Wusongjiang Road,
Kunshan City, Jiangsu, China
Postcode : 215300
Phone: +86-(0)512-57037500
Fax: +86-(0)512-57037118
www.makita.com.cn

Domestic sales department (MCCS)

No.80 Meigui Road, Kunshan Economic
& Technical Development Zone, Jiangsu,
China
Postcode : 215300
Phone: +86-(0)512-57567710

Guangzhou sales branch (CGZ)

Rome 1001 1002, The First Floor, Jinhao
Building, No.38, Middle Of Huadi
Avenue, Li Wan
District, Guangzhou, Guangdong, China
Postcode : 510380
Phone: +86-(0)20-87518872
Fax: +86-(0)20-87518873

Shanghai sales branch (CSH)

Room.102&103, 1F, No.128, East Luoxiu
Road, Xuhui District, Shanghai, China
Postcode : 200231
Phone: +86-(0)21-54487198
Fax: +86-(0)21-62476732

Tianjin sales branch (CTJ)

No.3 Office Building, No.23, Quanwang
Road, Wuqing Development
Area, Tianjin, China
Postcode : 301700
Phone: +86-(0)22-29395799
Fax: +86-(0)22-29395769

Chengdu sales branch (CCD)

2F, Building 1, Hatchery Building, No.9, Wu
Ke Dong San Road, Wu Hou
District, Chengdu, Sichuan, China
Postcode : 610045
Phone: +86-(0)28-85366002
Fax: +86-(0)28-87337018

Shenyang sales branch (CSY)

No.27, Shenxin East Road, TieXi District,
Shenyang, Liaoning, China
Postcode : 110000
Phone: +86-(0)24-22530648
Fax: +86-(0)24-22530170

Xian sales branch (CXA)

1 & 2F, Xian Youzhi Science and Technology
Industrial Park NO.75 Mingguang Road,
Economic And Technological Development
Zone, Xian, Shanxi, China
Postcode : 710018
Phone: +86-(0)29-86223736
Fax: +86-(0)29-86229230

Changsha sales branch (CCS)

(Near Gaosheng Road) No.3, Building
5, Youxin Mechanical And Electrical
Market, Yuhua District, Changsha, Hunan,
China
Postcode : 410114
Phone: +86-(0)731-8526-7792
Fax: +86-(0)731-8526-7791

Shijiazhuang sales branch (CSJ)

No.102, 1F, 2nd Plant, No.403, Yuhua
East Road, Yuhua District,
Shijiazhuang, Hebei, China
Postcode: 050000
Phone: +86-(0)311-85258508
Fax: +86-(0)311-85024612

Makita (Kunshan) Co. Ltd.

No.1, Nanzi Road, Kunshan Economic &
Technical Development Zone,
Jiangsu, China
Postcode: 215300
Phone: +86-(0)512-57367367
Fax: +86(0)512-57365575

Makita Power Tools (HK) Limited

Head office
Unit 1, 17/F., Grandtech Centre,
8 On Ping Street, Shatin, N.T., Hong Kong
Phone: +852-2648-8683
Fax: +852-2648-5237

Macau Service Centre

Em Macau, Rua Do Volong N°11,
Rés-Do-Chão A
Phone: +853-2835-4587
Fax: +853-2835-4135
www.makita.com.hk

Makita (Taiwan) Ltd.

Head office
No.798, Sec. 2, Wenhua 3rd Rd.,
Linkou Dist., New Taipei City 24459,
Taiwan
Phone: +886-(0)2-8601-9898
Fax: +886-(0)2-8601-2266
www.makita.com.tw

Taichung sales branch

No. 839, Section 3, Zhongqing Rd, Daya
Dist, Taichung City, 428, Taiwan
Phone: +886-(0)4-2392-1650
Fax: +886-(0)4-2392-1653

Kaohsiung sales branch

No.105, Yucheng Rd., Sanmin Dist.,
Kaohsiung City 807, Taiwan
Phone: +886-(0)7-343-0292~4
Fax: +886-(0)7-341-3602

Yilan factory service center

No. 237, Section 3, Chuanyi Rd, Luodong
Township, Yilan County, 265, Taiwan
Phone: +886-(0)3-956-7801
Fax: +886-(0)3-956-7877

Hualien factory service center

No.247, Sec.2, Zhongyang Rd.,
Ji'an Township, Hualien County 973,
Taiwan
Phone: +886-(0)3-852-8901
Fax: +886-(0)3-852-8515

Yunlin factory service center

No.197, Guangfu Rd., Huwei Township,
Yunlin County 632, Taiwan
Phone: +886-(0)5-632-8200
Fax: +886-(0)5-632-8190

Tainan factory service center

No. 182, Minzhi Rd, Xinying District,
Tainan City 730, Taiwan
Phone: +886-(0)6-656-5651
Fax: +886-(0)6-656-7800

Pingtung factory service center

No.12&16, Ruimin Rd.,
Pingtung City 900, Taiwan
Phone: +886-(0)8-722-0001
Fax: +886-(0)8-722-0733

Taitung factory service center

No. 51, Section 2, Zhongxing Rd, Taitung
City, Taitung County 950, Taiwan
Phone: +886-(0)89-232-301
Fax: +886-(0)89-232-322

SINGAPORE

Makita Singapore Pte. Ltd.

Head Office
7, Changi South Street 3, Singapore 486348
Phone: +65-6546-8700
Fax: +65-6546-8711
www.makita.com.sg

Myanmar Service Center

No.D36/2, Lan Thit Road, Insein Township, Yangon.
Phone: +95-(0)9-76232-6433
+95-(0)9-76911-5388

Cambodia Service Center

No. 432, Street 271, Phum Chamroeun
Phal 4, Sangkat Boeung Tumpun 1, Khan
Meanchey, Phnom Penh, CAMBODIA.
Phone: +855-(0)78-994-071
https://www.makita.com.kh/

INDIA

Makita Power Tools India Pvt. Ltd.

Head Office
Unit 2, Sy. No. 93/3 & 93/4,
Koralur Village, Kasaba Hobli,
Hoskote Taluk, Bangalore – 560067.
India.
Phone: +91-(0)80-2205-8200
Fax: +91-(0)80-2854-9007
www.makita.in

Delhi Branch

Khasra No. 1035, Village Mundka, Near
Ganapati Dharam Kanta, Delhi – 110041,
India
Phone: 011-28341102

Chennai Branch

No.30, Jawaharlal Nehru Salai,
Koyambedu, Chennai – 600107. India.
Phone: +91-(0)44-2479-2522
Fax: +91-(0)44-2479-2533

Kolkata Branch

P-46, Hide Road Extension,
Kolkata – 700088.
West Bengal, India.
Phone: +91-(0)33-2439-1030 / 1060

Cochin Branch

Door No. XVI/443A, Jubilee Road, Kerala –
682040. India
Phone: +91-8590432003

Mumbai Service Centre

Shop No.3, on Ground Floor,
Commercial Chamber, bearing
Municipal Street No.76, and 72/80,
Nagdevi Cross Lane, Mumbai 400003.
Phone: +91(0)22-4974-4092

Ahmedabad Service Centre

Aniket Estate, Near Sawan Hotel, Near
Sarkhej – Sanand Chokdi, S. G. Highway,
Ahmedabad – 382210. India.
Phone: +91-6358737996

Peenya Service Center

No. 36/B, F1, 2nd Phase, 1st Main Road,
KIADB, NTTFC Circle, Peenya Industrial
Area, Bangalore - 560058
Phone: +91-9606980302

Pune Service Centre

Shop No. 104, First Floor, Plot No.
PAP/J/121/122. J Block, MIDC Bhoasari,
Pimpri Chinch Wad, Pune - 411026
Phone: 020-46300061

Rudrapur Service Centre

MIG-48, Ground Floor, Ward No. 19, New
Ward no. 38, Near Siddhu Palace, Awas
Vikas, Rudrapur, Uttarakhand - 263153
Phone: +91 7042597756

Jamshedpur Service Centre

Shop no. 24, Shivaranjani Complex, Plot
no. ST-8, Mouzadindli, Adityapur,
P.S.Adityapur Ward no. 5, Saraikel (D),
Kharswan, Jharkhand state, 831013
Phone: 0657 - 2383024

Indore Service Centre

Unit No. B-34, Block No. B-18, Access B,
New Siyaganji, Poddar Plaza, HTL, Unit 2,
VIP Route No.1, Kachhi Mohalla, Indore
,452007
Phone: 0731-3593608

Vadodara Service Centre

Shop No. 3, Lakod Complex, GIDC,
Makarpura, Vadodara, 390010, Gujarat
Phone: Mob. +91 88665 53756

Guwahati Service Centre

Sahani Mansion, Chatribari Road,
Guwahati, Kamrup Metropolitan,
Assam - 781001, India.
Phone: 036-13514572

Coimbatore Service Centre

D.No.138/6, Ground Floor, Rangankar Street,
Katoor, Coimbatore - 641009, Tamilnadu.
Phone: 0422-3510235

VIETNAM

Makita Vietnam Co. Ltd.

Head office
Unit 4-5-6, Block 16 18 L1-2, Street 3,
VSIP II Industrial Park, Hoa Phu Ward,
Thu Dau Mot City, Binh Duong Province,
Vietnam.
Phone: +84-274-362-8338
Fax: +84-274-362-8339
www.makita.com.vn

North Branch

Unit 05, No.01, Street 6, VSIP Bac Ninh
Intergrated Township and Industrial
Park, Phu Chan Ward, Tu Son Town, Bac
Ninh Province, Vietnam
Phone: +84-222-376-5942
Fax: +84-222-376-5941

Da Nang Service Center

40 Chi Lang Street, Hai Chau II Ward, Hai
Chau District, Da Nang City, Vietnam
Phone: +84-236-352-5079
Fax: +84-236-352-5479

Can Tho Service Center

366 Vo Van Kiet Street, 5 Zone, An Thoi
Ward, Binh Thuy District, Can Tho City,
Vietnam.
Phone: +84-292-389-4358
Fax: +84-292-389-4359

Buon Ma Thuot Service Center

68 Le Duc Tho, Thang Loi Ward, Buon Ma
Thuot City, Dak Lak Province, Vietnam
Phone: +84-262-355-4556
Fax: +84-262-355-4557

ASIA

Hai Phong Service Center

No. 01 Lot OH-01, Huy Hoang Riverside project, Thuong Ly Ward, Hong Bang District, Hai Phong City, Viet Nam
Phone: +84-225-883-1429/1529

Nha Trang Service Center

Lot 36-38, Road B6, Vinh Diem Trung Urban Area, Vinh Ngoc Ward, Nha Trang City, Khanh Hoa Province, Viet Nam
Phone: +84-258-220-0079

Ho Chi Minh Service Center

12 Trinh Van Can, Cau Ong Lanh Ward, 1 District, Ho Chi Minh City, Viet Nam
Phone: +84-283-821-5191

Ha Noi Service Center

Group 15 and No. 4, Alley 63, Truong Chinh Street, Phuong Liet Ward, Thanh Xuan District, Hanoi City, Viet Nam
Phone: +84-243-202-2585

THAILAND

Makita Manufacturing (Thailand) Co., Ltd.

219/1 Moo 6, Tambol Bowin, Amphur Sriracha, Chonburi, 20230
Phone: +66-3300-4750
Fax: +66-3300-4747

MALAYSIA

Makita Power Tools (Malaysia) Sdn. Bhd.

Head Office
Lot 824, Jalan Subang 5, Subang Industrial Area, 47500 Subang Jaya, Selangor, Malaysia
Phone: +60-(0)3-8023-0824
Fax: +60-(0)3-8022-1448

Johor(Johor Bahru) Service Center

No. 12 & 14, Jalan Rosmerah 2/9, Taman Johor Jaya, 81100 Johor Bahru, Johor
Phone: +60-(0)7-364-9406
Fax: +60-(0)7-364-9407

Sarawak(Kuching) Service Center

Lot 1227, Lorong Demak Indah 2A, Demak Laut Industrial Area, Phase 2A, 93050 Kuching Sarawak, Malaysia.
Phone: +60-(0)82-496-800
Fax: +60(0)82-496-900

Sabah(Kota Kinabalu) Service Center

Lot 19, Jalan Buah Duku, Kolombong Light Industrial Estate, Off Kolombong, Kolombong Zone 1, 88450 Inanam, Kota Kinabalu, Sabah
Phone: +60-(0)88-388-278
Fax: +60-(0)88-388 279

AMERICAS

UNITED STATES

Makita U.S.A. Inc.

Corporate office
14930 Northam Street, La Mirada, CA 90638-5753, USA
Phone: +1-714-522-8088
Fax: +1-714-522-8133
www.makitatools.com

Western regional (Los Angeles) office

14930 Northam Street, La Mirada, CA 90638-5753
Phone: +1-714-522-8088
Fax: +1-714-297-1544

Western regional (Reno) office

10200 Military Rd, Reno, NV, 89506
Phone: +1-775-437-9362

Eastern regional (Atlanta) office

4200 Falcon Parkway Flowery Branch, GA 30542
Phone: +1-770-476-8911
Fax: 866-521-3541 Free Dial USA only

Southern regional (Dallas) office

910 E. Pleasant Run Road, Wilmer, TX 75172
Phone: +1-972-441-8099
Fax: +1-855-231-0468

Factory service centers

Atlanta, Chicago, Dallas, Denver, Los Angeles, New Jersey, Reno

Makita Corporation of America

2650 Buford Highway, Buford, GA 30518-6045
Phone: +1-770-932-2901
Fax: +1-770-932-2905

Makita Latin America Inc.

Head office
9221 West 44th Ave. Suite 900, Hialeah, FL 33018
Phone: +1-305-882-0522
Fax: +1-305-882-0484
www.makitalatinamerica.com

Panama Branch

Local Comercial No.4, Albrook Office Center, calle Diego Dominguez, Albrook, Panama City, Panama
Phone: +507-315-0305
Fax: +507-315-0651

CANADA

Makita Canada Inc.

Head office
1950 Forbes Street, Whitby, ON L1N 7B7
Phone: +1-905-571-2200
Fax: +1-905-433-4779
www.makita.ca

Western regional office

11771 Hammersmith Way, Richmond, BC V7A 5H6
Phone: +1-604-272-3104
Fax: +1-604-272-5416

Factory service centers

Dartmouth(Halifax), Edmonton, Les Saules(Quebec City), Mississauga(Toronto), Richmond(Vancouver), Saskatoon, St. Leonard(Montreal), Whitby, Winnipeg

MEXICO

Makita México, S.A. de C.V.

Head office
Camino Viejo A San Lorenzo Tepaltitlan (Jose Marti) No.227 Col. Tlacopa, Toluca, Estado De Mexico, C.P. 50010
Phone: +52-722-385-8800 / 237-3293
www.makita.com.mx

Mexico city factory service center

Norte 35 #780-C Col. Industrial Vallejo, Del. Azcapotzalco Mexico, D.F. Mexico C.P. 02300
Phone: +52-55-5567-3387 / 5368-2937

Guadalajara factory service center

AV.Sierra Mazamitla #5864 Col.Pinar De La Calma Zapopan, Jalisco C.P. 45080
Phone: +52-33-3632-8032 / 3632-8057

Monterrey factory service center

Avenida Pablo Livas #4207 Colonia Guadalupe victoria, Municipio Guadalupe nuevo León, C.P.67180
Phone: +52-81-8372-4205 / 8372-4193

BRAZIL

Makita do Brasil Ferramentas Elétricas Ltda.

Head office & plant (MBRP)
Rodovia BR 376, Km 506,1 - (pista norte) Bairro Colônia Dona Luíza, CEP 84043-450 - Ponta Grossa, PR
Phone: +55-(0)42-3302-2100
www.makita.com.br

São Paulo sales office (MBR)

Rua Makita Brasil, 200 -Bairro Cooperativa - São Bernardo do Campo - SP CEP 09852-080
Phone: +55-(0)11-4392-2411 / 2199-2500

Bahia sales branch

Rua Itagi, 491- Bairro Pitangueiras - Lauro de Freitas, BA CEP: 42701-370
Phone: +55-(0)71-3252-0154

Rio de Janeiro service center

Av. Das Américas, 2250 - Loja J/K - Barra da Tijuca - Rio de Janeiro, RJ CEP:22640-101
Phone: +55-(0)21-3151-7933

Recife service center

Av. Marechal Mascarenhas de Moraes, 630, Bairro Imbiribeira, Recife, PE CEP 51170-000
Phone: +55-(0)81-3428-0210

Belo Horizonte service center

Rua Juiz de Fora, 95 - Bairro Barro Preto, Belo Horizonte, MG CEP 30180-060
Phone: +55-(0)31-2531-2017

Pará Sales Branch

Rodovia BR 316, Km 04 Loja 04-Bairro Rodovia Lindas,Ananindeua / PA CEP 67020-000
Phone: +55-(0)91-3237-7186

Porto Alegre service center

Av. Sertorio , 5539 - JD. Lindoia - Porto Alegre - RS CEP: 91050-371
Phone: +55-(0)51-3344-1464

Guaxupé service center

Av. Paulo Ribeiro do Valê, 1539 - Japy, Guaxupe - MG, CEP 37800-000
Phone: +55-(0)35-3551-2825

ARGENTINA

Makita Herramientas Eléctricas de Argentina S.A.

LISANDRO DE LA TORRE 1246, PARQUE INDUSTRIAL PILARICA, FATIMA, PILAR PROVINCIA DE BUENOS AIRES, CP1633
Phone: +54 (230)444-1100
Fax: +54 (230)444-1105
www.makita.com.ar

CHILE

Makita Chile Comercial Limitada

Head Office
AV.EL PARQUE 1307,PARQUE 5,MODULO 12, SECTOR ENEA PONIENTE PUDAHUEL, SANTIAGO,CHILE CP90031244
Phone: +56-2-2540-0400
www.makita.cl

Temuco factory service center

Av. Pedro de Valdivia #0524 , Local 14, Temuco
Phone: +56-2-2540-0460

Antofagasta factory service center

Pedro Aguirre Cerda 6259, local 3, Antofagasta
Phone: +56-2-2540-0470

Copiapó factory service center

Panamericana Norte 185, Bodega 10 Edificio 3, Ciudad de Copiapó, Región de Atacama

PERU

Makita Peru S.A.

Panamericana Sur - Km. 29, Distrito de Lurin, Provincia de Lima Centro de Operaciones "MEGACENTRO LURIN" Locales B1, B23, B24
Phone: +51-(1)-713-1212
www.makita.pe

Bolivia Branch

Av. Japón Nro. 3340 (3er. Anillo externo) entre Av. Alemana y Mutualista
Phone: +59-(1)-3347-1147
www.makita.bo

COLOMBIA

MAKITA COLOMBIA S.A.S

Head Office
Bodega 3 Lote 123, Centro Empresarial Celta Trade Park, Kilometro 7 Autopista Bogotá-Medellin Funza, Cundinamarca, Colombia
Phone: +57-601-742-9245
www.makita.com.co

Paloquemao factory service center

Carrera 22#18-63, Bogota, Cundinamarca, Colombia
Phone: +57-601-742-9245

UNITED KINGDOM**Makita (U.K.) Ltd.****Head office**

Michigan Drive, Tongwell, Milton Keynes, Bucks MK15 8JD
Phone: +44-(0)1908-211678
Fax: +44-(0)1908-211400
www.makitauk.com

Wigan Warehouse

Challenge Way, Martland Park, Wigan, WN5 0LD

Phone: +44-(0)1908-211678
Fax: +44-(0)1908-211400

Scotland factory service center

Unit 4A, Albion Trading Estate, 750 South Street, Glasgow, G14 0SY
Phone: +44-(0)141-9545861

London factory service center

Unit 5 Vector Park, Forest Road, Feltham, Middlesex, TW13 7EJ
Phone: +44-(0)20-88900586

Makita Manufacturing Europe Ltd.

Hortonwood 7, Telford, Shropshire TF1 7YX

Phone: +44-(0)1952-677688
Fax: +44-(0)1952-677678

FRANCE**Makita France SAS****Head office**

37, avenue Graham Bell, ZAC Léonard de Vinci, Bussy Saint-Georges, 77607 Marne-la-Vallée Cedex 3
Phone: +33-(0)1-6094-6400
Fax: +33-(0)1-6094-6380
www.makita.fr

Nantes office

Le Pan Loup, 44220 Couéron
Phone: +33-(0)2-5177-8977
Fax: +33-(0)2-4063-8376

Bordeaux office

137, Rue de la Croix-de-Monjous, 33170 Gradignan
Phone: +33-(0)5-5796-5270
Fax: +33-(0)5-5796-5275

Nord office

Village d'Entreprises, 51, Rue Trémière, 59650 Villeneuve d'Ascq
Phone: +33-(0)3-2059-7020
Fax: +33-(0)3-2047-2220

Lyon office

29 rue Antoine Condorcet, 38090 Villefontaine
Phone: +33-(0)7-8563-8049
Fax: +33-(0)1-60-94-63-86

Toulouse office

15, Rue de Boudeville, Z.I. de Thibaud, 31104 Toulouse
Phone: +33-(0)5-6143-2200
Fax: +33-(0)5-6143-2201

SPAIN**Makita, S.A.****Head office**

Calle Cerceda, nº 28 28052 Vicálvaro (Madrid)
Phone: +34-91-671-1262
Fax: +34-91-671-8293
www.makita.es

Barcelona Office

Bio Edificio Gonsi Sócrates Calle Antonio Machado nº 65 08840 Viladecans (Barcelona)
Phone: +34-935-669-124

PORTUGAL**Makita - Ferramentas Electricas, Sociedade Unipessoal, Lda.****portugal sales division**

Centro empresarial de Alverca, Vale das Ervas, Armazém C2 2615-187 Alverca do Ribatejo
Phone: +351-219-936-750
Fax: +351-219-574-982
www.makita.pt

ITALY**Makita S.p.A.**

Via Don Luigi Sturzo 56/58, Arluno, 20004, Milano, Italy
Phone: +39-0331-524111
Fax: +39-0331-420285
www.makita.it

GREECE**Makita Hellas S.A.**

Tatouiou 34, Acharnes, ATTIKI PC13677
Phone: +30-210-8071241
Fax: +30-210-8072245
www.makita.gr

FINLAND**Makita Oy**

Tuotantotie 21, 04300 Tuusula, Finland
Phone: +358-(09)8578-830
Fax: +358-(0)9-857-88211
www.makita.fi

FSC

Krouvintie 5 90400 Oulu, Finland
Phone: +358 (0)8-237-48930

ESTONIA**Makita Oy Estonian Branch****Head office**

Kaupmehe tn 5, Laagri alevik, 76401 Saue vald, Estonia
Phone: +372-6-510-380
Fax: +372-6-510-399
www.makita.ee

LATVIA**Makita OY Latvian Branch****Latvian factory service center**

Vienības gatve 153/1, Mārupe Mārupes nov., LV-2167, LATVIA
Phone: +371 6796 9564
Fax: +371 6796 9564
www.makita.lv

LITHUANIA**Makita OY Lithuanian Branch****Lithuanian factory service center**

L. Zamenhofo Str. 3, Vilnius, LT-06332, LITHUANIA
Phone: +370 5 236 0400
Fax: +370 5 236 0407
www.makita.lt

SWEDEN**Makita Sweden**

Bergkällavägen 36A 192 79 SOLLENTUNA SWEDEN
Phone: +46-8-505-819-00
Fax: +46-8-505-819-69
www.makita.se

NORWAY**Makita Norway**

Løxaveien 15 1351 Rud Norway
Phone: +47-67 17 69 00
Fax: +47 67 17 69 01
www.makita.no

THE NETHERLANDS**Makita Nederland B.V.****Head office**

Park Forum 1101 5657HK Eindhoven
Phone: +31-(0)40-206-4040
Fax: +31-(0)40-206-4096
www.makita.nl

Utrecht Service Center

Straat van Gibraltar 6, 3446CM Woerden
Phone: +31-(0)40-206-4040
Fax: +31-(0)40-206-4096

BELGIUM**S.A. Makita N.V.**

Jan-Baptist Vinkstraat 2 3070 Kortenberg
Phone: +32-(0)2-257-1840
Fax: +32-(0)2-253-0101
www.makita.be

Boom warehouse

Industrieweg 1C 2850 Boom

Charleroi Service Center

Avenue de Heppignies 6 6220 Fleurus

GERMANY**Makita Werkzeug GmbH****Head office**

Makita Platz 1,40885 Ratingen
Phone: +49 (0)2102 1004-0
www.makita.de www.dolmar.de/

Makita Service Center Hamburg

Jenfelder Strasse 51, 22045 Hamburg
Phone: +49 (0) 2102 1004-456

Makita Service Center Berlin

Gartenfelder Strasse 29 - 37 Gebäude 44, 13599 Berlin
Phone: +49 (0)30 339 756 50

Makita Service Center Lehrte

Everner Strasse 30, 31275 Lehrte
Phone: +49 (0)5132 5042153
www.makita.de

Makita Service-Center Groß-Gerau

Hans-Böckler-Str. 22 64521 Groß-Gerau
Phone: +49 (0)6152 9788500
www.makita.de

Makita Logistics Center South Germany

Baumschulenstrasse 1B, 93083 Obertraubling
Phone: +49 (0)2102 1004-410
www.makita.de

Makita Service Center München

Martin-Kollar-Straße 4, 81829 München EG VE 04
Phone: +49 (0)89 904 238 500
www.makita.de

Makita Engineering Germany GmbH

Jenfelder Strasse 38, 22045 Hamburg
Phone: +49-(0)40-66986-0
Fax: +49-(0)40-66986-352
www.makita-engineering.de

DENMARK**Makita Elværktøj Danmark****Denmark office**

Vegavej 17, 8700 Horsens, Kingdom of Denmark
Phone: +45-76-254400
www.makita.dk

SWITZERLAND**Makita SA**

Chemin du Vuasset 7 CH-1028 Preverenges
Phone: +41-(0)21-811-5656
Fax: +41-(0)21-811-5678
www.makita.ch

AUSTRIA**Makita Werkzeug Gesellschaft m.b.H.**

Airportstraße 4 A-2401 Fischamend
Phone: +43-(0)2232-77700-0
Fax: +43-(0)2232-77700-13
www.makita.at

SLOVENIA**MAKITA.d.o.o.**

Brnčičeva 17, SI-1231 Ljubljana-Črnuče, Slovenia
Phone: +386(0) 590 83 600
Fax: +386(0) 590 83 601
www.makita-see.com

CROATIA**Croatia factory service center**

Kreše Golika 3A, HR- 10000 Zagreb
Phone: +385 1 2078 252
www.makita-see.com

UKRAINE**Makita Ukraine LLC**

61 Oleha Onikiyenko Str., Brovary, Kyiv region 07400, Ukraine
Phone: +38 (044) 494-23-70
+38 (044) 494-23-71
Fax: +38 (044) 494-23-73
www.makita.ua

Dnipro FSC

5 Kursanta Ckorobogatka Str., Dnipro, Dnipropetrovsk region 49124, Ukraine
Phone: +380 (44) 492-27-73

POLAND**Makita Sp. z o.o.****Head office**

ul. Bestwińska 103 43-346 Bielsko - Biała
Phone: +48-(0)33-484-0200
Fax: +48-(0)33-818-4059
www.makita.pl

Warsaw branch

Moszna-Parcela 29 05-840 Brwinów
Phone: +48-(0)22-177-7300

CZECH REPUBLIC**Makita, spol. s r.o.**

Tovární 941/1a Brno - Chrllice, 643 00 Czech Republic (CZ)
Phone: +42-(0)5-432-16944
Fax: +42-(0)5-432-16946
www.makita.cz

Prague Service Center

K Bílému Vrchu 3040/16, 193 00 Prague 9
Phone: +42-(0)2-991-40585

SLOVAKIA**Makita s.r.o.**

Priemyselná 26 974 01 Banská Bystrica
Phone: +421-(0)48-4161-772
Fax: +421-(0)48-4161-769
www.makita.sk

HUNGARY**Makita Elektromos Kiszéptékesítő Kft.**

8000 Székesfehérvár, Kukorica u. 7.
Phone: +36-22-507-472
Fax: +36-22-507-484
www.makita.hu

MIDDLE EAST/ AFRICA

ROMANIA

Makita Romania S.R.L.

Strada Garii Nr.6, Loc.Branesti, jud.Ilfov,
Romania
Phone: +40 21 569 80 61
+40 21 569 80 62
Fax: +40 21 569 80 59
www.makita.ro

Cluj-Napoca Factory Service Center

Str. Bld. Muncii, Nr. 68, 400641
Cluj, Romania
Phone: +40 21 569 80 61

Iasi Factory Service Center

Boulevard Poitiers No. 2, 700671
Iasi, Romania
Phone: +40 21 569 80 61

SC Makita EU SRL

Str.I.C. Bratianu, nr.164, Comuna Branesti,
jud. ILFOV, ROMANIA 077030
Phone: +40-21-310-7675
Fax: +40-21- 200-0219

BULGARIA

Makita Bulgaria EOOD

Okolovrasten Pat (circle road), No.373,
Sofia 1186, Bulgaria
Phone: +359-2-921-0551
Fax: +359-2-921-0550
www.makita.bg

GEORGIA

LTD «Makita Georgia»

64, D. Guramishvili avenue, 0141, Tbilisi,
Georgia
Phone: +995 032 243 06 43

KAZAKHSTAN

Makita Kazakhstan LLP

Zakarpatskaya str., 45, 050039, Almaty,
Kazakhstan
Phone: +7 727 355 8866

UNITED ARAB EMIRATES

Makita Gulf FZE

P.O. Box 17133,
Jebel Ali Free Zone, Dubai, UAE
Phone: +971-(0)4-8860-804
Fax: +971-(0)4-8860-805
www.makita.ae

TANZANIA

MAKITA AFRICA LIMITED

P.O. Box 20998,
2nd Floor, Staywell Office Building, Haile
Selassie Road, Msasani Peninsula, Dar es
Salaam, Tanzania
Phone: +255 22 2602870

MOROCCO

MAKITA MOROCCO SARLAU

Rte Zenata Lot Marhaba Show Room N5
Espace Commercial Asteria Amal 5 A S,
20250 Casablanca, Morocco
Phone: +212 522 355696
Fax: + 212 522 344808

OCEANIA

AUSTRALIA

Makita (Australia) Pty. Ltd.

Head office

2 Litton Close Pemulwuy, NSW. 2145
Phone: +61 1300 361 690
Fax: +61 1300 361 770
www.makita.com.au

Hobart office

32a Chapel Street Glenorchy, TAS 7010
Phone: +61 1300 361 690
Fax: +61 1300 361 770

Perth office

374A Kenwick Rd Maddington WA 6109
Phone: +61 1300 361 690
Fax: +61 1300 361 770

Factory Service Center

Sydney, Melbourne, Brisbane, Perth,
Hobart, Townsville, Adelaide

NEW ZEALAND

Makita (New Zealand) Limited

Head office

46 Westpoint Drive, Hobsonville,
Auckland 0618
Phone: +64-(0)9-479-8251
Fax: +64-(0)9-479-8259
www.makita.co.nz

Christchurch Office

27 Hannover Place, Rolleston,
Christchurch 7614
Phone: +64-(0)3-930-0500

Factory Service Center

Auckland, Christchurch, Wellington

Product Catalogue



Makita Corporation
3-11-8 Sumiyoshi-cho, Anjo, Aichi 446-8502 Japan
www.makita.com



**official YouTube
channel**



www.makita.com